

 **Kawasaki**

K3VL

**Axial Piston Pumps for
Open Circuits in Mobile, Industrial
and Marine Applications**



Contents

1. General Description	IFC
2. Specifications	1
3. Model Coding	2
4. Functional Description of Regulators	4
5. Performance Curves	8
K3VL45	8
K3VL60	9
K3VL80	10
K3VL112	11
K3VL140	12
K3VL200	13
6. Mounting Precautions	14
7. Filtration	15
8. Hydraulic Fluid Requirements	15
9. Initial Start-up	15
10. Drive Shaft Coupling	15
11. Installation Drawings	16
K3VL45/60	16
K3VL80	18
K3VL112/140	20
K3VL200	23
12. Response Time	24
13. Through Drives	25
14. Pump Controls	28
15. Integral Unloading Valve, Proportional Unloading Valve, Electronic Displacement Control	29
16. KC-B10-11 Proportional Amplifier	IBC

1.0 General Description

K3VL series swash-plate type axial piston pumps are designed to satisfy medium to heavy-duty open circuit applications in the mobile, industrial, marine and other industries. The rotation groups are based on the proven design of the K3V and K3VG pumps. K3VL pumps are available in nominal displacements ranging from 2.75 to 12.20 in³/rev (45 to 200 cc/rev) with various pressure, flow, and combination control options.

Key features of K3VL pumps include:

- Continuous pressure rating of 4600 psi (320 bar), 3625 psi (250 bar) for K3VL60.
- High overall efficiency (> 90% peak)
- Exceptional self priming capabilities.
- American (SAE) or European (ISO) mounting and shaft
- Excellent reliability and very long service life.
- High power to weight ratio.
- Numerous control options.
- Variety of optional through drives.
- Quick control response.
- Low pulsation and noise levels.
- Integral unloading valve or proportional pressure relief valve available

2.0 Specifications

Pump Model		K3VL45	K3VL60	K3VL80	K3VL112	K3VL140	K3VL200
Displacement - in ³ /rev (cc/rev)		2.75 (45)	3.66 (60)	4.88 (80)	6.83 (112)	8.54 (140)	12.20 (200)
Pressure Rating - psi (bar)	Rated	4600 (320)	3625 (250)	4600 (320)	4600 (320)	4600 (320)	4600 (320)
	^{*1} Peak	5075 (350)	4060 (280)	5075 (350)	5075 (350)	5075 (350)	5075 (350)
Speed Rating (rpm at Max. Displacement)	^{*2} Self Prime	2700	2400	2400	2200	2200	1900
	^{*3} Maximum	3250	3000	3000	2700	2500	2200
Minimum Operating Speed - rpm		600	600	600	600	600	600
Maximum Allowable Case Drain Pressure - psi (bar)	Continuous	30 (2)					
	Peak	85 (6)					
Pump Case Prefill Capacity - Gallons (Liters)		0.16 (0.60)	0.16 (0.60)	0.21 (0.80)	0.37 (1.40)	0.37 (1.40)	.78 (3)
Weight - lb (kg)		55 (25)	55 (25)	77 (35)	143 (65)	143 (65)	220 (100)
Temperature Range -°F (°C)		-4° to 203° (-20° to 95°)					
^{*4} Viscosity Range - SUS (cSt)		55 to 4650 (10 to 1000)					
Maximum Contamination Level		20/18/15 ISO/DIS 4406 (Class 9)					
^{*5} Standard Mounting Flange and Shaft	Mounting	2-Bolt SAE B	2-Bolt SAE B	2-Bolt SAE C	4-Bolt SAE D	4-Bolt SAE D	4-Bolt SAE E
	Shaft	SAE B-B Spline or Key	SAE B-B Spline or Key	SAE C Spline or Key	SAE D Spline or Key	SAE D Spline or Key	SAE D Spline or Key
Optional Mounting Flange and Shaft	Mounting	-	-	-	2-Bolt SAE C	2-Bolt SAE C	-
	Shaft	SAE B Spline	SAE B Spline	-	SAE C or C-C Spline or Key	SAE C or C-C Spline or Key	-
Input Shaft Torque Rating		Refer to Table 2.1					
Through Drive Torque Rating - lb _f -ft (Nm)	SAE A	45 (61)	45 (61)	45 (61)	45 (61)	45 (61)	45 (61)
	SAE B	150 (203)	150 (203)	150 (203)	150 (203)	150 (203)	150 (203)
	SAE B-B	166 (225) ^{*5}	166 (225) ^{*5}	166 (225)	166 (225)	166 (225)	166 (225)
	SAE C	-	-	295 (400)	295 (400)	295 (400)	295 (400)
	SAE C-C	-	-	-	412 (559) ^{*6}	412 (559) ^{*6}	412 (559) ^{*6}
	SAE D	-	-	-	516 (699) ^{*6}	516 (699) ^{*6}	516 (699) ^{*6}
	SAE E	-	-	-	-	-	516 (699) ^{*6,7}

*1 Maximum allowable safety relief valve setting.

*2 Steady state inlet pressure should be greater than or equal to 0 psi (0 bar) gauge.

*3 Steady state inlet pressure should be greater than or equal to 4.5 psi (0.3 bar) gauge. However the maximum charge pressure should not exceed 50 psi (3.5 bar).

*4 At viscosities from 930 to 4650 SUS (200 to 1000 cSt), warm up at no load is required.

*5 ISO mounting and shaft also available. Contact Kawasaki for further instructions.

*6 Through drive torque rating exceeds torque rating of the optional input shaft.

*7 SAE E through drive uses the SAE D shaft

Table 2.1 Input Shaft Torque Rating

Shaft Type	SAE B	SAE B-B	SAE C	SAE C-C	SAE D
Rated Total Input Torque - lbf-ft (Nm)	114 ^{*1} (155) ^{*1}	166 (225)	295 (400) ^{*1}	413 (560) ^{*1}	516 (699)
^{*2} Maximum Total Input Torque - lbf-ft (Nm)	126 ^{*1} (171) ^{*1}	182 (248)	378 (514) ^{*1}	610 (827) ^{*1}	1014 (1379)

^{*1} Displacement or maximum pressure must be reduced to operate within the input shaft torque rating when used as an optional shaft. See chart below.

^{*2} Shaft surface will have finite life due to wear unless adequate lubrication is provided.

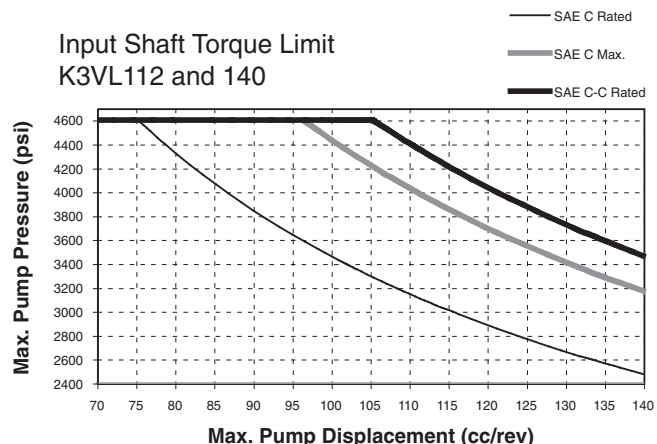
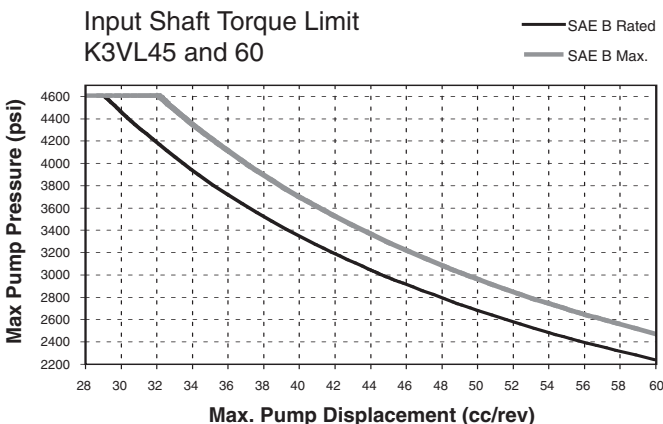

3.0 Model Coding

K3VL 80 /B - 1 0 R K S - L0 () /1 - H1
[1] [2] [3] [4] [5] [6] [7] [8] [9] [10] [11] [12] [13]

[1]	K3VL Series Variable Displacement, Axial Piston, Open Loop Pump		
[2]	Maximum Displacement	45 60 80 112 140 200	45 cc/rev (2.75 in ³ /rev) 60 cc/rev (3.66 in ³ /rev) 80 cc/rev (4.88 in ³ /rev) 112 cc/rev (6.83 in ³ /rev) 140 cc/rev (8.54 in ³ /rev) 200 cc/rev (12.20 in ³ /rev)
[3]	Design Series	Series B	
[4]	Hydraulic Fluid	-	Mineral oil (Nitrile seals except Viton shaft seal)
[5]	Circuit Type	1	Open circuit
[6]	Through Drive	0 A B BB *1 C *2 CC *2 D *6 E R N S	Without through drive SAE A shaft coupling and mount SAE B shaft coupling and mount SAE BB shaft coupling and SAE B mount SAE C shaft coupling and mount SAE CC shaft coupling and SAE C mount SAE D shaft coupling and SAE D mount SAE D shaft coupling and SAE E mount Rear ports (No through drive) With through drive covered and sealed; no shaft coupling included Stock model; no steel cover or shaft coupling included
[7]	Direction of Rotation	R L	Clockwise Counterclockwise
[8]	Mounting and Shaft Type	K S M T C X W Y	SAE mounting flange with SAE straight key shaft SAE mounting flange with SAE spline shaft ISO mounting flange with ISO straight key shaft SAE B mounting flange with SAE B spline shaft (K3VL45 only) SAE C mounting flange with SAE C spline shaft (K3VL112 and 140 only) SAE C mounting flange with SAE C straight key shaft (K3VL112 and 140 only) SAE C mounting flange with SAE C-C spline shaft (K3VL112 and 140 only) SAE C mounting flange with SAE C-C straight key shaft (K3VL112 and 140 only)
[9]	Port Options	S M	SAE 4-bolt flange ports with UNC threads SAE 4-bolt flange ports with metric threads
[10]	Control Device	*3 L0 *3 L1 *3 LN *3 LM *3,5 LV *4 P0 *4 PN *3 PM *4,5 PV	Load sense & pressure cut-off Load sense & pressure cut-off (No bleed off for load sense line) With integral unloading valve (Normally closed) With integral unloading valve (Normally open) With integral proportional relief valve Pressure cut-off With integral unloading valve (Normally closed) With integral unloading valve (Normally open) With integral proportional relief valve

*1 Not available on K3VL45 and K3VL60

*2 Only available on K3VL112, K3VL140 and K3VL200

*3 Differential pressure is pre-set at the factory to 218 psi (15 bar)

*4 Cut-off pressure is pre-set at the factory to 4600 psi (320 bar)

*5 LV and PV options require amplifier; See Section 16: KC-B10-11 Amplifier

*6 Only available on K3VL200

4.0 Functional Description of Regulators

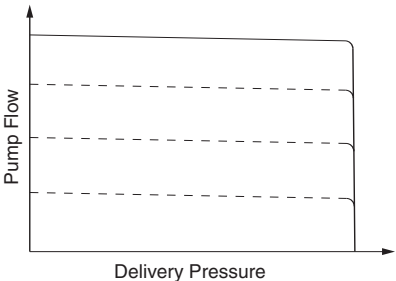
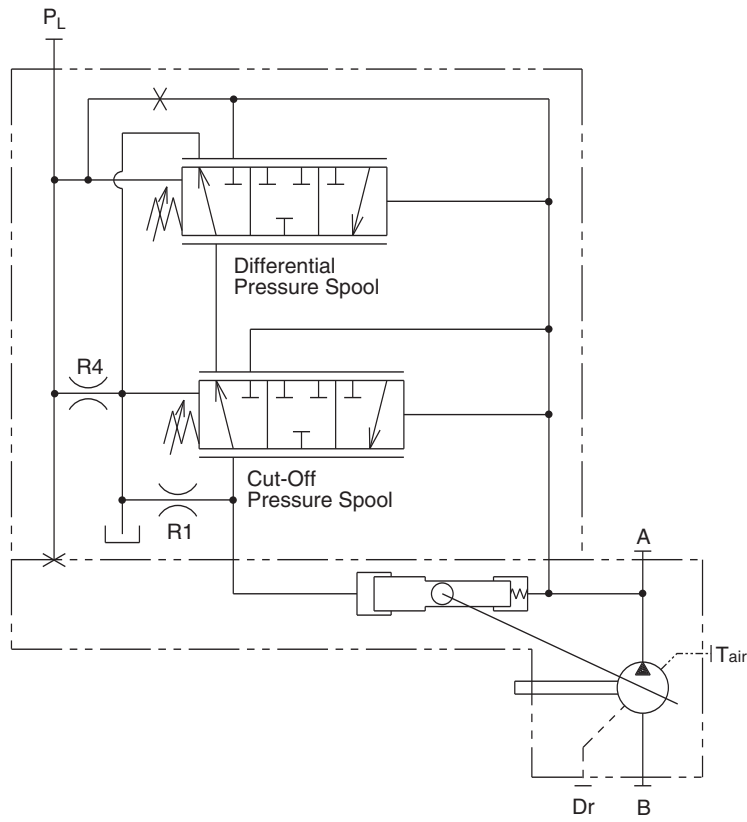
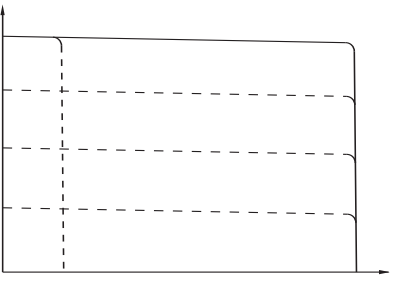
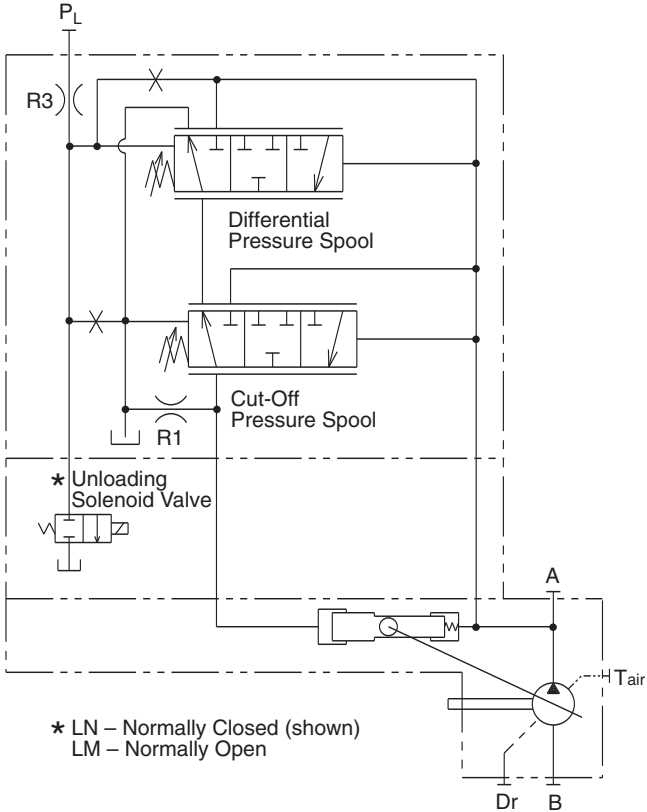
Regulator code	Hydraulic Circuit
<p>LO/L1 Load Sense and Pressure Cut-off</p> <p>Description: Pump displacement is controlled to match the flow requirement as a function of the system differential pressure (load pressure vs delivery pressure). In addition, there is a pressure cutoff function incorporated into the control.</p> <p>Differential Pressure: Standard Setting - 218 psi (15 bar) Adjustment Range - 145 psi (10 bar) ~ 300 psi (21 bar)</p> <p>Cut-off Pressure: Standard Setting - 4600 psi (320 bar) Adjustment Range - 300 psi (21 bar) ~ 4600 psi (320 bar)</p> <p>L1 Option: With the L1 option, the bleed off orifice (R4) is plugged. When this option is applied, there must be another bleed-off orifice in the external valving.</p> 	
<p>LN or LM Loadsense and Pressure Cut-off with Integrated Unloading Valve</p> <p>Description: An integrated unloading valve is sandwiched between the Load Sense regulator and pump to effectively de-stroke the swashplate when an electric signal is provided.</p> <p>Standby Pressure: The minimum standby pressure is approximately 200 psi (14 bar) at the minimum Differential Pressure setting.</p> 	 <p>* LN – Normally Closed (shown) * LM – Normally Open</p>

Warning: A safety relief valve should be installed in the hydraulic circuit at the pump outlet.

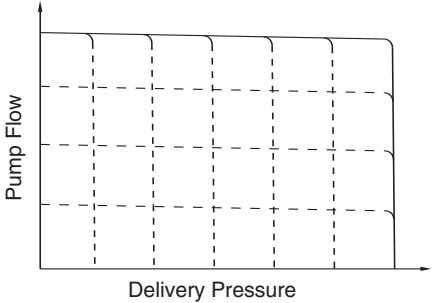
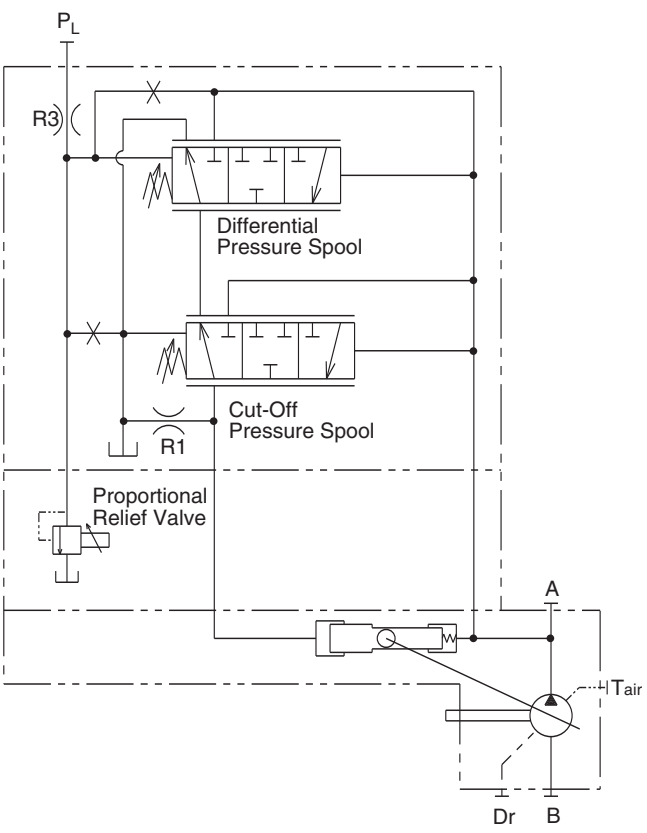
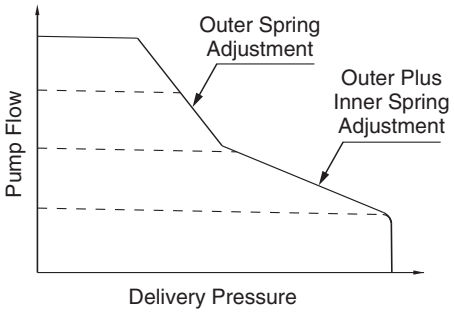
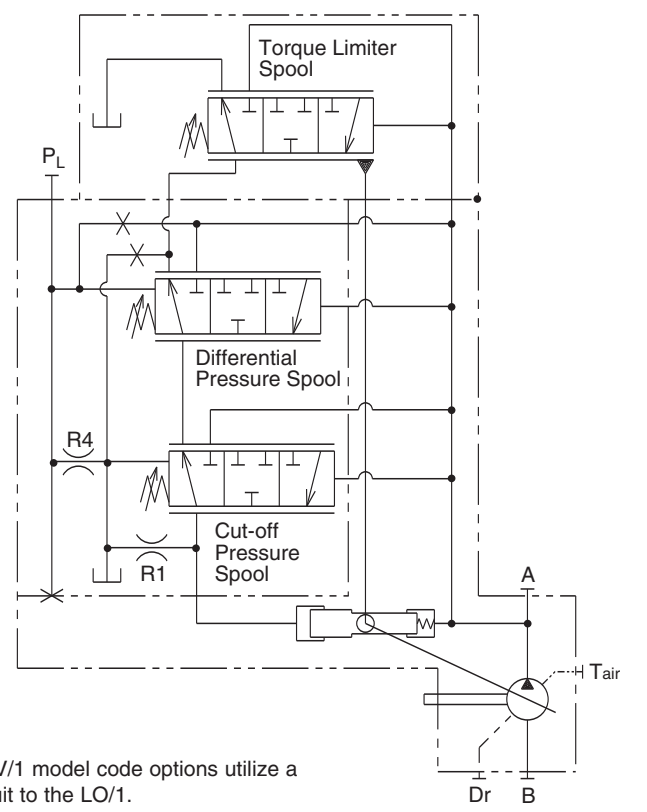
Regulator code	Hydraulic Circuit
<p>LV Load Sense and Pressure Cut-off with Integrated Proportional Relief Valve</p> <p>Description: An integrated proportional relief valve is sandwiched between the Load Sense regulator and pump to control the maximum pressure setting by varying an electric signal to the valve.</p> <p>Standby Pressure: The minimum standby pressure is approximately 200 psi (14 bar) at the minimum Differential Pressure setting.</p> <p>Amplifier: Separate amplifier is required for the LV control. See Section 16: KC-B10-11 Amplifier.</p> 	
<p>LO/1** Load Sense and Pressure Cut-off with Torque Limiting</p> <p>Description: LO/L1 control functions as previously noted. In response to a rise in delivery pressure the swashplate angle is decreased, restricting the input torque. This regulator prevents excessive torsional load on the prime mover and shafts.</p> <p>Torque limit control module includes two preloaded springs that oppose a spool force generated by system pressure. Swashplate position is fed back to the torque limit control via a feedback lever and sleeve mechanism. By turning the outer and inner spring adjustment screws, the appropriate input torque limit can be set.</p> 	 <p>LN/1 and LV/1 model code options utilize a similar circuit to the LO/1.</p>

Warning: A safety relief valve should be installed in the hydraulic circuit at the pump outlet.

4.0 Functional Description of Regulators (Continued)

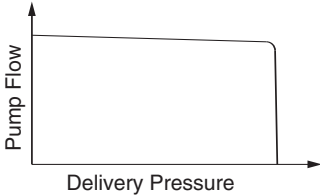
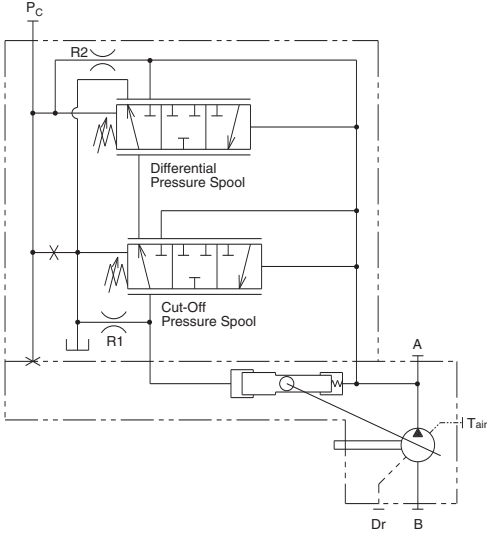
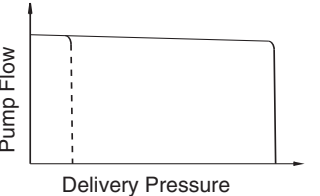
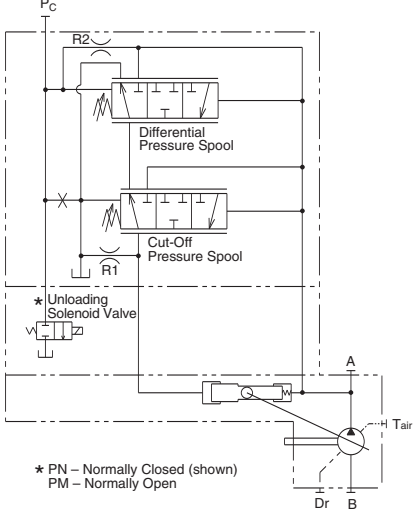
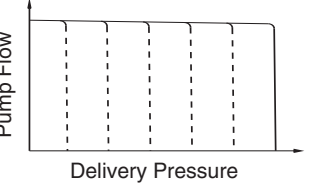
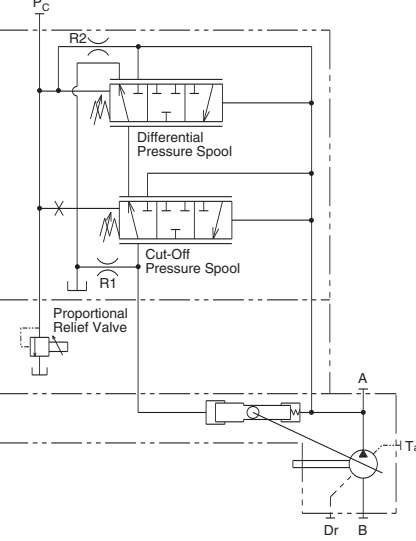
Regulator code	Hydraulic Circuit
<p>PO Pressure Cut-off</p> <p>Description: As system pressure rises to the cut-off setting, the swashplate de-strokes to prevent the system pressure from exceeding the cut-off setting.</p> <p>Differential Pressure: Standard Setting - 218 psi (15 bar) Adjustment Range - 145 psi (10 bar) ~ 300 psi (21 bar)</p> <p>Cut-off Pressure: Standard Setting - 4600 psi (320 bar) Adjustment Range - 300 psi (21 bar) ~ 4600 psi (320 bar)</p> <p>Remote Control: By connecting the Pc port to a remote pressure control, variable pump pressure control (or unloading) can be achieved.</p> 	
<p>PN or PM Pressure Cut-off with Integrated Unloading Valve</p> <p>Description: An integrated unloading valve is sandwiched between the Pressure Cut-off regulator and pump to effectively de-stroke the swashplate when an electric signal is provided.</p> <p>Standby Pressure: The minimum standby pressure is approximately 200 psi (14 bar) at the minimum Differential Pressure setting.</p> 	 <p>* PN – Normally Closed (shown) PM – Normally Open</p>
<p>PV Pressure Cut-off with Integrated Proportional Relief Valve</p> <p>Description: An integrated proportional relief valve is sandwiched between the Pressure Cut-off regulator and pump to control the maximum pressure setting by varying an electric signal to the valve.</p> <p>Standby Pressure: The minimum standby pressure is approximately 200 psi (14 bar) at the minimum Differential Pressure setting.</p> <p>Amplifier: Separate amplifier is required for the PV control. See Section 16: KC-B10-11 Amplifier.</p> 	

Warning: A safety relief valve should be installed in the hydraulic circuit at the pump outlet.

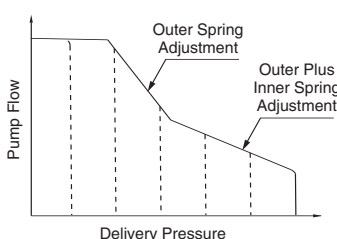
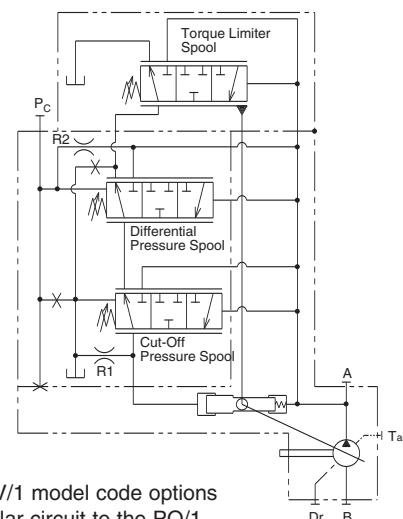
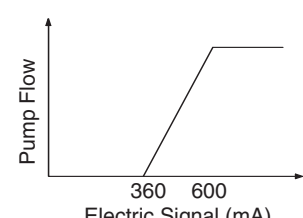
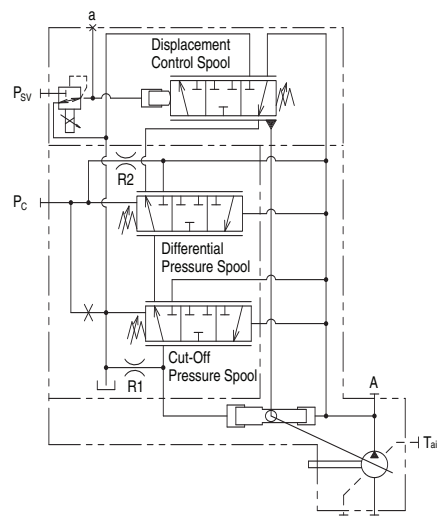
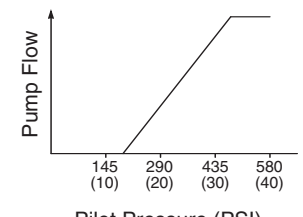
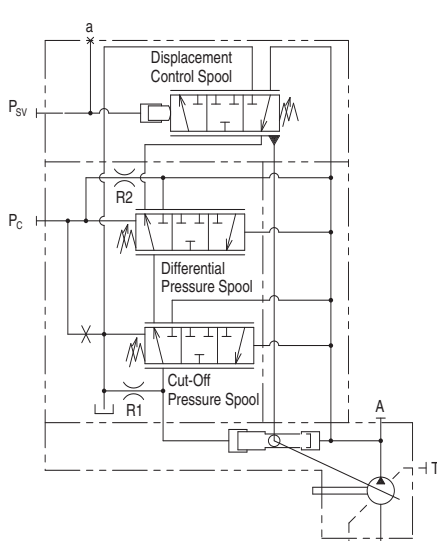
Regulator code	Hydraulic Circuit
<p>PO/1** Pressure Cut-off with Torque Limiting</p> <p>Description: PO control functions as previously noted. In response to a rise in delivery pressure the swashplate angle is decreased, restricting the input torque. This regulator prevents excessive torsional load on the prime mover and shafts.</p> <p>Torque limit control module includes two preloaded springs that oppose a spool force generated by system pressure. Swashplate position is fed back to the torque limit control via a feedback lever and sleeve mechanism. By turning the outer and inner spring adjustment screws, the appropriate input torque limit can be set.</p> <p>Remote Control: By connecting the Pc port to a remote pressure control, variable pump pressure control (or unloading) can be achieved.</p> 	 <p>PN/1 and PV/1 model code options utilize a similar circuit to the PO/1.</p>
<p>P0/1-E0 Electronic Displacement Control with Pressure Cut-off</p> <p>Description: P0 control functions as previously noted. A proportional pressure reducing valve (PPRV) is added to the regulator so the pump flow can be infinitely controlled within the range of the pump. An increase in electric signal to the PPRV will result in an increase in flow. A pilot pressure of 580 psi must be supplied to the PSV port.</p> <p>Amplifier: Separate amplifier is required for the E0 control. See Section 16: KC-B10-11 Amplifier. Recommended dither frequency 50–200Hz</p> 	
<p>PO/1-QO Hydraulic Pilot Displacement Control with Pressure Cut-off</p> <p>Description: P0 control functions as previously noted. By applying a varying hydraulic pilot pressure to the Psv port of the displacement controller, the pump flow can be infinitely controlled within the range of the pump. An increase in the hydraulic pilot signal results in an increase of output flow. Maximum output flow is achieved at 480 psi.</p> <p>Remote control: By connecting the Pc port to a remote pressure control, variable pump pressure control (or unloading) can be achieved.</p> 	

Warning: A safety relief valve should be installed in the hydraulic circuit at the pump outlet.

5.0 Performance Curves — K3VL45

Efficiency

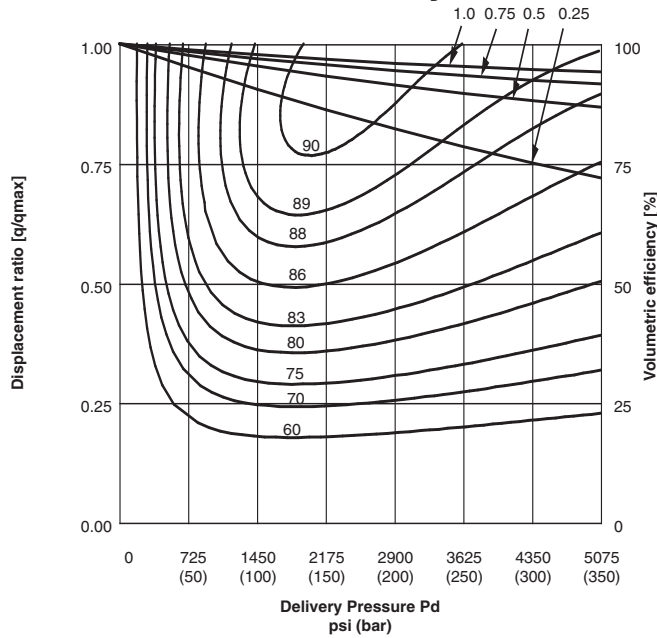

Self-priming Capability

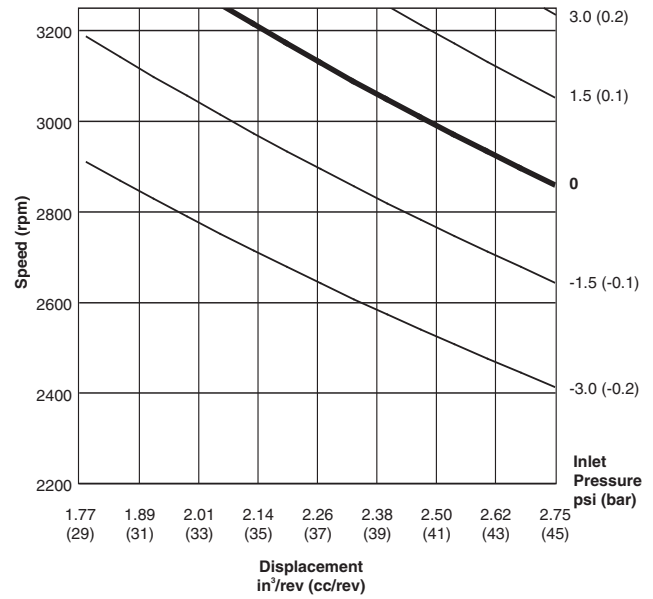

Bearing Life

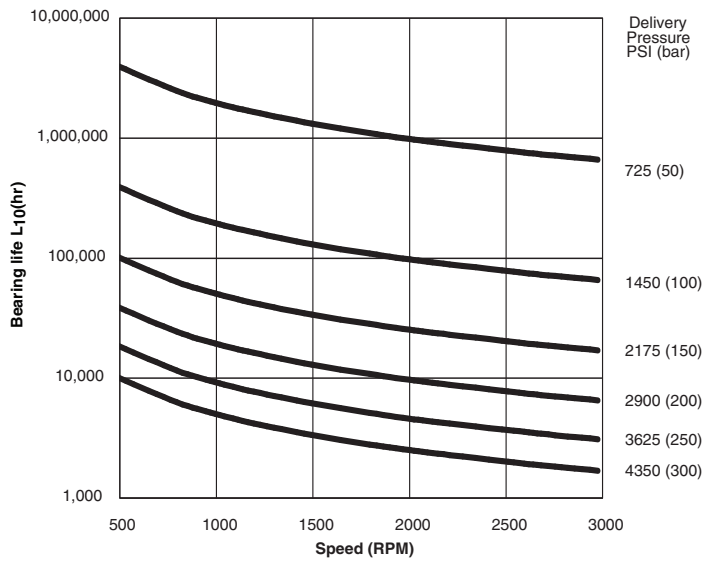

Noise Level

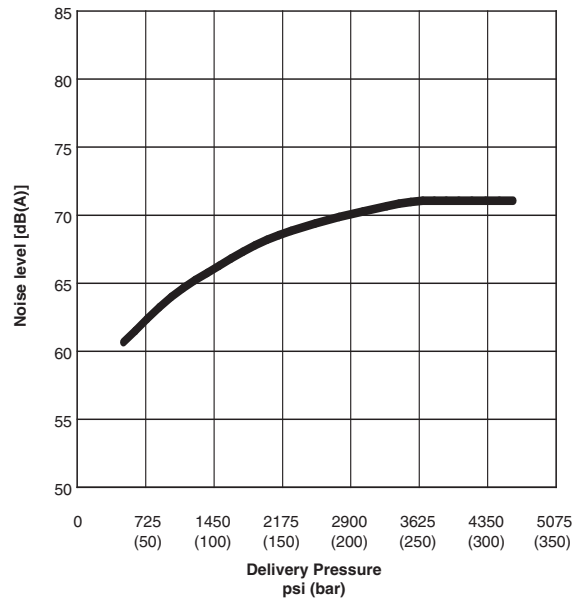

Performance Notes:

- All curves are based on an input speed of 1800 rpm, ISOVG46 hydraulic oil, 122°F (50°C) oil temperature, and 0 psi (0 bar) inlet condition, unless otherwise noted.
- L_{10} bearing life is defined as the period of time for 10% of an identical group of bearings operated under the same conditions to begin to fail as a result of rolling fatigue. Bearing life is further reduced by elevated temperatures, contamination, shaft radial loads, and lubricant breakdown. Consult Kawasaki for detailed bearing life analysis.
- Noise levels are measured in a semi-anechoic chamber in a manner similar to NFPA 13.9.70.12 and DIN 43635
- For application requirements not covered by the performance curves above, consult Kawasaki.

5.0 Performance Curves — K3VL60

Efficiency

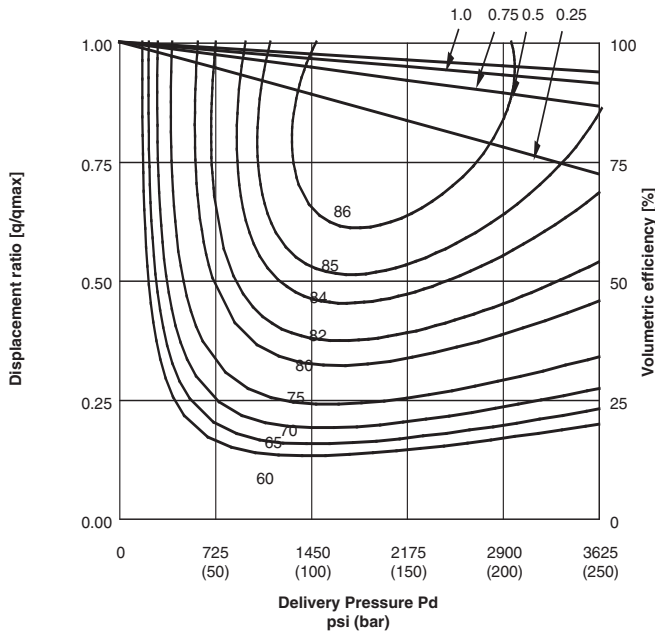

Self-priming Capability

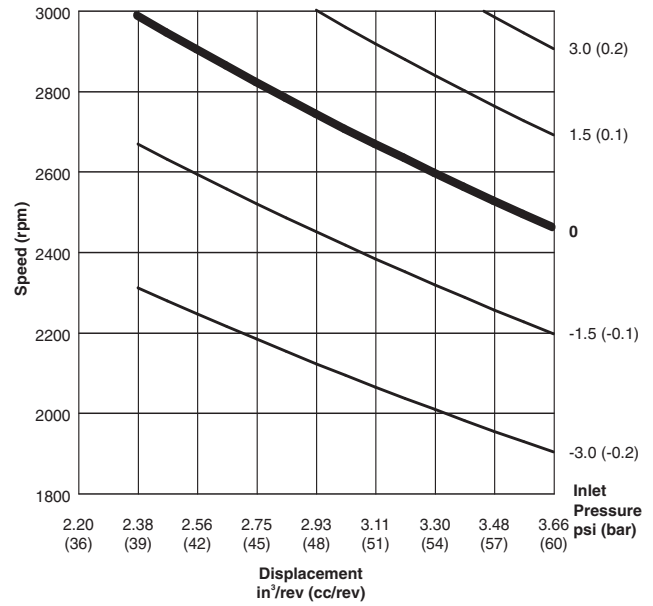

Bearing Life

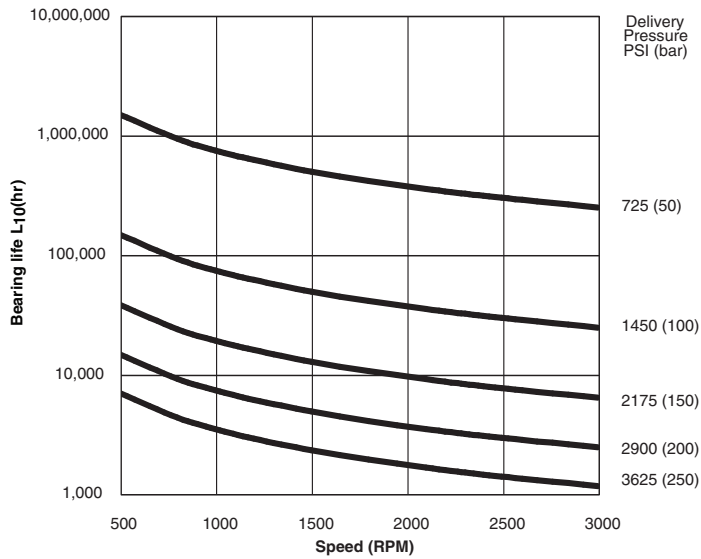

Noise Level

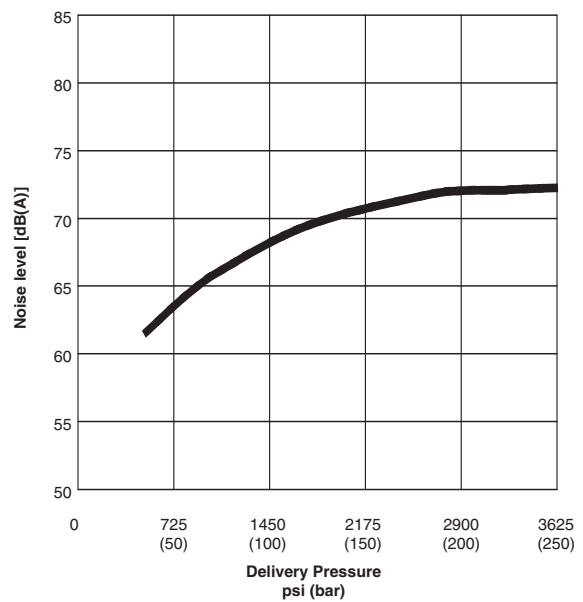

Performance Notes:

- All curves are based on an input speed of 1800 rpm, ISOVG46 hydraulic oil, 122°F (50°C) oil temperature, and 0 psi (0 bar) inlet condition, unless otherwise noted.
- L_{10} bearing life is defined as the period of time for 10% of an identical group of bearings operated under the same conditions to begin to fail as a result of rolling fatigue. Bearing life is further reduced by elevated temperatures, contamination, shaft radial loads, and lubricant breakdown. Consult Kawasaki for detailed bearing life analysis.
- Noise levels are measured in a semi-anechoic chamber in a manner similar to NFPA 13.9.70.12 and DIN 43635
- For application requirements not covered by the performance curves above, consult Kawasaki.

5.0 Performance Curves — K3VL80

Efficiency

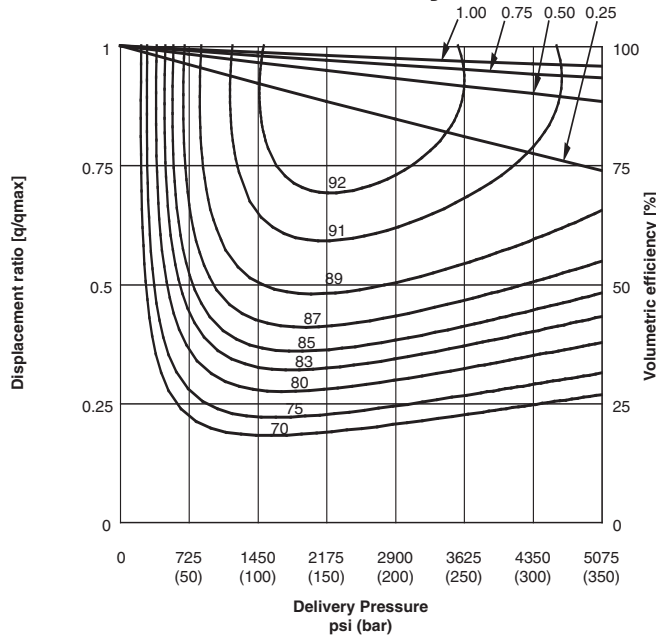

Self-priming Capability

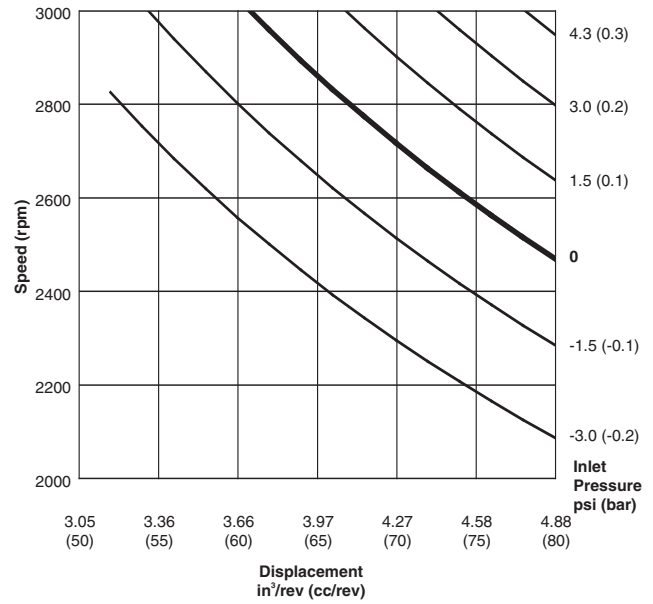

Bearing Life

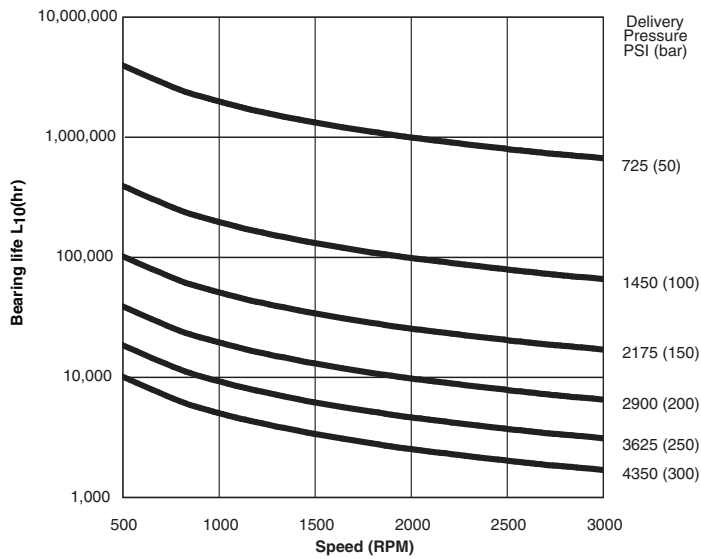

Noise Level

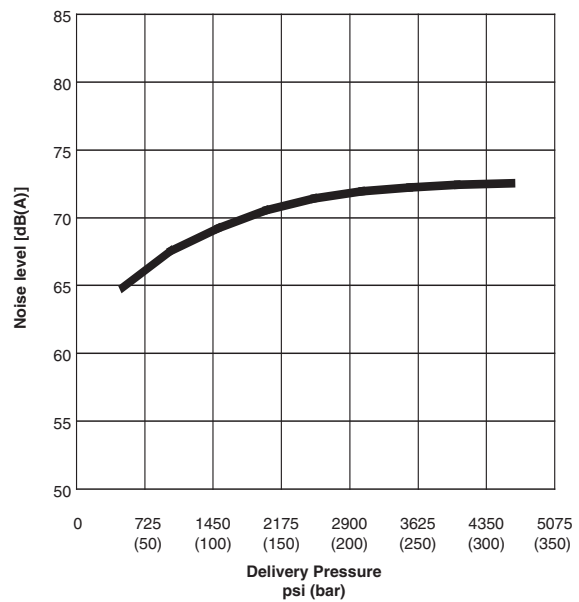

Performance Notes:

- All curves are based on an input speed of 1800 rpm, ISOVG46 hydraulic oil, 122°F (50°C) oil temperature, and 0 psi (0 bar) inlet condition, unless otherwise noted.
- L_{10} bearing life is defined as the period of time for 10% of an identical group of bearings operated under the same conditions to begin to fail as a result of rolling fatigue. Bearing life is further reduced by elevated temperatures, contamination, shaft radial loads, and lubricant breakdown. Consult Kawasaki for detailed bearing life analysis.
- Noise levels are measured in a semi-anechoic chamber in a manner similar to NFPA 13.9.70.12 and DIN 43635
- For application requirements not covered by the performance curves above, consult Kawasaki.

5.0 Performance Curves — K3VL112

Efficiency

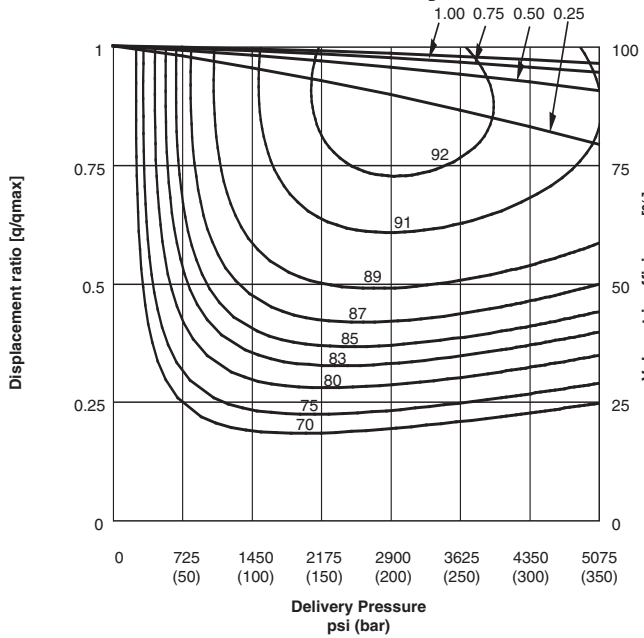

Self-priming Capability

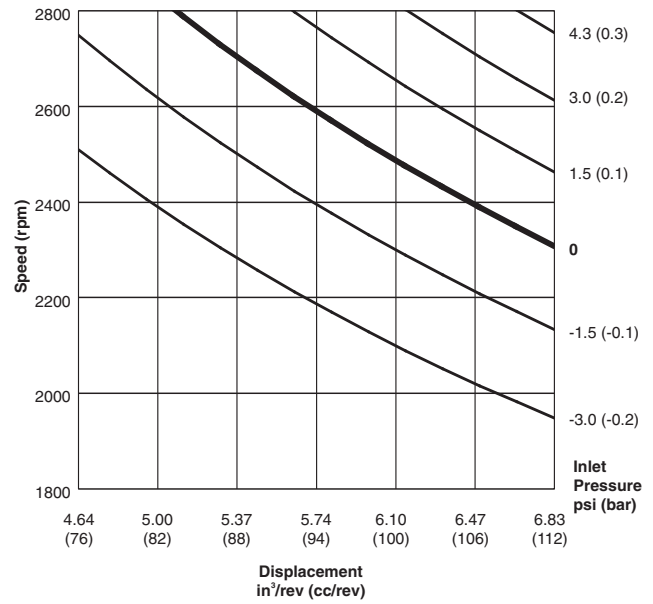

Bearing Life

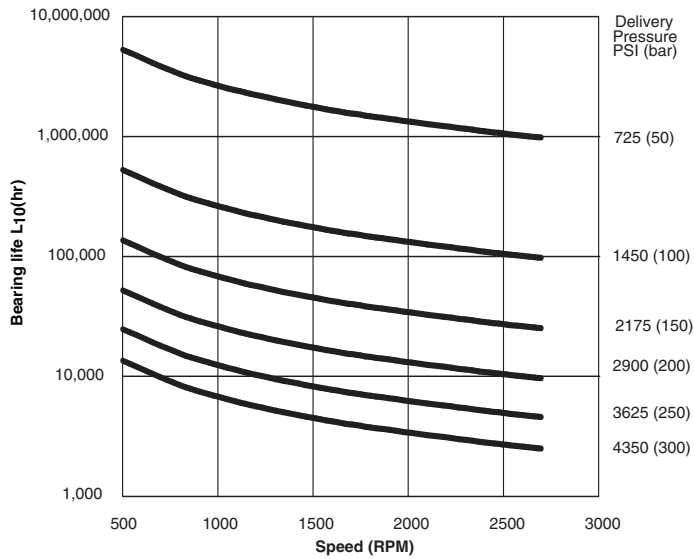

Noise Level

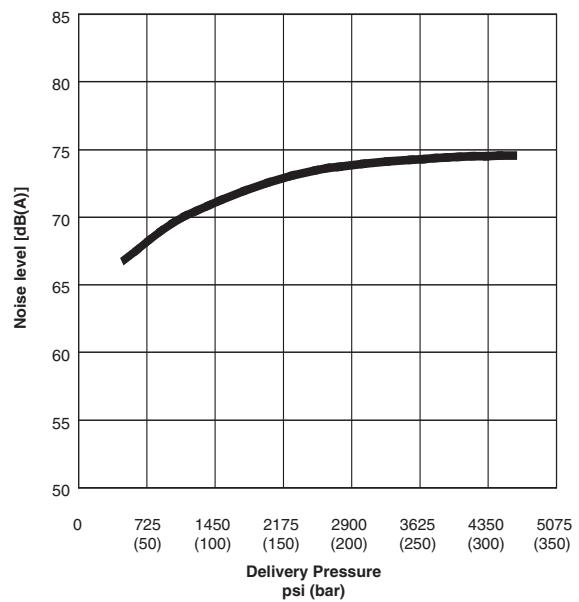

Performance Notes:

- All curves are based on an input speed of 1800 rpm, ISOVG46 hydraulic oil, 122°F (50°C) oil temperature, and 0 psi (0 bar) inlet condition, unless otherwise noted.
- L_{10} bearing life is defined as the period of time for 10% of an identical group of bearings operated under the same conditions to begin to fail as a result of rolling fatigue. Bearing life is further reduced by elevated temperatures, contamination, shaft radial loads, and lubricant breakdown. Consult Kawasaki for detailed bearing life analysis.
- Noise levels are measured in a semi-anechoic chamber in a manner similar to NFPA 13.9.70.12 and DIN 43635
- For application requirements not covered by the performance curves above, consult Kawasaki.

5.0 Performance Curves — K3VL140

Efficiency

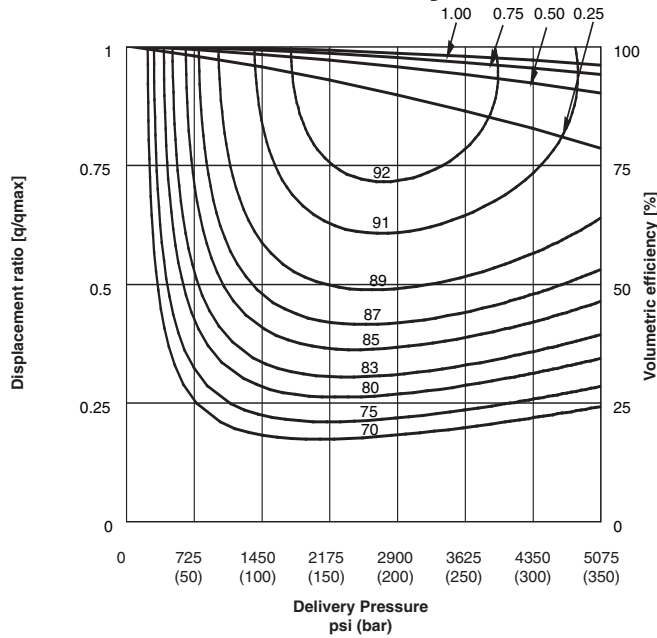

Self-priming Capability

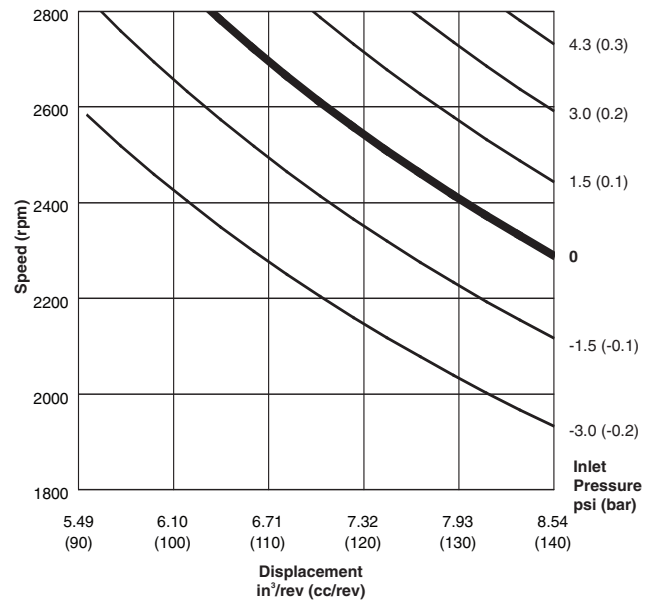

Bearing Life

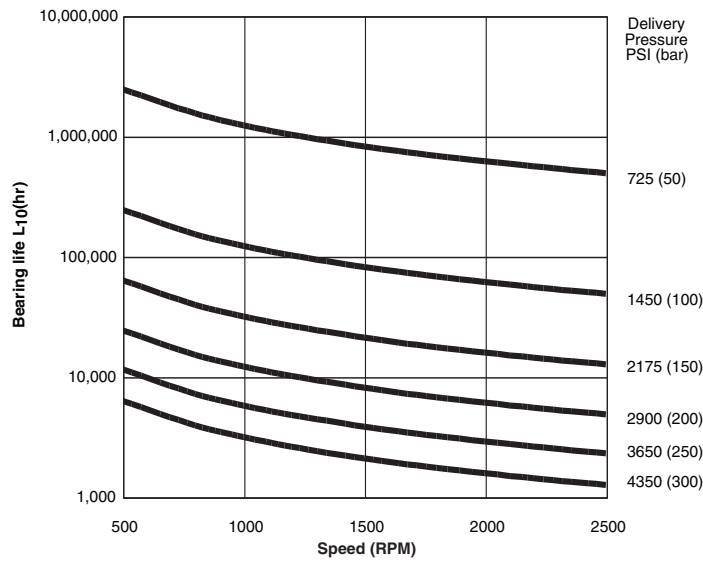

Noise Level

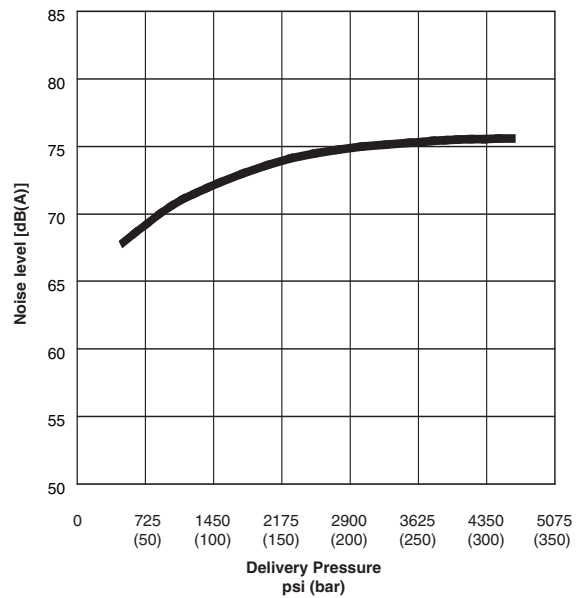

Performance Notes:

- All curves are based on an input speed of 1800 rpm, ISOVG46 hydraulic oil, 122°F (50°C) oil temperature, and 0 psi (0 bar) inlet condition, unless otherwise noted.
- L_{10} bearing life is defined as the period of time for 10% of an identical group of bearings operated under the same conditions to begin to fail as a result of rolling fatigue. Bearing life is further reduced by elevated temperatures, contamination, shaft radial loads, and lubricant breakdown. Consult Kawasaki for detailed bearing life analysis.
- Noise levels are measured in a semi-anechoic chamber in a manner similar to NFPA 13.9.70.12 and DIN 43635
- For application requirements not covered by the performance curves above, consult Kawasaki.

5.0 Performance Curves — K3VL200

Efficiency

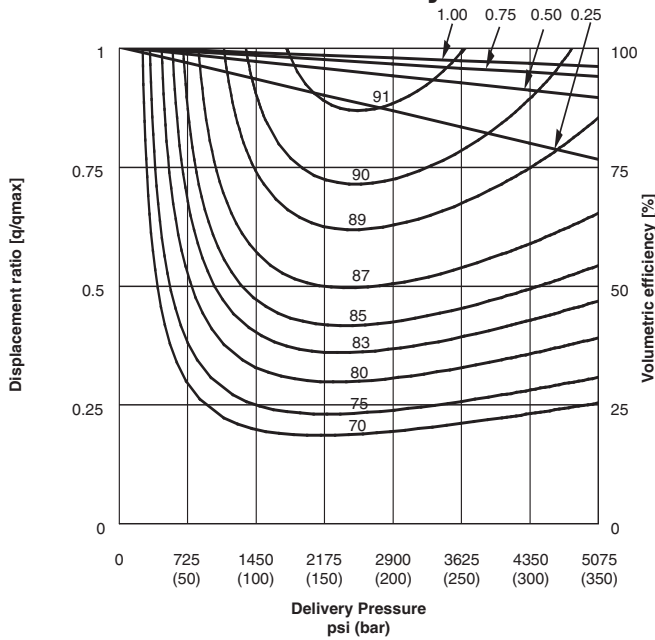

Self-priming Capability

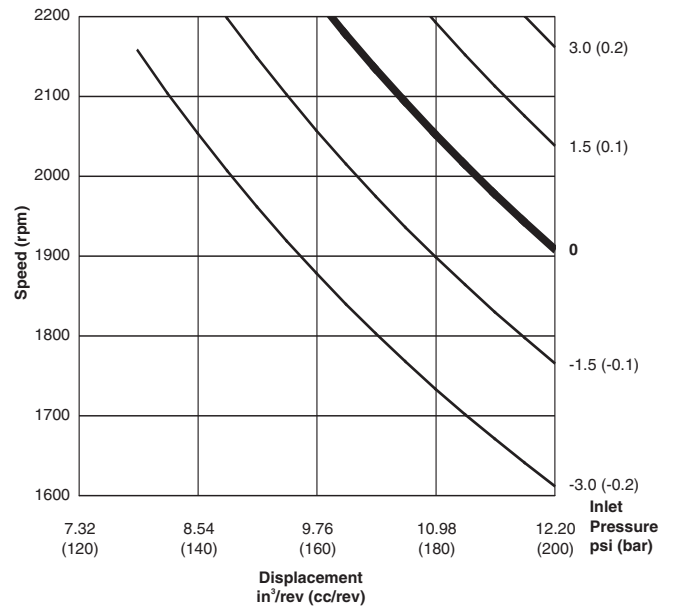

Bearing Life

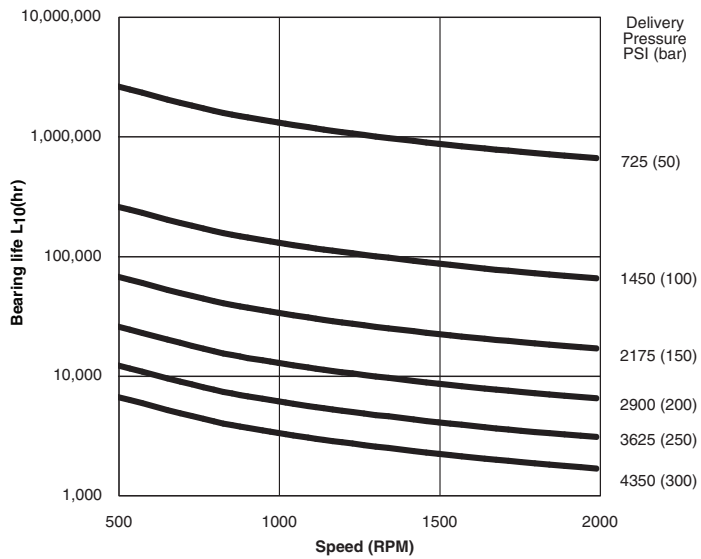

Noise Level

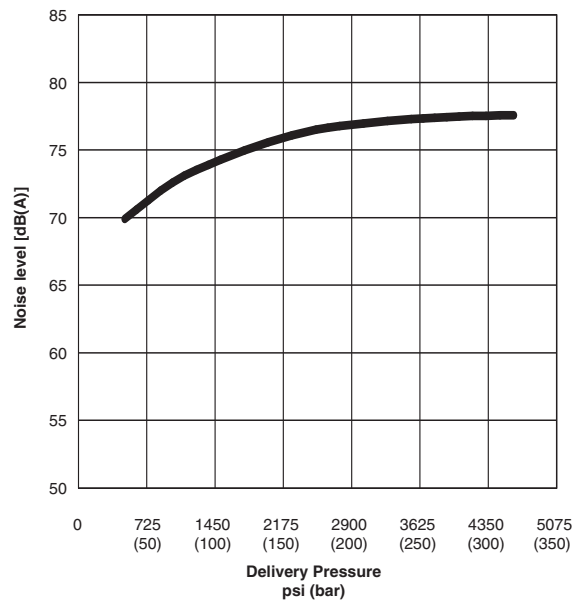

Performance Notes:

1. All curves are based on an input speed of 1800 rpm, ISOVG46 hydraulic oil, 122°F (50°C) oil temperature, and 0 psi (0 bar) inlet condition, unless otherwise noted.
2. L_{10} bearing life is defined as the period of time for 10% of an identical group of bearings operated under the same conditions to begin to fail as a result of rolling fatigue. Bearing life is further reduced by elevated temperatures, contamination, shaft radial loads, and lubricant breakdown. Consult Kawasaki for detailed bearing life analysis.
3. Noise levels are measured in a semi-anechoic chamber in a manner similar to NFPA 13.9.70.12 and DIN 43635
4. For application requirements not covered by the performance curves above, consult Kawasaki.

6.0 Mounting Precautions

Case Drain Recommendations

The pump should be mounted with the drain piping initially rising above the highest point of the pump before continuing to the tank as shown in the second illustration below. This precaution ensures that the case will remain full. Do not connect the drain line to the suction line. The uppermost drain port should be used and the drain piping should be equal to or larger in size than the drain port to minimize pressure in the pump case. The pump case pressure should never exceed 30 psi (2 bar) nominal or 85 psi (6 bar) peak, as shown in the illustration below.

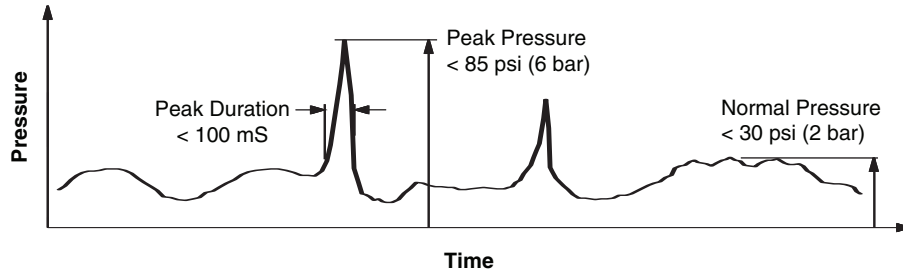

Mounting Pump Above Tank

If the pump is to be mounted above the tank, the case drain line must initially rise above the level of the pump before continuing to the tank as shown in the illustration below. It is possible for oil in the pump case to bleed off to tank, if this precaution is not observed. The maximum height that the center of the pump inlet can be mounted above the oil level is 3.3 feet (1.0 meter). If the pump is mounted upside down, the inlet line must also rise above the level of the pump before continuing to the tank.

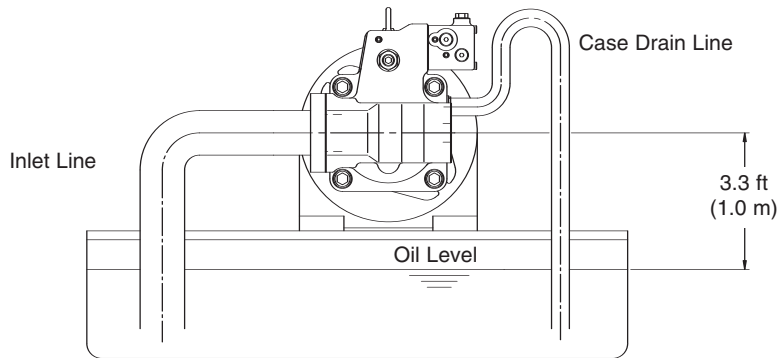

Mounting Pump Vertically

For applications requiring vertical installation (shaft up) remove the plug from the air bleed port (T_{air}). The oil level should be higher than the pump mounting flange as shown in illustration [a] below. If the oil level in the tank is lower than the pump mounting flange, forced lubrication is required through the air bleed port [0.25 ~ 0.50 GPM (1 ~ 2 l/min)].

When installing the pump in the tank and submerged in the oil, open the drain port (Dr) and air bleed port (T_{air}) to provide adequate lubrication to the internal components. When installing the pump outside the tank, run piping for the drain and air bleed ports to tank as shown in illustration [c]. If the drain or air bleed piping rise above the level of oil, as in illustration [b], fill the lines with oil before operation.

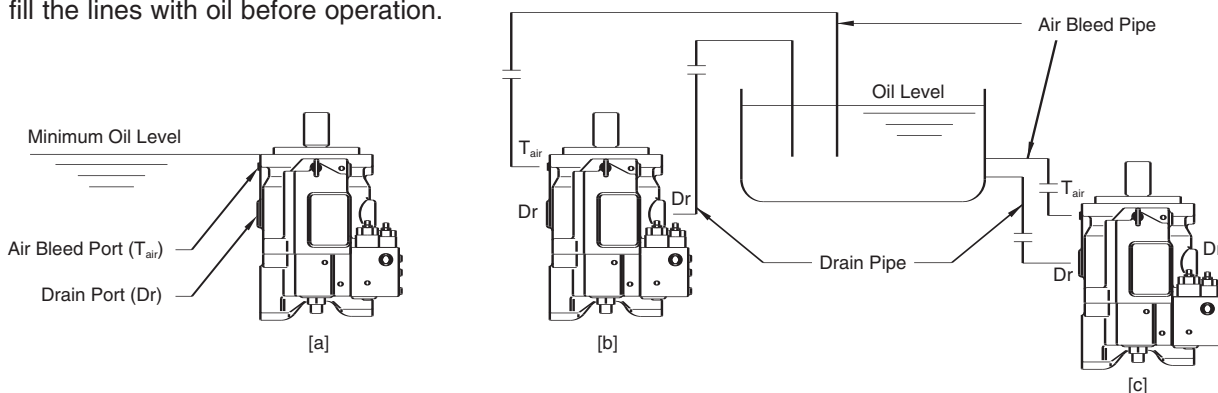

7.0 Filtration

For satisfactory pump service life, the oil should be continuously filtered to a cleanliness level of 20/18/15 ISO/DIS 4406 (NAS Class 9). As a minimum precaution, a 10 μ nominal filter should be installed in the return line and an 80~150 mesh strainer installed in the suction line.

8.0 Hydraulic Fluid Requirements

Use a high quality, anti-wear, mineral based hydraulic fluid when the pressure exceeds 3000 psi (207 bar). Oil viscosity must remain between 55 and 930 SUS (10 and 200 cSt) for normal operation.

In applications where alternate fluids are required (biodegradable fluids, water glycol, phosphate ester, etc.), please consult Kawasaki for recommendations. The seals and ratings may need to be changed to ensure compatibility and reasonable life.

9.0 Initial Start-up

1. Make sure the pump case is filled with clean, filtered fluid identical to that used in the rest of the system. The pump case must be full at all times to ensure proper lubrication of internal components.
2. Verify that piping is completed and any inlet valves are open to prevent cavitation or aeration of the pump.
3. Confirm that the direction of rotation of the prime mover matches the pump installed.
4. Jog start the prime mover with the pump unloaded and operate until the air is bled from the system.
5. Check the pump for external leakage, abnormal noise, and vibration.

10.0 Drive Shaft Coupling

Use a flexible coupling to connect the pump shaft to an engine flywheel or electric motor shaft. Alignment [δ] should be within 0.001 in (0.025 mm) parallel and 0.2° angular [α] as shown in the illustration below.

Do not apply any axial loading to the pump shaft. For applications where radial, or side, loads exist please contact Kawasaki for recommendations and bearing life analysis.

Do not hammer the coupling on or off the pump keyed shaft. Use the threaded hole in the end of the pump shaft to fix or remove the coupling.

Dial Gauge [Reading "a"]
 $\delta = a/2 \leq 0.001\text{in (0.025mm)}$

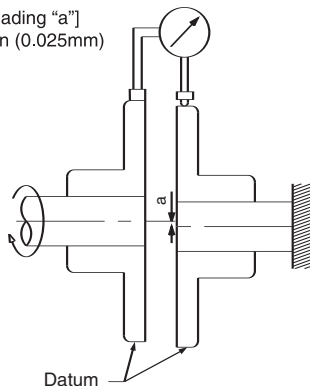

Dial Gauge [Reading "b"]
 $\alpha = \sin^{-1}(b/D) \leq 0.2^\circ$

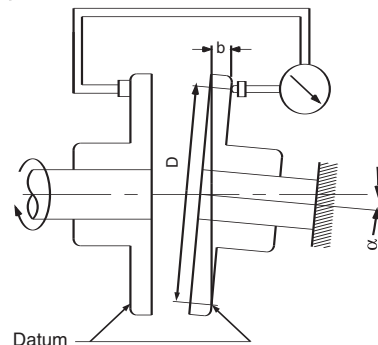

11.0 Installation Drawings

K3VL45/60 With Cut-off/Load Sense Control And Torque Limit Module (Clockwise Rotation)

Inlet and outlet ports reversed for counter clockwise rotation

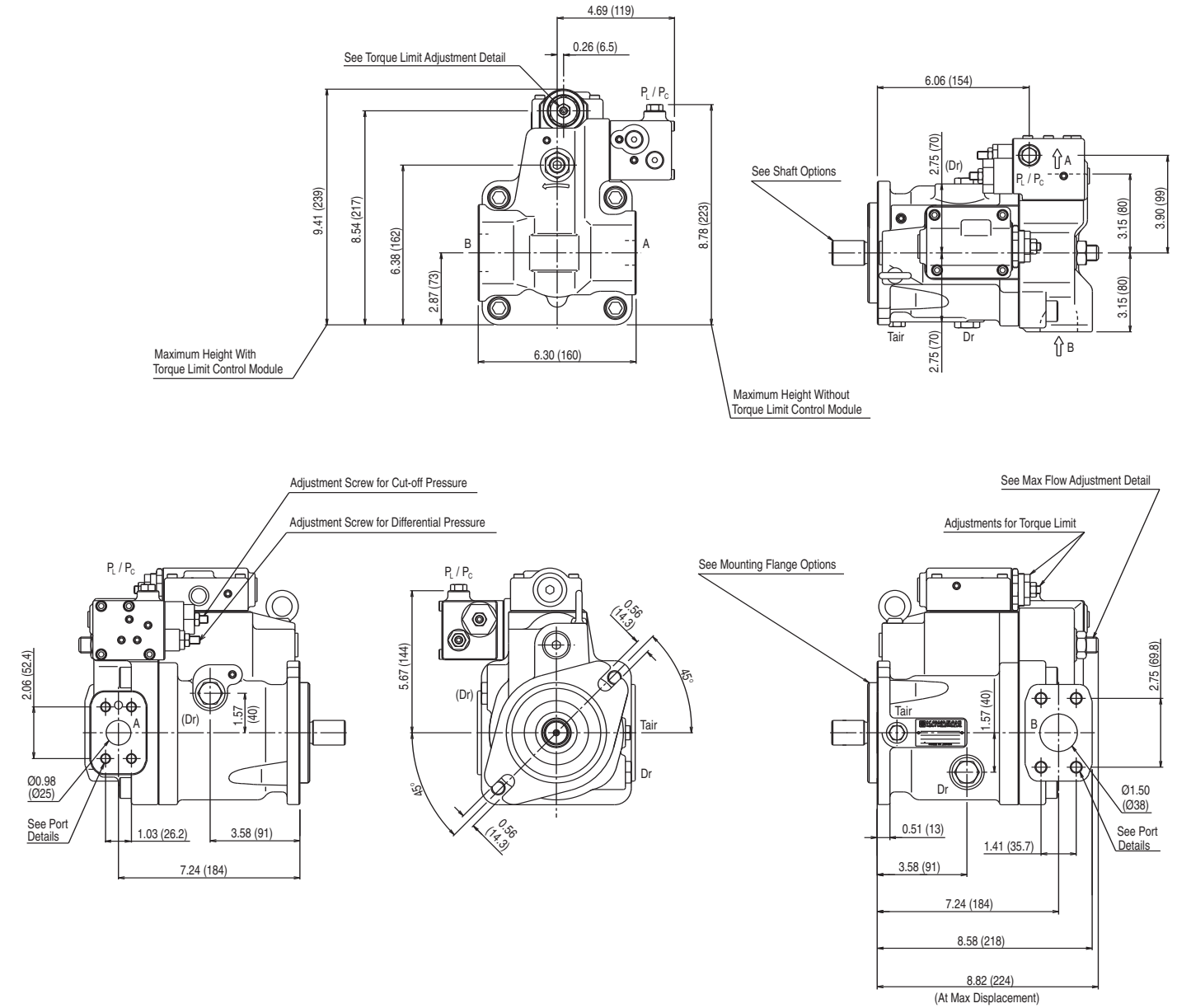

Port Details

Port Name	Port Size and Description	Tightening Torque lbf-ft (Nm)
A	Delivery Port 1" SAE J518C Code 61 (5000 psi) Unified Thread Type "S": 3/8" - 16 - 2B (0.71" depth)	42 (57)
B	Inlet Port 1-1/2" SAE J518C Code 61 (3000 psi) Unified Thread Type "S": 1/2" - 13 - 2B (0.87" depth)	72 (98)
Dr	Drain Port "S" Type: 1/2" O-Ring Boss - SAE J1926/1 (3/4" - 16UNF - 2B)	72 (98)
P ₁ /P _c	P0/L0 Control Port "S" Type: 1/4" O-Ring Boss - SAE J1926/1 (7/16" - 20UNF - 2B)	9 (12)
Tair	Air Bleed Port "S" Type: 1/4" O-Ring Boss - SAE J1926/1 (7/16" - 20UNF - 2B)	9 (12)

Dimensions shown in inches and (millimeters) unless noted otherwise.

Mounting Flange

Model Code Options "K" or "S"

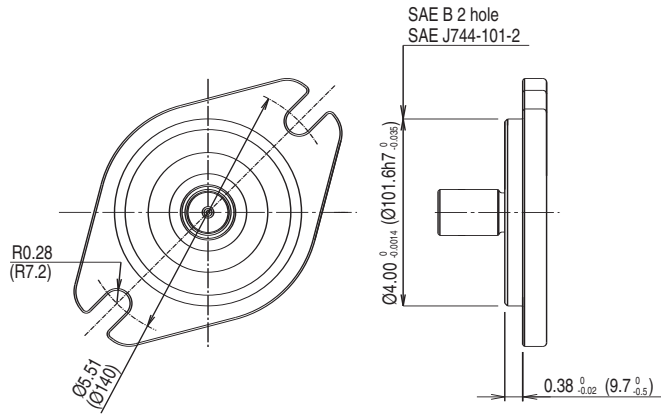

Shafts

Model Code Option "K"

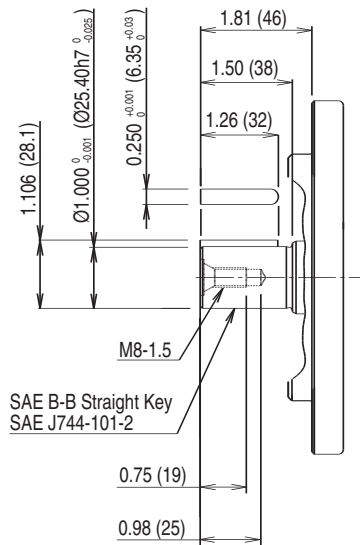

Model Code Option "S"

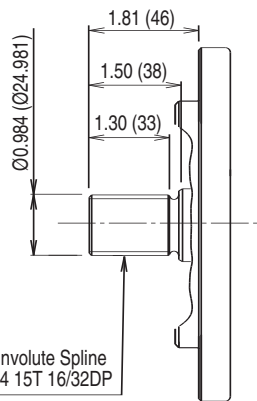

Model Code Option "T"

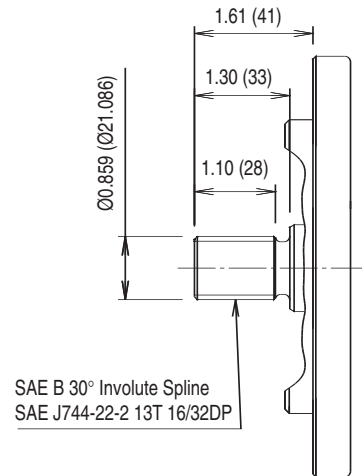

Rear Ports

Model Code Option "R"

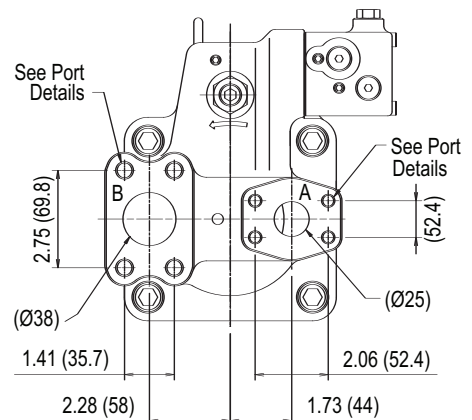
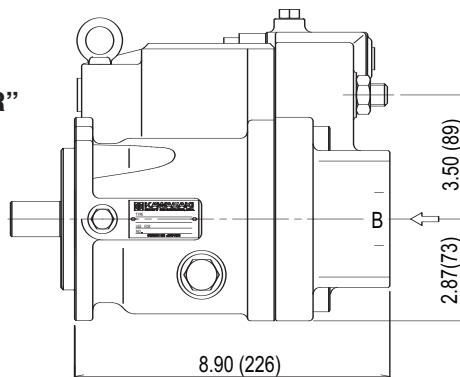

11.0 Installation Drawings (Continued)

K3VL80 With Cut-off/Load Sense Control And Torque Limit Module (Clockwise Rotation)

Inlet and outlet ports reversed for counter clockwise rotation

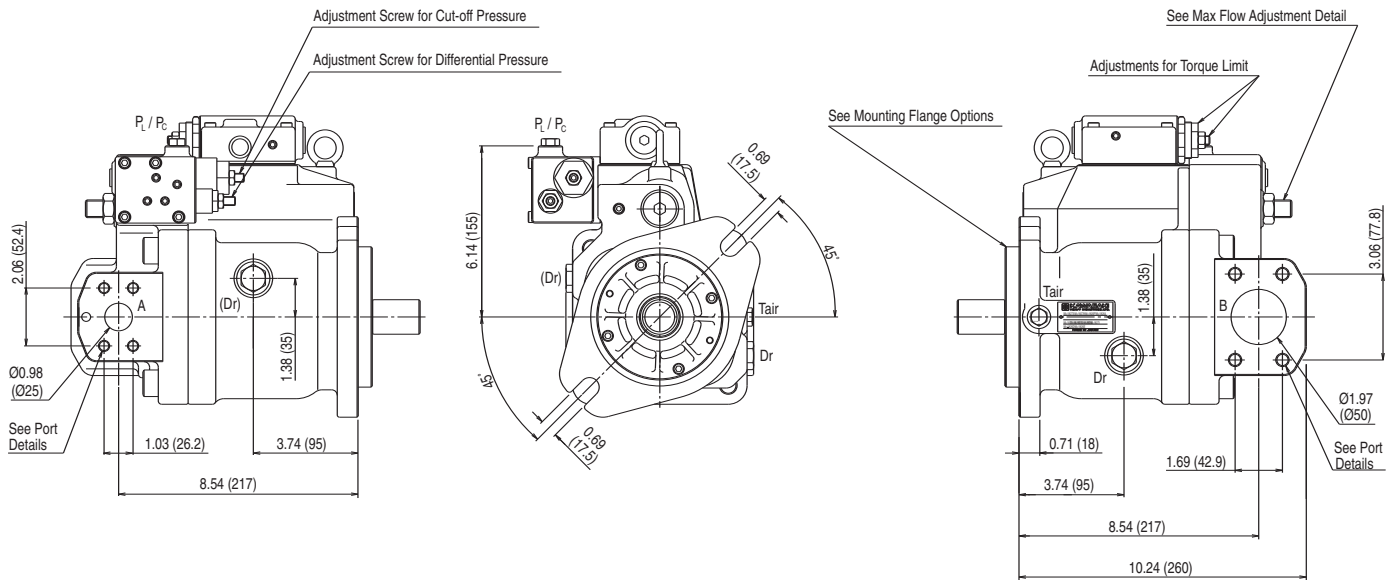
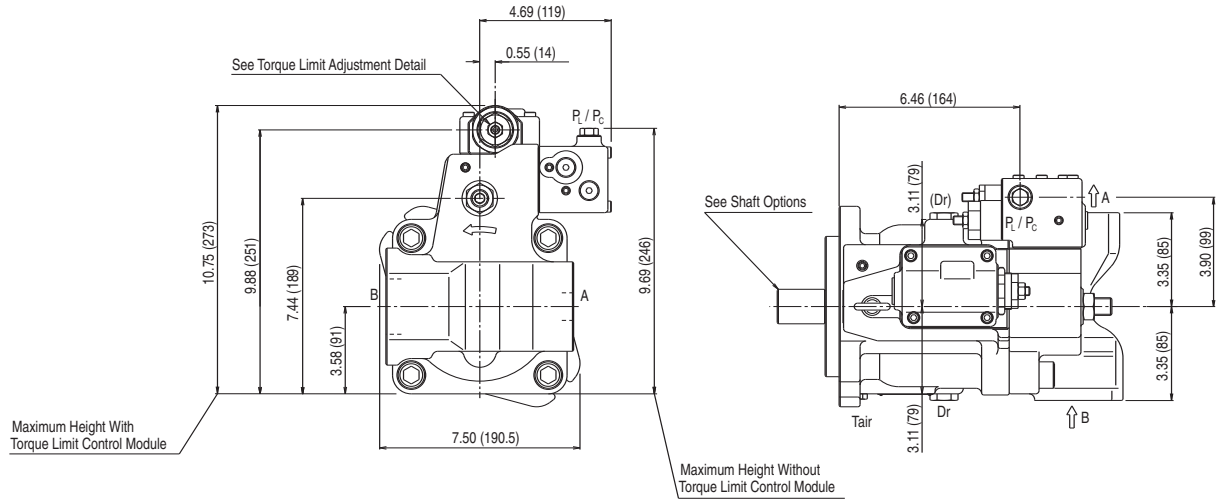

Port Details

Port Name	Port Size and Description	Tightening Torque lbf-ft (Nm)
A	Delivery Port 1" SAE J518C Code 61 (5000 psi) Unified Thread Type "S": 3/8" - 16 - 2B (0.71" depth)	42 (57)
B	Inlet Port 2" SAE J518C Code 61 (3000 psi) Unified Thread Type "S": 1/2" - 13 - 2B (0.87" depth)	72 (98)
Dr	Drain Port "S" Type: 1/2" O-Ring Boss - SAE J1926/1 (3/4" - 16UNF - 2B)	72 (98)
P _L / P _C	P0/L0 Control Port "S" Type: 1/4" O-Ring Boss - SAE J1926/1 (7/16" - 20UNF - 2B)	9 (12)
Tair	Air Bleed Port "S" Type: 1/4" O-Ring Boss - SAE J1926/1 (7/16" - 20UNF - 2B)	9 (12)

Dimensions shown in inches and (millimeters) unless noted otherwise.

Mounting Flange

Model Code Options "K" or "S"

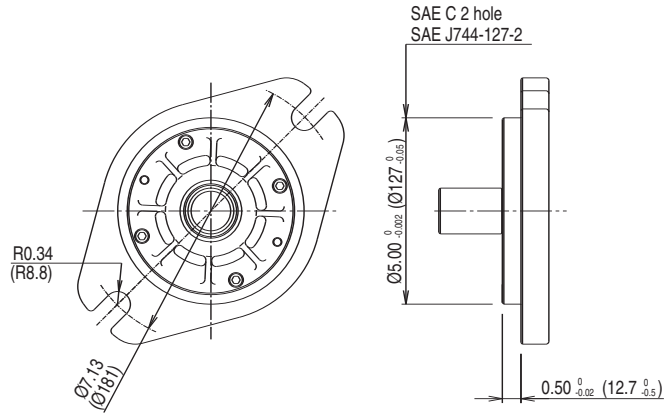

Shafts

Model Code Option "K"

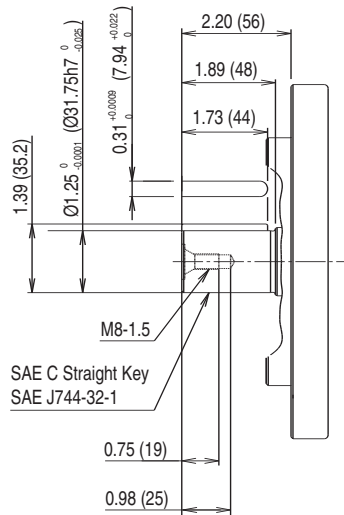

Model Code Option "S"

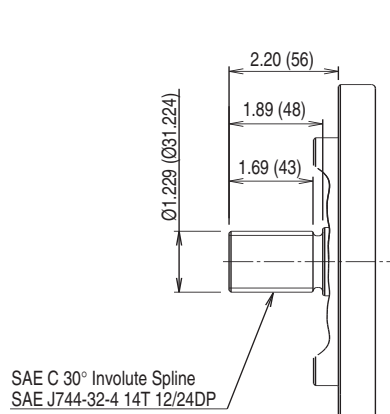

Rear Ports

Model Code Option "R"

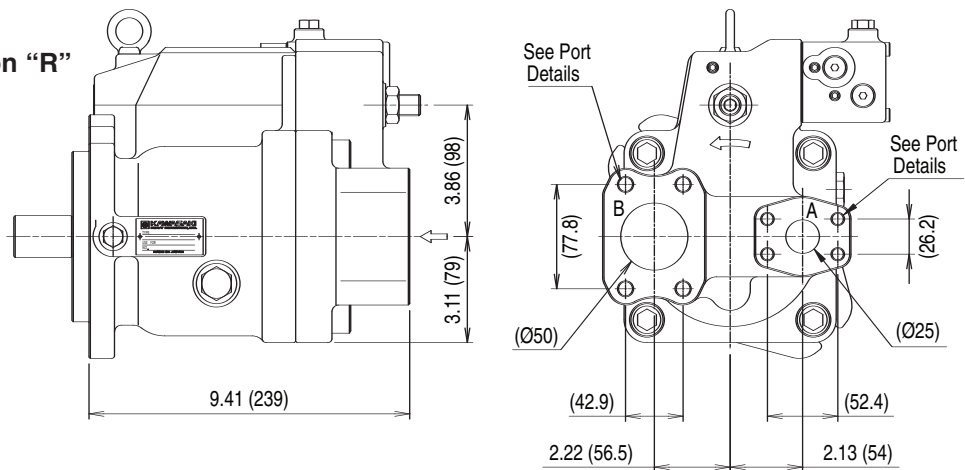

11.0 Installation Drawings (Continued)

K3VL112/140 With Cut-off/Load Sense Control And Torque Limit Module (Clockwise Rotation)

Inlet and outlet ports reversed for counter clockwise rotation

Standard Mounting (SAE D)

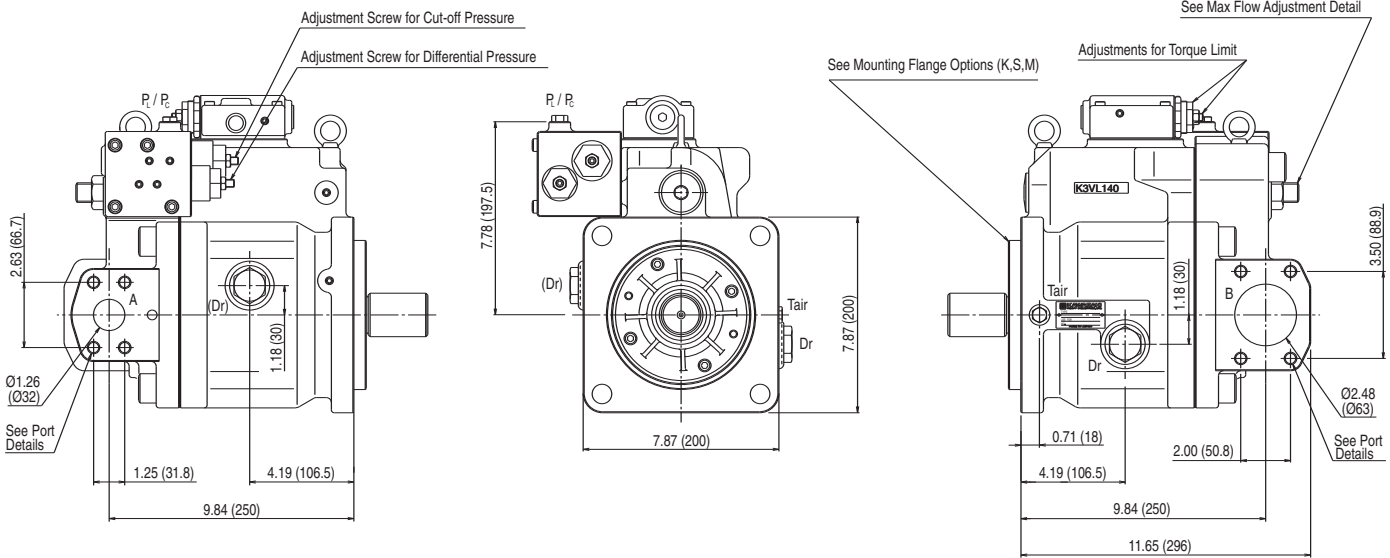
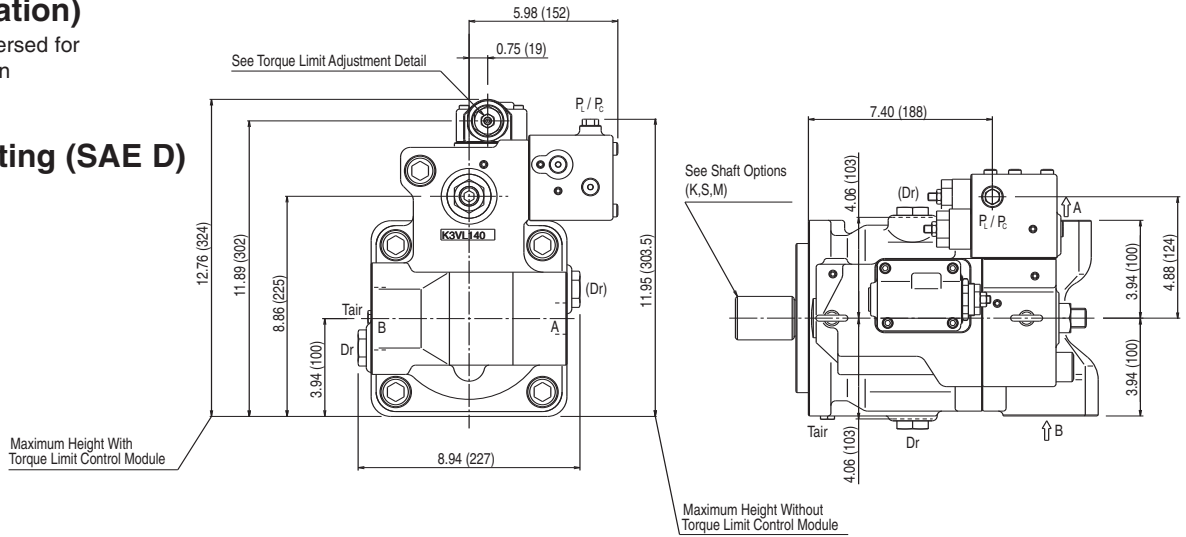

Port Details

Port Name	Port Size and Description	Tightening Torque lbf-ft (Nm)
A	Delivery Port 1-1/4" SAE J518C Code 62 (6000 psi) Unified Thread Type "S": 1/2" - 13 - 2B (0.87" depth)	72 (98)
B	Inlet Port 2-1/2" SAE J518C Code 61 (2500 psi) Unified Thread Type "S": 1/2" - 13 - 2B (0.87" depth)	72 (98)
Dr	Drain Port "S" Type: 3/4" O-Ring Boss - SAE J1926/1 (1-1/6" - 12UNF - 2B)	123 (167)
R _i / P _c	P0/L0 Control Port "S" Type: 1/4" O-Ring Boss - SAE J1926/1 (7/16" - 20UNF - 2B)	9 (12)
Tair	Air Bleed Port "S" Type: 1/4" O-Ring Boss - SAE J1926/1 (7/16" - 20UNF - 2B)	9 (12)

Dimensions shown in inches and (millimeters) unless noted otherwise.

Optional Mounting (SAE C)

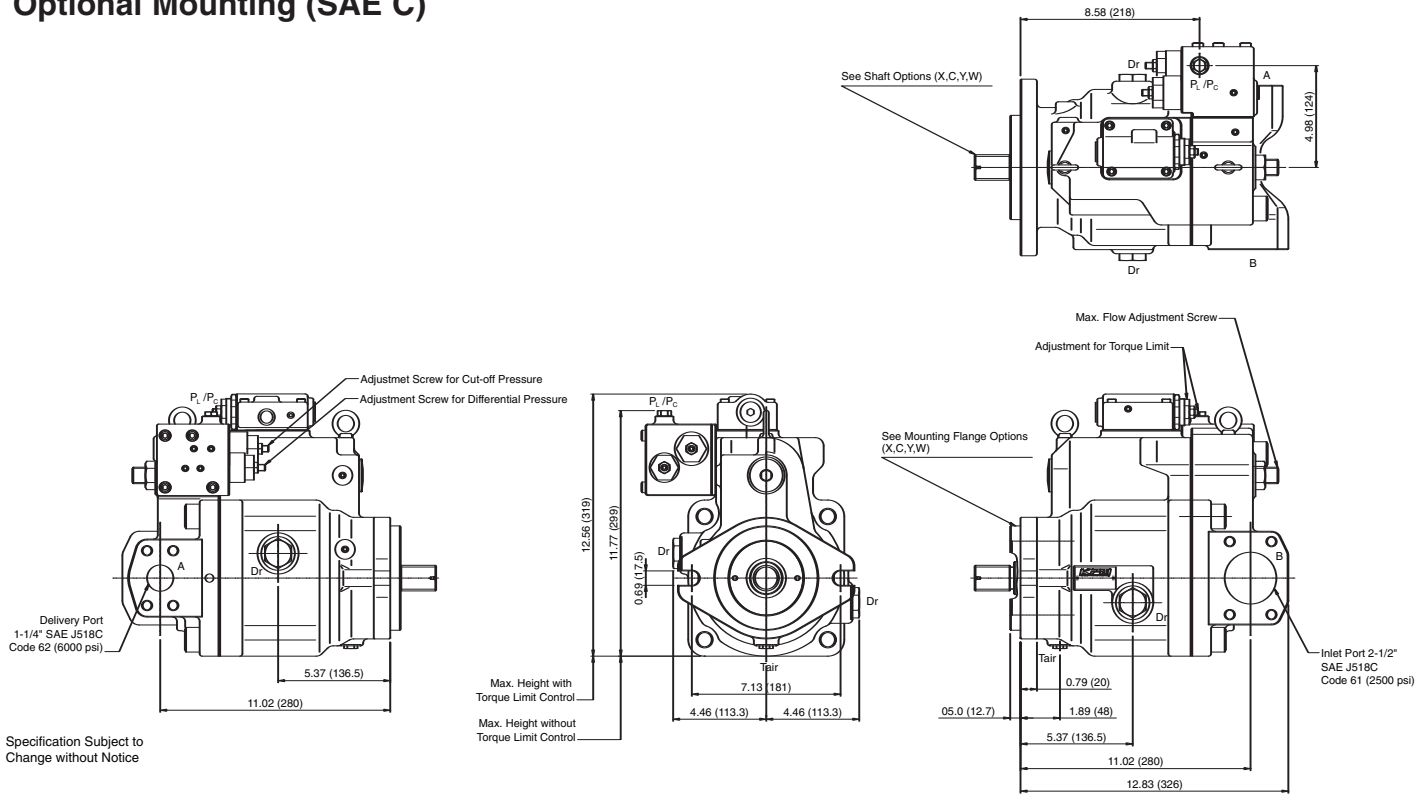

Specification Subject to Change without Notice

Shafts

Model Code Option "K"

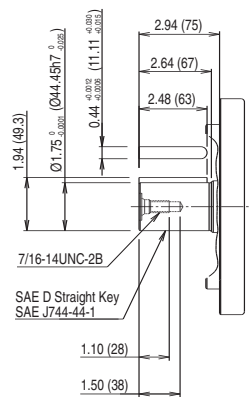

Model Code Option "S"

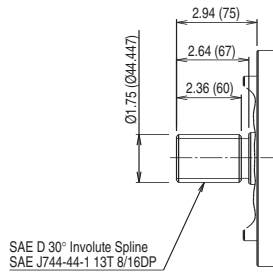

Model Code Option "X"

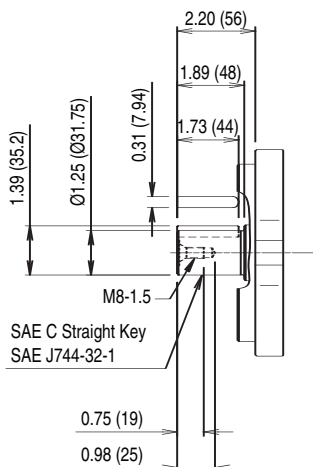

Model Code Option "C"

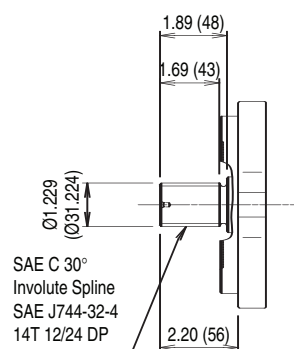

Model Code Option "Y"

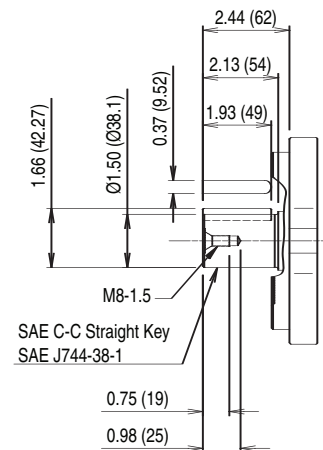

Model Code Option "W"

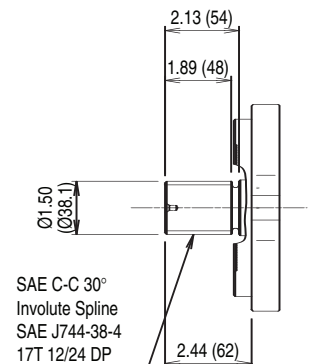

11.0 Installation Drawings (Continued)

K3VL200 With Cut-off/Load Sense Control And Torque Limit Module (Clockwise Rotation)

Inlet and outlet ports reversed
for counter clockwise rotation

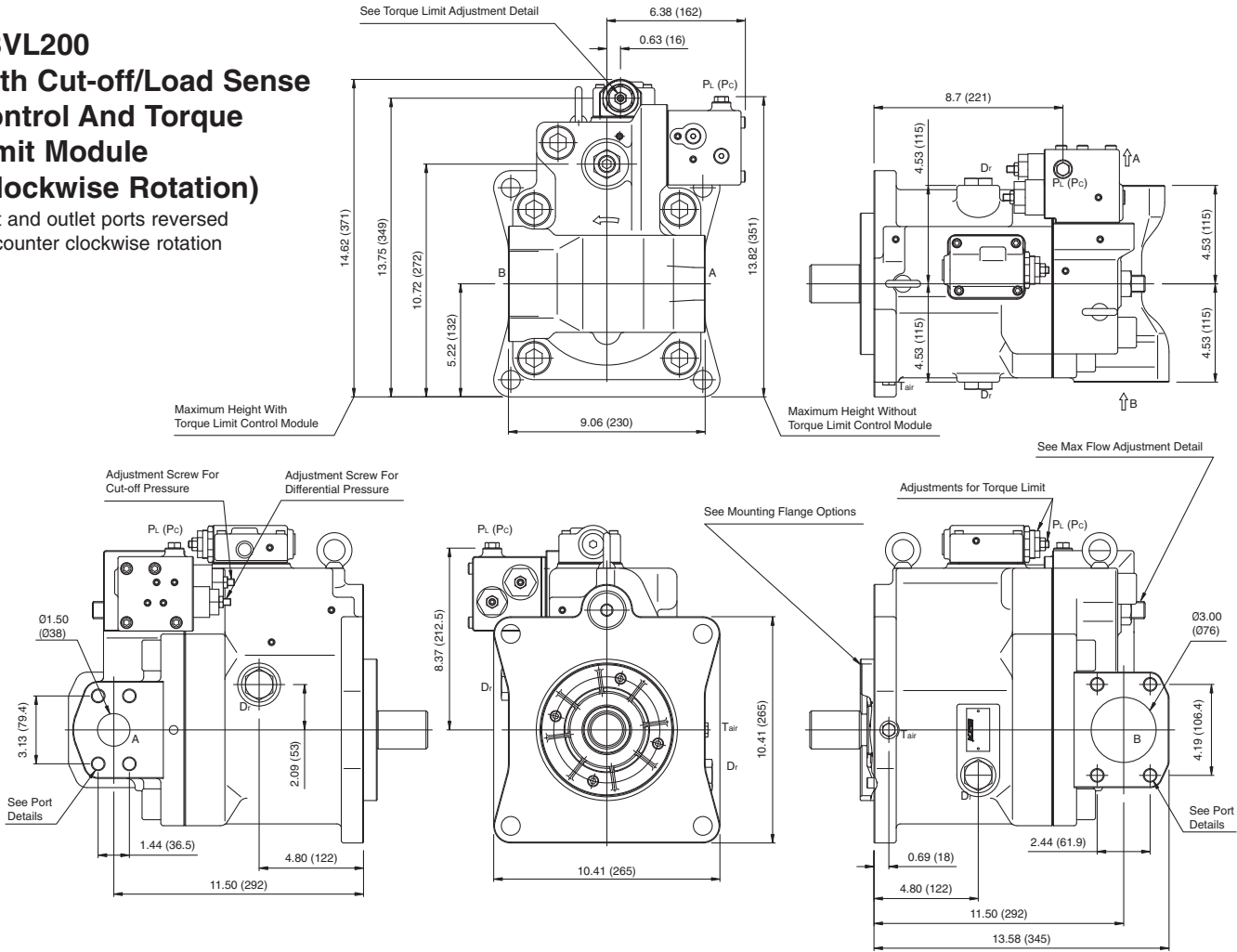

Mounting Flange

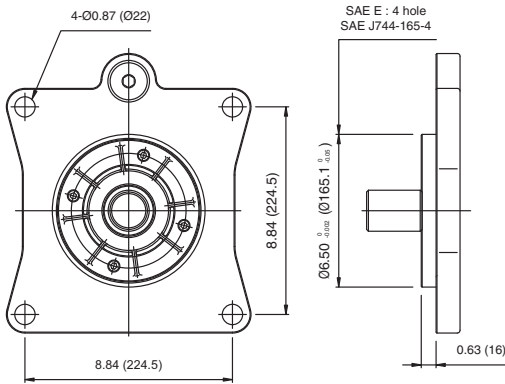

Model Code Option "S"

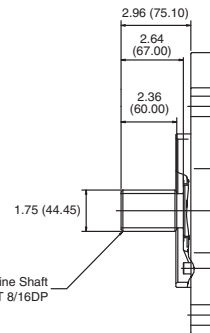

Model Code Option "K"

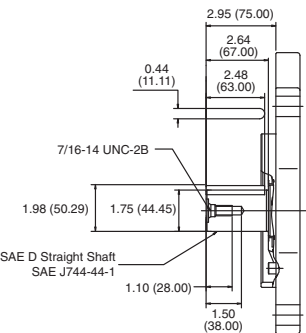

Port Details

	Port Name	Port Size and Description	Tightening Torque lbf-ft (Nm)
A	Delivery Port	1-1/2" SAE J518C Code 62 (6000 psi) Unified Thread Type "S": 5/8" - 11 - 2B (.98" depth)	173 (235)
B	Inlet Port	3" SAE J518C Code 61 (2000 psi) Unified Thread Type "S": 5/8" - 11 - 2B (.98" depth)	173 (235)
Dr	Drain Port	"S" Type: 3/4" O-Ring Boss - SAE J1926/1 (1-1/6" - 12UNF - 2B)	123 (167)
P _i / P _c	P0/L0 Control Port	"S" Type: 1/4" O-Ring Boss - SAE J1926/1 (7/16" - 20UNF - 2B)	9 (12)
Tair	Air Bleed Port	"S" Type: 1/4" O-Ring Boss - SAE J1926/1 (7/16" - 20UNF - 2B)	9 (12)

Dimensions shown in inches and (millimeters) unless noted otherwise.

12.0 Response Time

Pressure Cut-off Dynamic Response

50 to 280 bar (725 to 4060 psi)

	$t_{\text{off-stroke}}$	$t_{\text{on-stroke}}$
Unit	mS	
K3VL45/60	60	100
K3VL80	95	170
K3VL112	90	140
K3VL140	90	140
K3VL200	110	240

Test Conditions:

Pump Speed = 1800 rpm
 Inlet Condition = 0 psi (bar)
 Oil Type = ISO VG46
 Oil Temperature = 122°F (50°C)
 Compressed Oil Volume = 1.32 gallons (5 liters)

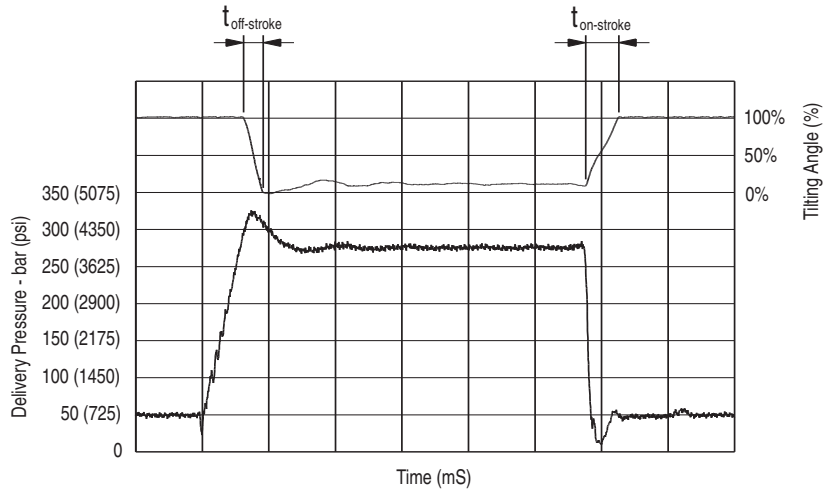

220 to 280 bar (3190 to 4060 psi)

	$t_{\text{off-stroke}}$	$t_{\text{on-stroke}}$
Unit	mS	
K3VL45/60	60	70
K3VL80	100	110
K3VL112	100	120
K3VL140	100	120
K3VL200	110	120

Test Conditions:

Pump Speed = 1800 rpm
 Inlet Condition = 0 psi (bar)
 Oil Type = ISO VG46
 Oil Temperature = 122°F (50°C)
 Compressed Oil Volume = 1.32 gallons (5 liters)

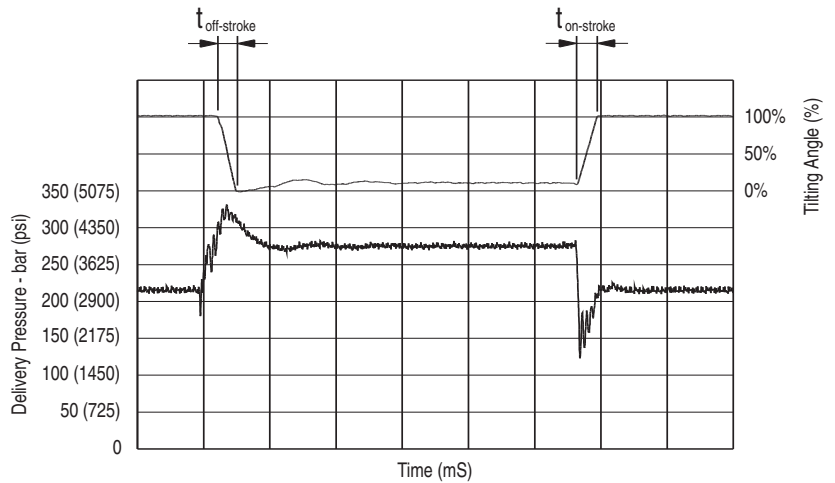

Load Sensing Dynamic Response

20 to 280 bar (290 to 4060 psi)

	$t_{\text{off-stroke}}$	$t_{\text{on-stroke}}$
Unit	mS	
K3VL45/60	20	115
K3VL80	55	115
K3VL112	50	195
K3VL140	50	195
K3VL200	65	190

Test Conditions:

Pump Speed = 1800 rpm
 Inlet Condition = 0 psi (bar)
 Oil Type = ISO VG46
 Oil Temperature = 122°F (50°C)
 Compressed Oil Volume = 1.32 gallons (5 liters)

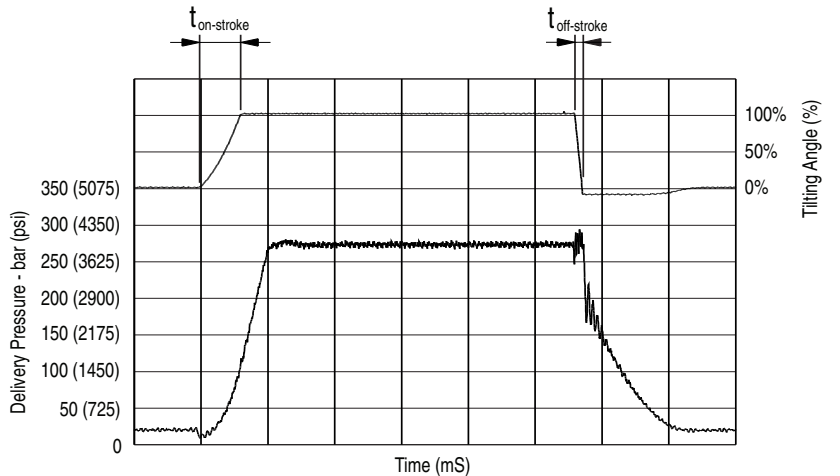

Note: The response values shown in the tables above are typical of those experienced in the laboratory. Actual response time will vary with different hydraulic circuits.

13.0 Through Drives

Pump Frame Size (K3VL cc/rev)		45,60,80,112,140,200			200	80,112,140,200		112,140,200	200
Mounting Code		A	B	BB	C4	C	CC	D	E
	Pilot Diameter	3.25 (82.55)	4.000 (101.60)		5.000 (127.0)			6.000 (152.4)	6.50 (165.1)
	Pilot Depth	0.315 (8.0)	0.433 (11.0)		0.551 (14.0)			0.551 (14.0)	0.710 (18)
Dimensions [in (mm)]	Mounting Bolt Hole Thread	M10 - 1.5	M12 - 1.75		M12 - 1.75	M16 - 2.0			M20 - 2.5
	Shaft Length	1.358 (34.5)	1.929 (46.0)		2.185 (55.5)			2.756 (70.0)	
	Spline Engagement	0.984 (25.0)	1.535 (39.0)		1.772 (45.0)			2.480 (63.0)	
Shaft Spline Detail [in (mm)]	Standard	SAE Flat Root Side Fit - Tolerance Class 5							
	Number of Teeth	9	13	15	14	17		13	
	Diametral Pitch	16/32			12/24			8/16	
	Pressure Angle	30°							
	Major Diameter	0.625 (15.875)	0.875 (22.225)	1.000 (25.4)	1.283 (32.588)	1.533 (38.938)		1.850 (46.990)	
	Internal Diameter Over Pins	0.397 (10.089)	0.653 (16.589)	0.780 (19.807)	0.961 (24.407)	1.207 (30.648)		1.301 (33.056)	
	Pin Diameter	0.108 (2.743)			0.144 (3.658)			0.216 (5.486)	
Allowable Torque [lbf-ft (Nm)]		45 (31)	150 (203)	166 (226)	295 (400)	412 (559)		516 (699)	

Kit Detail

SAE A Kit (K3VL 45-140)

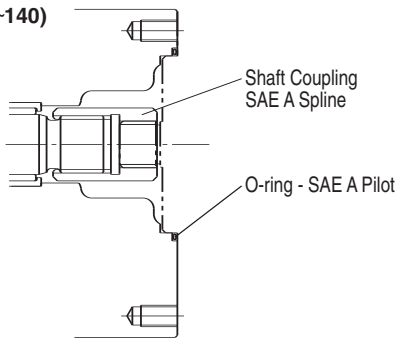

SAE B-D Kits (K3VL 45-140)

SAE A-E Kits (K3VL 200)

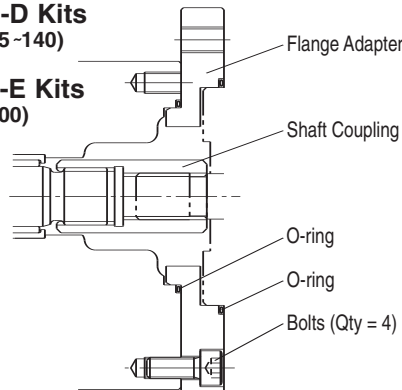

CAUTION: Second pump should have solid pilot so o-ring can seal against the corner.

Bending Moment Limitation

	Symbol	Units	K3VL45/60	K3VL80	K3VL112/140	K3VL200
Maximum Allowable Bending Moment	Bmax	lbf-ft (Nm)	101 (137)	180 (244)	341 (462)	685 (930)
Pump Weight Without Through Drive	M	lb (kg)	55 (25)	77 (35)	143 (65)	209 (95)
Pump Weight With SAE A Through Drive	Ma	lb (kg)	62 (28)	84 (38)	152 (69)	226 (103)
Pump Weight With SAE B/BB Through Drive	Mb	lb (kg)	73 (33)	97 (44)	167 (76)	249 (113)
Pump Weight With SAE C/CC Through Drive	Mc	lb (kg)	-	99 (45)	172 (78)	249 (113)
Pump Weight With SAE D Through Drive	Md	lb (kg)	-	-	183 (83)	253 (115)
Pump Weight With SAE E Through Drive	Me	lb (kg)	-	-	-	264 (120)
Distance from Mounting Face to Pump Center of Gravity Not Including Through Drive Kit	d2	in (mm)	4.72 (120)	5.12 (130)	5.91 (150)	7.48 (190)
Distance from Mounting Face to Pump Center of Gravity Including Through Drive Kit (Approximation)	d1	in (mm)	5.12 (130)	5.71 (145)	6.89 (175)	8.47 (215)
Through Drive Pump Length from Front to Rear Mounting Flanges	D#	in (mm)	See Page 26 With through drive pump length			

Bending moment for tandem pump = $[Ma - e \times d1] + [M \times (d2 + D\#)]$. If the result exceeds the maximum allowable bending moment, then additional support is required. Consult Kawasaki in this case.

K3VL45 – 140 Through Drive Installation Details

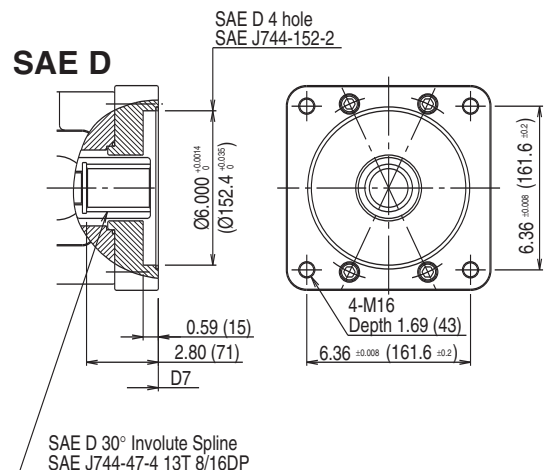
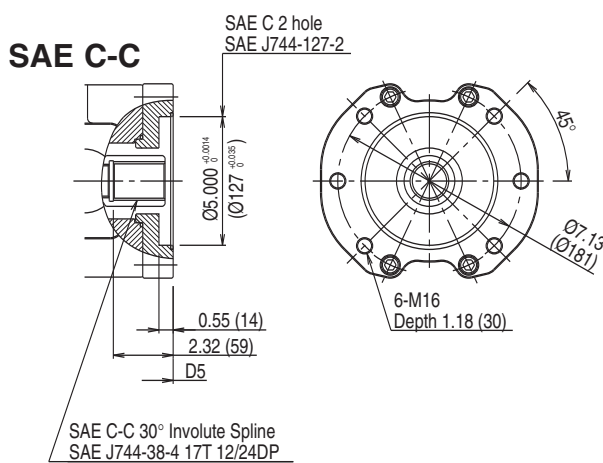
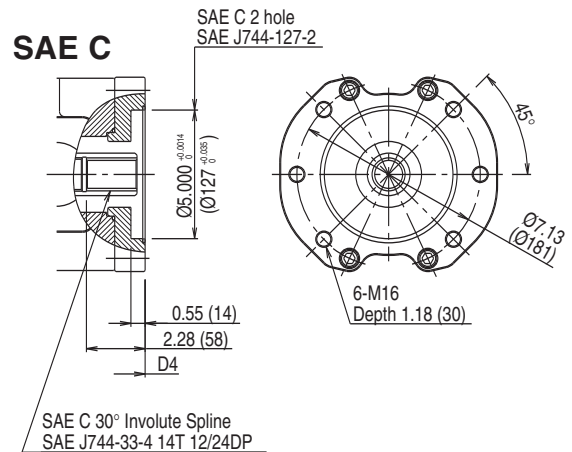
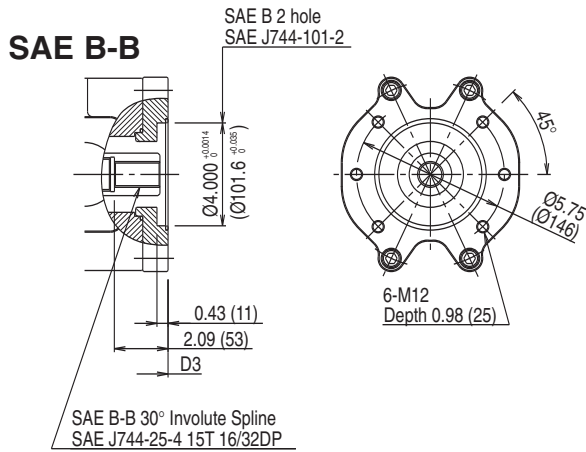
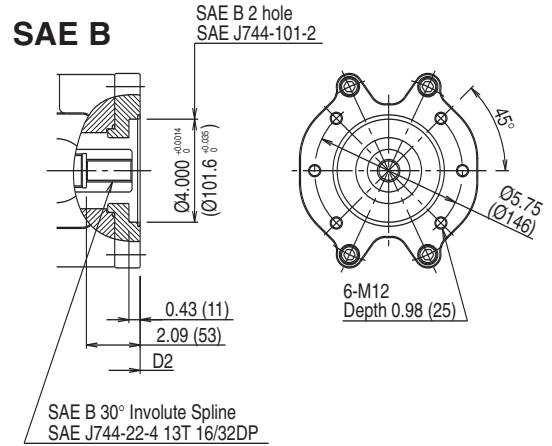
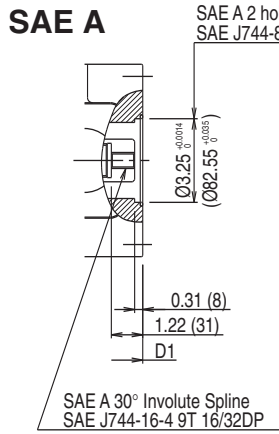

Through Drive Pump Length From Front to Rear Mounting Flanges

Note	Interface	Units	K3VL45/60	K3VL80	K3VL112/140	K3VL200
D1	SAE A	in (mm)	9.61 (244.0)	10.71 (272.0)	12.11 (307.5)	14.37 (365)
D2	SAE B		10.39 (264.0)	11.50 (292.0)	13.09 (332.0)	15.12 (384)
D3	SAE B-B		-	11.50 (292.0)	13.09 (332.0)	15.12 (384)
D4	SAE C		-	11.67 (296.5)	13.29 (337.5)	15.12 (384)
D5	SAE C-C		-	-	13.29 (337.5)	15.12 (384)
D6	SAE C-4		-	-	-	15.12 (384)
D7	SAE D		-	-	13.80 (350.5)	15.63 (397)
D8	SAE E		-	-	-	15.63 (397)

WARNING: Do not attempt to use UNC threaded bolts in METRIC bolt holes.

K3VL200 Through Drive Installation Details

SAE A

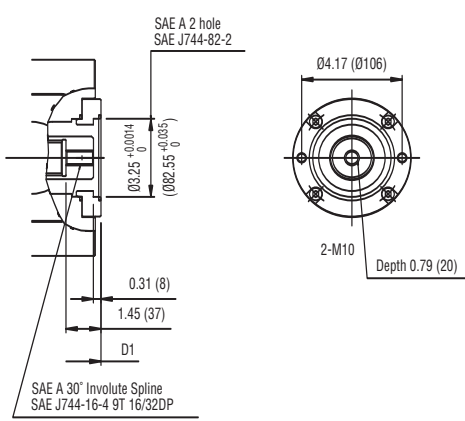

SAE B

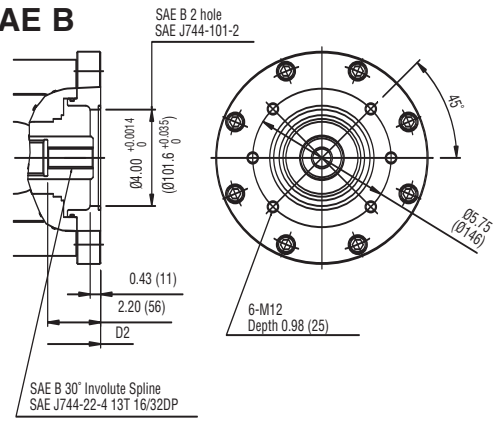

SAE B-B

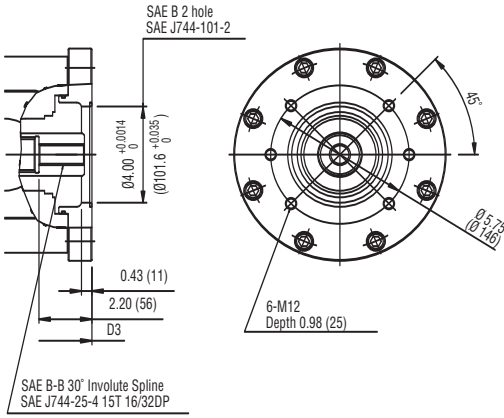

SAE C-2

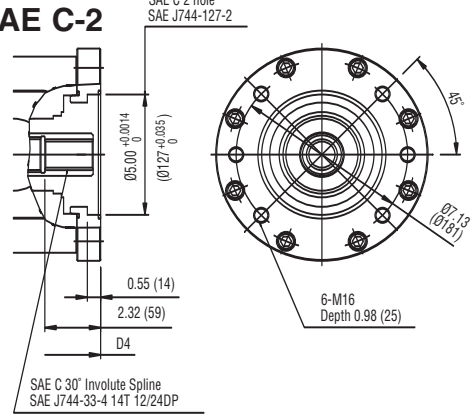

SAE C-C

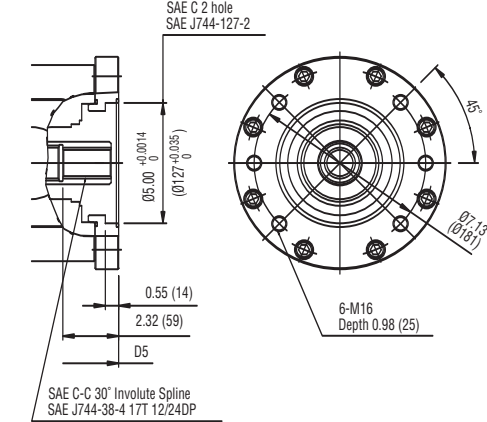

SAE C-4

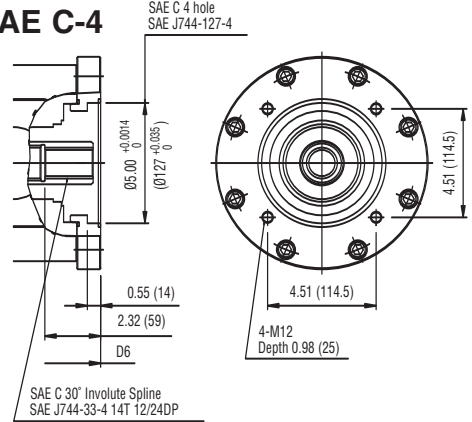

SAE D

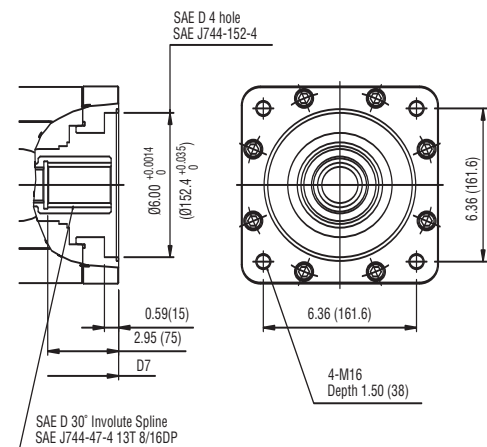

SAE E

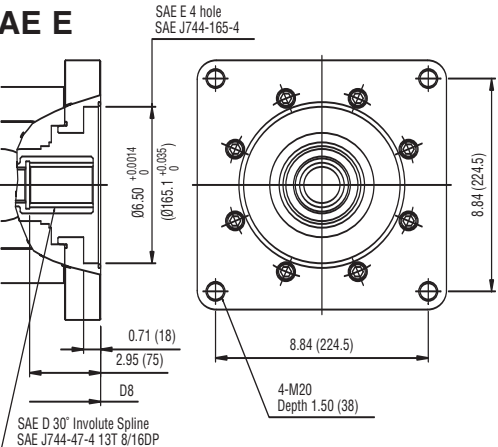

14.0 Pump Controls

Max Flow Adjustment

Flow Adjustment	Unit	K3VL45	K3VL60	K3VL80	K3VL112	K3VL140	K3VL200
Adjustment Screw: Internal Hex size	mm	8	8	8	10	10	10
Displacement Per Screw Revolution	in ³ (cm ³)	0.3 (4.9)	0.37 (6.1)	0.36 (6.0)	0.70 (11.5)	0.73 (12.0)	0.93 (15.3)
Displacement Adjustment Range	in ³ (cm ³)	0.98 - 2.75 (16 - 45)	1.65 - 3.70 (24 - 60)	2.15 - 4.88 (35 - 80)	3.42 - 6.83 (56 - 112)	4.27 - 8.54 (70 - 140)	6.1 - 12.2 (100 - 200)
Exposed Screw Length (L)	in (mm)	0.02 - 0.47 (0.5 - 12.1)	0.02 - 0.47 (0.5 - 12.1)	0.02 - 0.59 (0.5 - 15.0)	0.14 - 0.63 (3.8 - 16)	0.04 - 0.63 (1.0 - 16)	0.35 - 1.00 (8.9 - 25.3)
Lock-nut Hex Size	mm	24	24	24	30	30	30
Lock-nut Tightening Torque	lbf-ft (Nm)	94 (128)	94 (128)	94 (128)	173 (235)	173 (235)	173 (235)

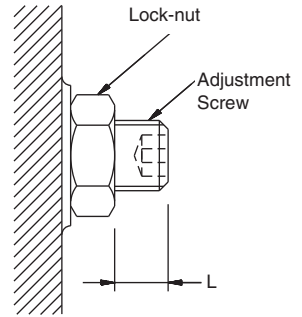

Pressure Cut-off or Load Sense (P0/L0) Control Regulator

P0/L0 Regulator Adjustment	Unit	K3VL45/60/80	K3VL112/140/200
Cut-off/Load Sense Adjustment Screws: Internal Hex Size	mm	4	4
Cut-off Pressure Change Per Screw Revolution ¹	psi (bar)	580 (40)	1330 (92)
Differential Pressure Change Per Screw Revolution ¹	psi (bar)	188 (13)	80 (5.5)
Cut-off/Load Sense Adjustment Screws: Lock-nut Hex Size	mm	8	8
Lock-nut Tightening Torque	lbf-ft (Nm)	12 (16)	12 (16)

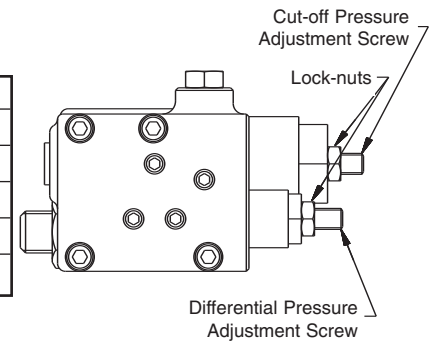

¹ Turning the adjustment screw clockwise increases the setting.

Torque Limit Control Module

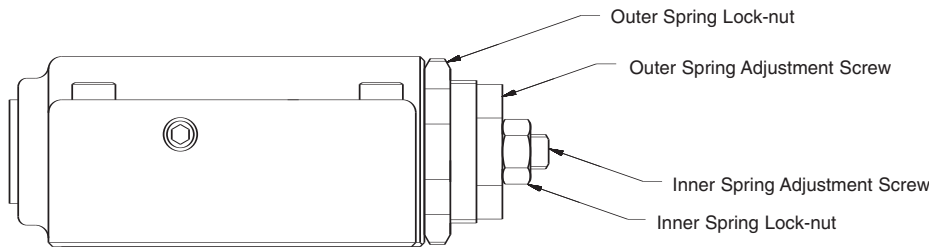

Torque Limit P-Q Curve

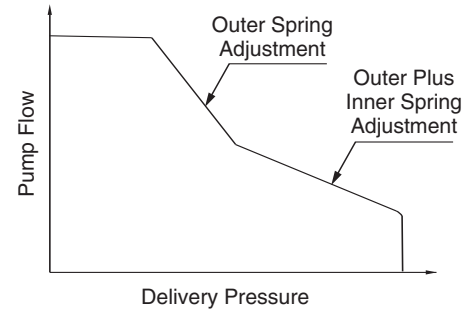

Torque Limit Control Module Adjustments

Outer Spring Adjustment Screws: External Hex Size	mm	27
Outer Spring Lock-nut Size	mm	41
Outer Spring Lock-nut Tightening Torque	lbf-ft (Nm)	75 (102)
Inner Spring Adjustment Screw: Internal Hex Size	mm	4
Inner Spring Lock-nut Size	mm	13
Inner Spring Lock-nut Tightening Torque	lbf-ft (Nm)	12 (16)

15.0 Integral Unloading Valve, Proportional Unloading Valve, Electronic Displacement Control

Installation Dimensions

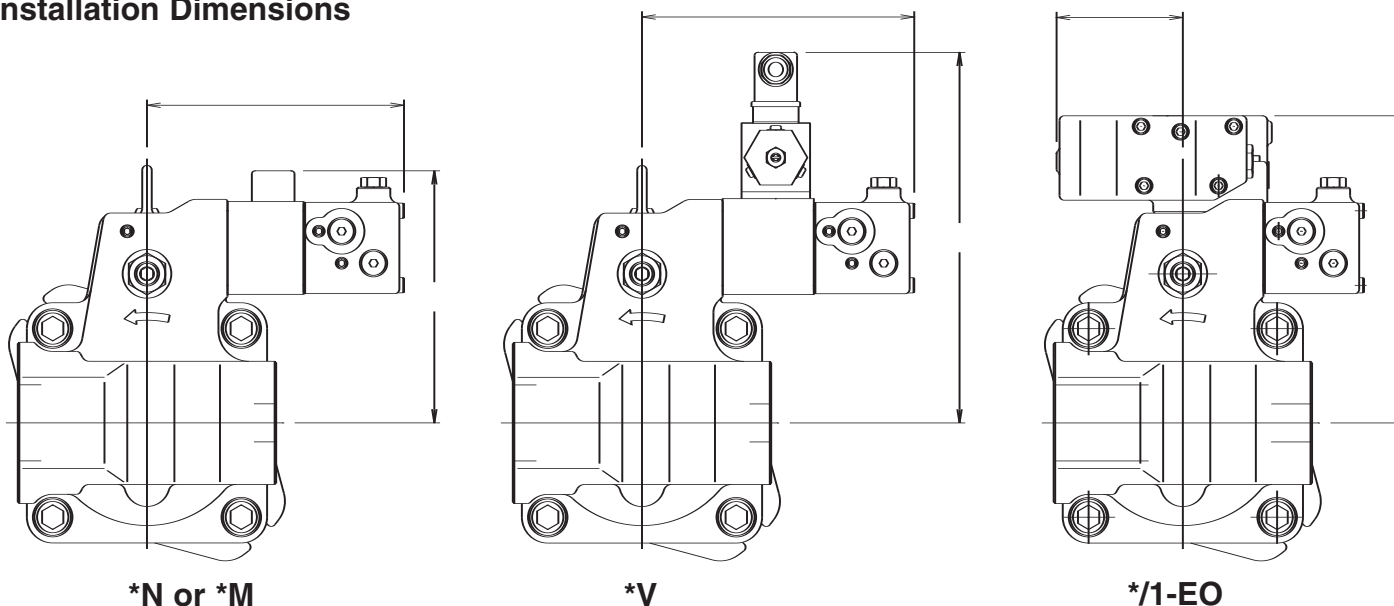

Unloading Valve - *N or *M

	A	B
K3VL45/60	6.65 (169)	6.10 (155)
K3VL80	6.65 (169)	6.54 (166)
K3VL112/140	7.95 (202)	7.48 (190)
K3VL200	8.35 (212)	8.07 (205)

*1Proportional Relief Valve - *V

	A	B
K3VL45	6.65 (169)	9.17 (233)
K3VL80	6.65 (169)	9.61 (244)
K3VL112/140	7.95 (202)	11.02 (280)
K3VL200	8.35 (212)	11.61 (295)

*1Electronic Displacement Control - 1/EO

	A	B	Psv - Supply Pressure Port for EO Control
K3VL45/60	3.54 (90)	7.36 (187)	"S" Type: 3/8" O-ring Boss – SAE J1926/1 (9/16-18UNF-2B)
K3VL80	3.27 (83)	7.95 (202)	"S" Type: 3/8" O-ring Boss – SAE J1926/1 (9/16-18UNF-2B)
K3VL112/140	3.07 (78)	9.61 (244)	"S" Type: 3/8" O-ring Boss – SAE J1926/1 (9/16-18UNF-2B)
K3VL200	3.23 (82)	10.20 (259)	"S" Type: 3/8" O-ring Boss – SAE J1926/1 (9/16-18UNF-2B)

Solenoid Data: Unloading Valve - *N or *M

Solenoid Voltage	115VAC	230VAC	6VDC	12VDC	24VDC
Connector Type	ISO4400 / DIN 43650				
Solenoid Resistance at 72°F (22°C)	551Ω	2010Ω	3.5Ω	12.8Ω	45.8Ω
Holding Current at 122°F (50°C)	0.18A	0.09A	1.71A	0.94A	0.52A
Power Consumption	21VA		12W		
Relative Duty Factor	100%				
Response Time at Rated Voltage	30mS				
Protection	IEC144 / DIN 40050 Class IP65				

*1 See Section 16: KC-B10-11 Amplifier for solenoid data.

16.0 KC-B10-11 Proportional Amplifier

Specifications

Current Control Pulse Width Modulation	50 ~ 250Hz adjustable
Supply Input Voltage	24VDC +/-20%
Command Input Signal Voltage	0 ~ 5VDC, Max 7.5VDC
Rated Output Current	0.8A (at 5VDC signal input)
Maximum Output Current	1.2A
Power Consumption	Maximum 20VA
Load Resistance	14 ~ 21Ω
Input Impedance	100KΩ
Ambient Temperature Range	32 ~ 122° F (0 ~ 50°C)
Maximum Humidity	90% RH (No dew permissible)
Vibration Resistance (JIS C50250 Type A)	Amplitude: 0.59 in peak to peak (1.5 mm peak to peak) Frequency: 10 ~ 55 Hz
Insulation	100MW minimum at 500VDC
Current Monitor Output	0.47V/A
Mass	0.041lb (90g)
Gain Adjustment Range	0.8A +/- 0.2A at 5VDC input
Bias Adjustment Range	0 ~ 0.24A
Ramp Time Adjustment Range	(0.1 ~ 5 sec for ramp up from 0 ~ 0.8A) (0.1 ~ 5 sec for ramp down from 0.8A ~ 0)
Linearity	Up to 2% FS
Current Stability	Up to 1.5% FS (ambient temperature change 122°F (50°C)) Up to 2% FS (for supply voltage change +/-20%) Up to 2% FS (load resistance change 14 ~ 21Ω)
Supply Fuse	3.2A Anti-surge plug type PCB mounted

Installation Drawing

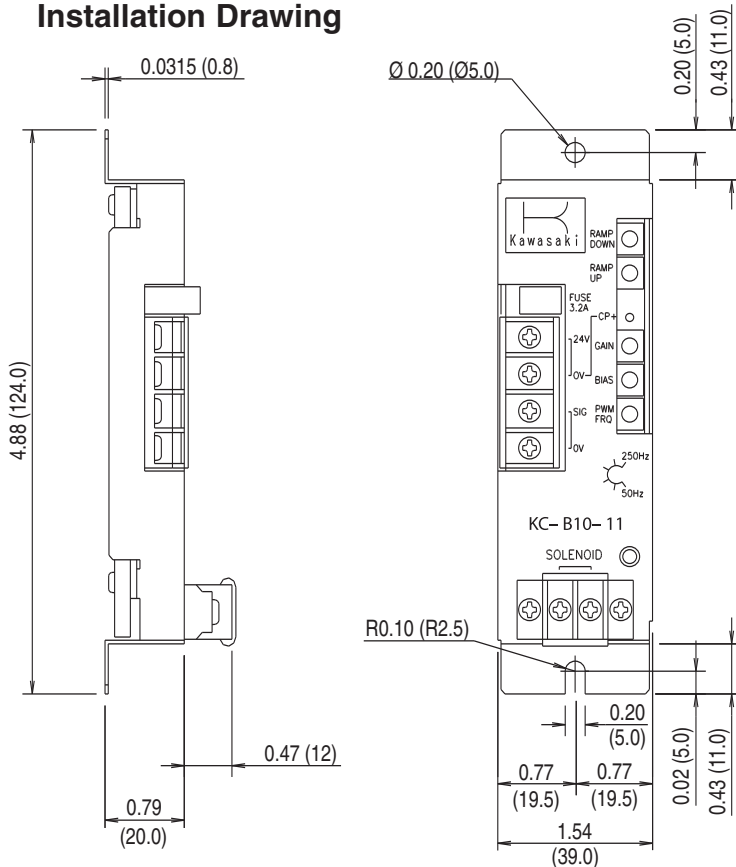

Kawasaki Precision Machinery (U.S.A.), Inc.
 5080 36th Street S.E., Grand Rapids, MI 49512
 (616) 949-6500 • Fax (616) 975-3103

www.kpm-usa.com