

Variable displacement axial piston pump type V30E

InLine

Pressure p_{\max} = 420 bar (6000 psi)
Displacement V_{\max} = 270 ccm/rev

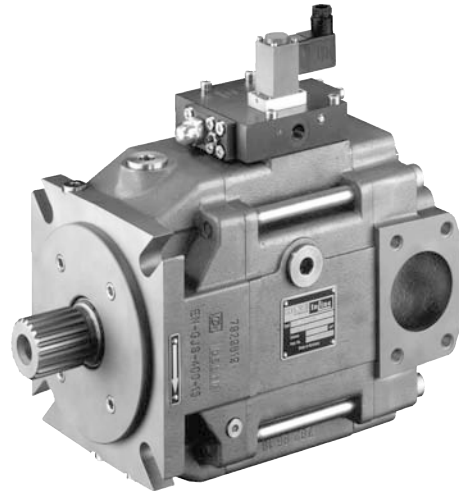
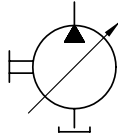

1. General description

The axial piston variable displacement pumps of the type V 30 of E offer extremely high function safety. Its remarkably low noise levels, the high pressure rating (peak = 420 bar / perm. = 350 bar), the low weight/performance ratio as well as the wide controller range make it possible to employ it for most industrial and mobile applications. The variable displacement pumps work according to the swash plate principle: 9 pistons operate in a rotating cylinder cavities where they fulfill one suction and one pressure stroke per rotation.

Opening and closing of the cylinder cavities is via openings in the control disc. The axial movement of the pistons is provided by an adjustable swash plate. The setting angle (0 - max) can be steplessly varied in proportion to the desired displacement/flow. The setting range can be mechanically limited by setting screws. The position of the swash plate can be controlled via a visual mechanical indicator.

The latest knowledge and experience with regard to noise reduction has been used in the development of this pump design. V30E is therefore rather quiet, even when taken to the limit. All components used in the V30E are manufactured from high grade materials and machined with close tolerances.

The wide range of modular controllers along with a thru-shaft (option for mounting auxiliary pumps or a second V30D) open up a wide range of application possibilities.

Therefore type V30E features a pump design, which ideally suits the special requirements of modern industrial and mobile hydraulic drive systems

Low dead weight and high self-priming speed in combination long service life and low noise level are the highlights of this pump design.

Main features:

- Low specific weight
- Very fast response times due to low mass moment of inertia of the setting unit
- The short stroke design enhances the extremely high self priming speed
- Prolonged service life because of
 - high pressure lubed swash plate bearing
 - hydro-statically relieved steel followers with bronze sliding face
 - generously dimensioned shaft bearings

Main benefits

- Low noise level and low flow/pressure-pulsation led to low noise emission.
- Controller assemblies have been designed on a modular basis and can be installed without dismantling the basic pump
- Thru-shaft allows tandem pump combinations and mounting of auxiliary pumps of all kinds (see sect. 5)
- Swash-plate dial indicator and swash-plate angle transducer provide important function monitoring
- High self-priming speed
- Long service life due to special design of followers, swash plate bearing and control disc

2. Available versions, main data

Calculation:

Flow rate

$$Q = \frac{V_g \cdot n \cdot \eta_v}{1000} \text{ (l/min)}$$

Torque

$$M = \frac{1,59 \cdot V_g \cdot \Delta p}{100 \cdot \eta_{mh}} \text{ (Nm)}$$

Power

$$P = \frac{2\pi \cdot M \cdot n}{60000} = \frac{M \cdot n}{9549} = \frac{Q \cdot \Delta p}{600 \cdot \eta_t} \text{ (kW)}$$

V_g = Displacement [ccm/rev]
 Δp = Diff. pressure [bar]
 n = Speed [rpm]

η_v = Volumetric efficiency
 η_{mh} = Mechanical efficiency
 η_t = Total efficiency ($\eta_t = \eta_v \times \eta_{mh}$)

Order example:

V30E - 095 R K N - 2 - 1 - XX/LN /120 - 200 - SAE-A - Z 05

Basic type

Table 1: Designation

Coding	095	160	270
Displacement ccm/rev. (cu. in./rev.)	98	160	270
Flow (theor.) at 1450 rpm [lpm] (1800 rpm [gpm])	142 (46.5)	232 (76.0)	392 (128)
Max. continuous pressure bar (psi)	350 (5100)	350 (5100)	350 (5100)
Max. peak pressure bar (psi)	420 (6100)	420 (6100)	420 (6100)
Max. housing pressure bar (psi)	1.0	1.0	1.0

Direction of rotation:

L = Left hand
R = Right hand
 (facing the drive shaft)

Controller see table 2 below

2. Pump (see sect. 5)

Pressure (bar)
 Specification only apparent with pressure controllers type N, LSN

Torque setting in Nm alternative power in kW and speed in rpm as additional text
 Specification only apparent with torque controllers type L

HAWE serial no.

Swash angle indicator:

0 = without indicator
1 = with indicator
2 = with swash-plate angle transducer (Hall-sensor)

Shaft design:

1 = No thru-shaft
2 = Thru-shaft (see also sect. 5)

Shaft seals:

N = NBR
E = EPDM
V = FKM

Shaft:

D = Spline shaft (DIN 5480)
K = Key shaft
S = Spline shaft and flange SAE

Table 2: Controller

Type	Description		
N - ...	Pressure controller, adjustable directly at the pump, plus as port for external pilot valve. Pressure controller automatically maintains a constant system pressure independant of the required flow. Therefore it is suited for constant pressure systems, where differing flow is required or as efficient pressure limitation of the hydraulic system.		
LSN - ...	Load-Sensing-Controller with pressure limitation. Stand-by pressure, adjustable between 15 ... 35 bar; pre-set at HAWE: 25 bar +5 bar		
-PMVP 4- 41 /G 12 42 /G 24 43	<table border="1"> <tr> <td>Pressure range (5) ... 180 bar (5) ... 290 bar (5) ... 440 bar</td> <td>Additional, directly mounted prop. pressure limiting valve as reference setting for the pressure controller (nom. voltage 12V DC or 24V DC plus specification of the desired pressure range). This prop. pressure limiting valve is compatible to all controllers listed here. Type PMVP 4 acc. to D 7485/1 is utilized here. Retrofitting is possible anytime. Order example: V30E-095 RSN - 1 - 00 / N - PMVP 4 - 43 / G 24 - 350</td> </tr> </table> <p>Solenoid voltage</p>	Pressure range (5) ... 180 bar (5) ... 290 bar (5) ... 440 bar	Additional, directly mounted prop. pressure limiting valve as reference setting for the pressure controller (nom. voltage 12V DC or 24V DC plus specification of the desired pressure range). This prop. pressure limiting valve is compatible to all controllers listed here. Type PMVP 4 acc. to D 7485/1 is utilized here. Retrofitting is possible anytime. Order example: V30E-095 RSN - 1 - 00 / N - PMVP 4 - 43 / G 24 - 350
Pressure range (5) ... 180 bar (5) ... 290 bar (5) ... 440 bar	Additional, directly mounted prop. pressure limiting valve as reference setting for the pressure controller (nom. voltage 12V DC or 24V DC plus specification of the desired pressure range). This prop. pressure limiting valve is compatible to all controllers listed here. Type PMVP 4 acc. to D 7485/1 is utilized here. Retrofitting is possible anytime. Order example: V30E-095 RSN - 1 - 00 / N - PMVP 4 - 43 / G 24 - 350		
Intermediate plates			
EM.CH	<p>The electro-hydraulic pump adjustment adjusts the geom. displacement of the pump from "zero" to "max" - proportional to the electrical control signal (0...10 V or 0...20 mA). The energy necessary for the adjustment is taken from the high pressure line. An auxiliary pump is required when the system pressure drops below 50 bar. Suited auxiliary pump acc. to 5.2</p> <p>V30E-095: Z05 V30E-160: Z08 V30E-270: Z10</p> <p>The control system consists out of the mechanical displacement control of the pump, a prop. directional control valve size NG 6 and the swash-plate angle transducer (Hall-sensor, coding 2) recording the current state. The control electronics (coding CH, type DAC-4, Co. HCS) compares set point and actual value and supplies the respective current to the valve solenoids. The utilized electronics allows customized tuning via ramps, retrieval of set points, pressure or power limitation etc. .</p> <p>Attention : The response time is about 200 ms.</p> <p>When pressure and/or power limitation is requested a combination with a pressure controller (coding N), Load-Sensing controller (coding LSN) and/or torque controller (coding L) is possible.</p> <p>Attention: Not suitable for highly dynamic processes! The response time is about 200 ms. When pressure and/or power limitation is requested a combination with a pressure controller (coding N, Load-Sensing controller (coding LSN) and/or torque controller (coding L) is possible.</p> <p>Order example: V30E-095 RKN - 2 - 2-00 / EMNCH - 250 - SAE-A - Z 05 V30E-270 RSN - 2 - 2-00 / EMLNCH / 1800 - 350 - SAE-A - Z 10 V30E-160 RDN - 2 - 2-00 / EMOCH - SAE-A - Z 08 (Version without pressure limitation)</p>		
L .	<p>The torque controller with hyperbolic characteristic is suited best for application where the pressure is varying heavily and the motor has to be protected against overload. Due to the controller design, the drive torque is limited in such a way that the product "pressure x delivery flow" is kept constant, i.e. doubled pressure will cause the delivery flow to be halved automatically. The max drive torque can be adjusted from outside via a set-screw.</p> <p>Order example: V30E-160 RKN - 0 - 1 - 00 / LN / 180 - 300 V30E-095 RSN - 1 - 1 - 00 / LLSN / 120 - 200 - SAE-A</p>		

Symbols

Variable displacement axial piston pump with controller

Coding **N**

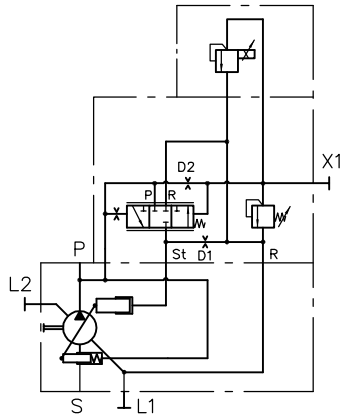

Coding **LSN**

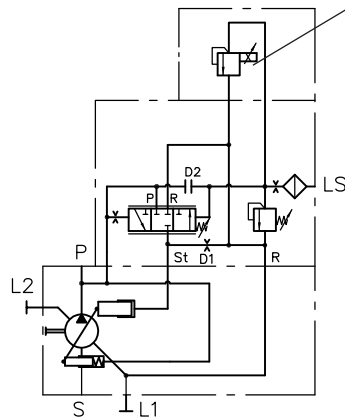

Option:
Prop. pressure
limiting valve
type PMVP 4..
acc. to D 7485/1

Coding **LN**

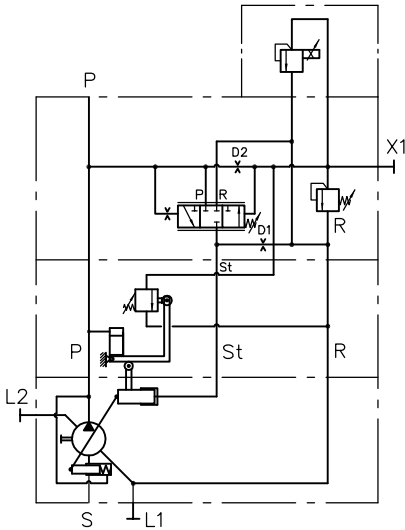

Coding **LLSN**

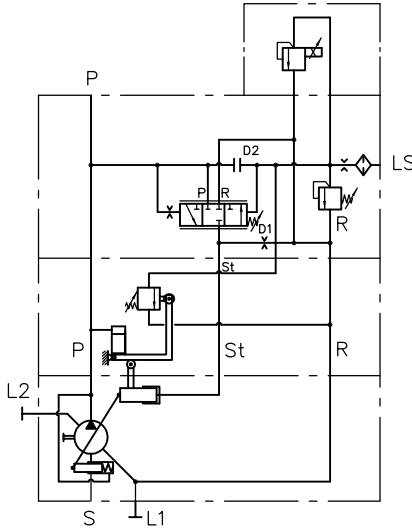

Coding **EM0CH**

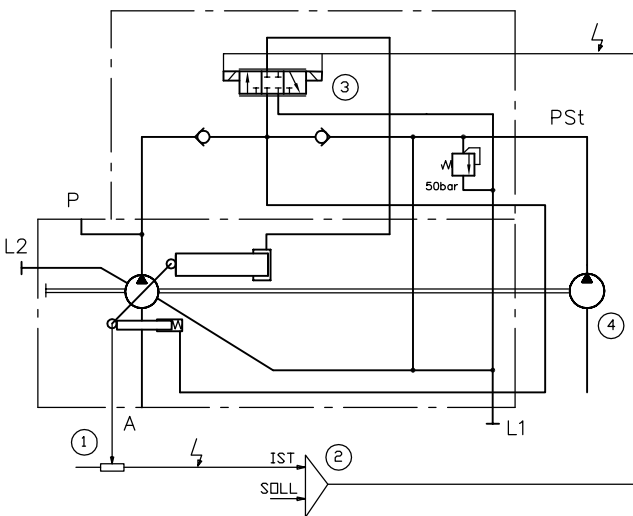

- S - Suction port
- P - Pressure port
- (L1) (L2) - Drain port
- X1 - Remote control port (additional pilot valves)
- LS - Load pressure port (Load Sensing-Pressure, picked up after the metering throttle at the main circuit)
- X2 - External system pressure port
- D1 - Dampening throttle
- D2 - Piloting throttle (o plugged)

- ① Swash-plate angle pick-up
- ② Amplifier card
- ③ Prop. directional valve
- ④ Auxiliary pump

Coding **EMNCH**

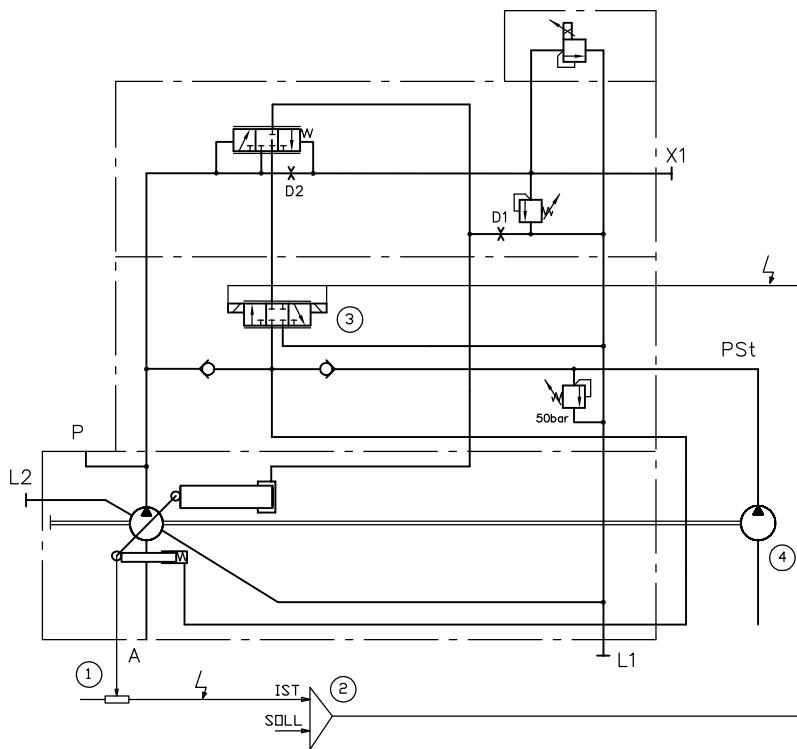

- ① Swash-plate angle pick-up
- ② Amplifier card
- ③ Prop. directional valve
- ④ Auxiliary pump

Coding **EMLNCH**

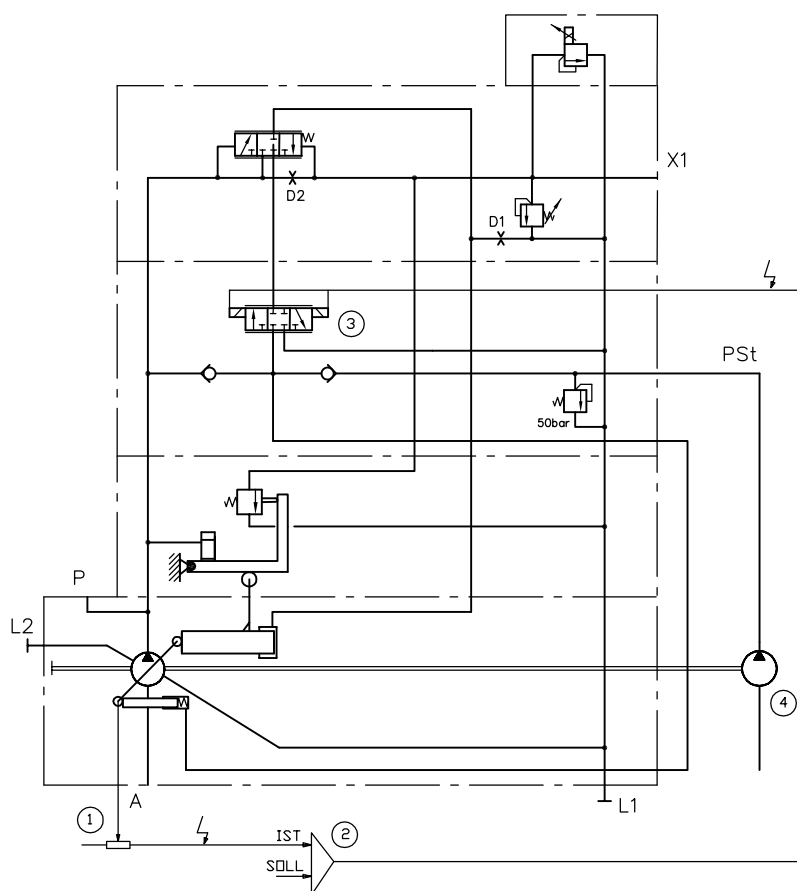

3. Additional versions

3.1 General

Working principle	Variable displacement axial piston pump acc. to swash plate principle
Installation	Flange or bracket mounting
Direction of rotation	Right hand or left hand
Mounting position	Optional / Observe the instructions for installation in B 7960!
Pressure fluid	Hydraulic fluid (DIN 51524 table 2 and 3); ISO VG 10 to 68 (DIN 51519) Viscosity range: min. 10; max. 1000 mm ² /sec, optimal operation range: 16 ... 35 mm ² /sec Also suitable are biodegradable pressure fluids of the type HEES (synth. Ester) at operation temperatures up to +70°C.
Temperatur	Ambient: -40 ... +60°C Fluid: -25 ... +80°C, pay attention to the viscosity range! Start temperature down to -40°C are allowable (Pay attention to the viscosity range during start!), as long as the operation temperature during consequent running is at least 20K (Kelvin) higher.
Filtration	Should conform to ISO standard 4406 coding 18/13.
Start-up	All hydraulic lines should be flushed with appropriate hydraulic fluid before start-up. The pump case should then be tilted through the uppermost drain port. The drain line must be positioned so that the case is always filled during operation. At start-up and during the first few minutes of the operation the pressure relief valve should be adjusted to 50 bar (700 psi) or less.

Designation		095	160	270
Max. swash plate angle	(°)	15	15	15
Min. inlet pressure (absolute) open circuit	(bar)	0.85	0.85	0.85
Self-priming at max. swash plate angle and 1 bar (15 psi) absolute inlet pressure	(rpm)	2500	2100	1900
Max. speed (requires increased inlet pressure)	(rpm)	2900	2500	2000
Min. continuous speed	(rpm)	500	500	500
Torque (theor.) at 100 bar (1450 psi)	(Nm) (lbf ft)	156	255	430
Input power at 250 bar and 1450 rpm (50 Hz) at 3000 psi and 1800 rpm (60 Hz)	(kW)	66	107	177
Weight (approx. kg)	without controller	54	74	126
Controller	LSN, N, NB	+ 2.5	+ 2.5	+ 2.5
	PMVP 4	+ 1.1	+ 1.1	+ 1.1
	L	+ 2.5	+ 2.5	+ 2.5
	EM	+ 6.1	+ 6.1	+ 6.1
Moment of inertia of the rotary assembly	(kg m ²)	0.022	0.03	0.035
Lh bearing life at max. displacement and at 250 bar and 1450 rpm (50 Hz) at 3000 psi and 1800 rpm (60 Hz) max. displacement	(h) ²⁾	20000	19000	20000
Max. dynamic torque				
Spline shaft (D) - input	(Nm)	1200	1700	3400
Spline shaft (D) - output	(Nm)	600	850	1700
Key shaft (K) - input	(Nm)	650	850	1700
Spline shaft (S) - input	(Nm)	1200	1200	1200
Spline shaft (S) - output 1)	(Nm)	600	850	1200
Noise level at 250 bar and (1450 rpm), displacement (measured in a semi-anechoic room according to ISO 4412 measuring distance 1m)	(dB(A))	73	74	78

1) Drive torque must not be exceeded!

2) Lh = (theoretical) service life for 90% of the bearings

3.2 Curves

3.2.1 Flow and Power (basic pump)

The curves show delivery flow/pressure(without controller). Drive power at max. swash-plate angle and drive power at idle stroke and 1500 rpm

Type V30E-095

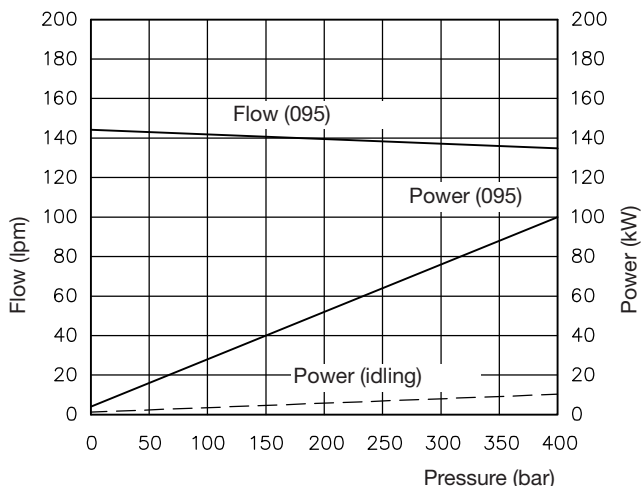

Type V30E-160

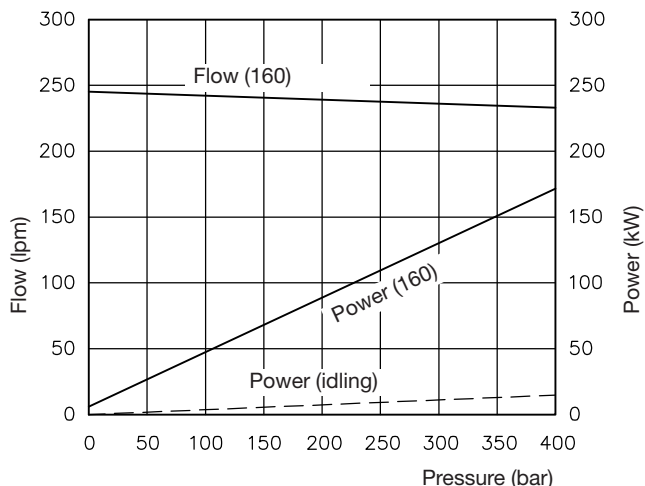

Type V30E-270

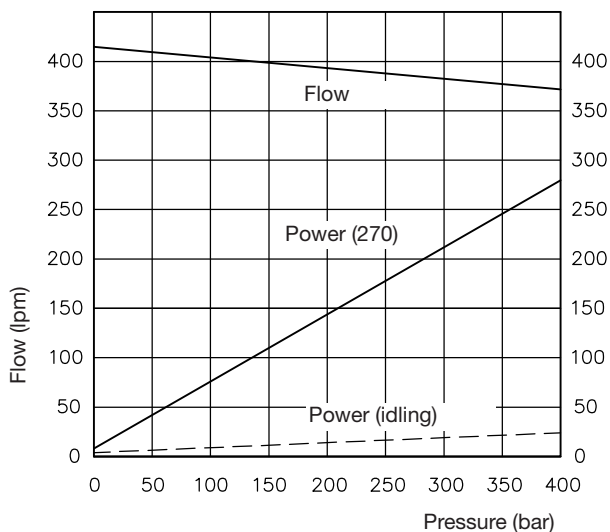

Inlet pressure and self-suction speed

The curves apply to viscosity of 75 mm²/s at max. swash-plate angle

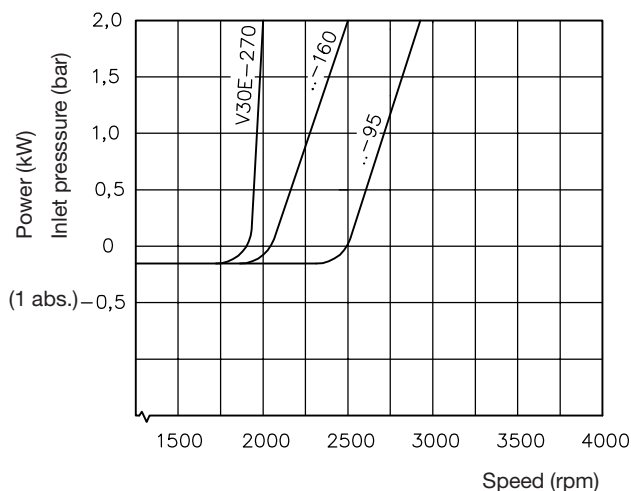

3.2.2 Swash-plate angle transducer

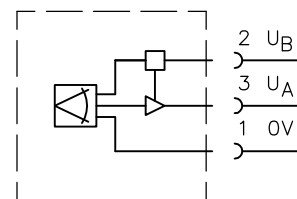
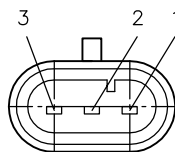
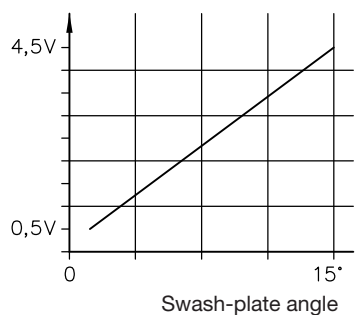

U_B = 10...30 V DC
 U_A = 0.5...4.5 V
 EMV - approved for automotive applications DIN 40839 test impulse 1, 2, 3a/b
 Field radiation 200 V/m
 Circuitry 3-PIN AMP Superseal 1.5 plug

3.2.3 Controller-curves

Coding | Curves, notes

N

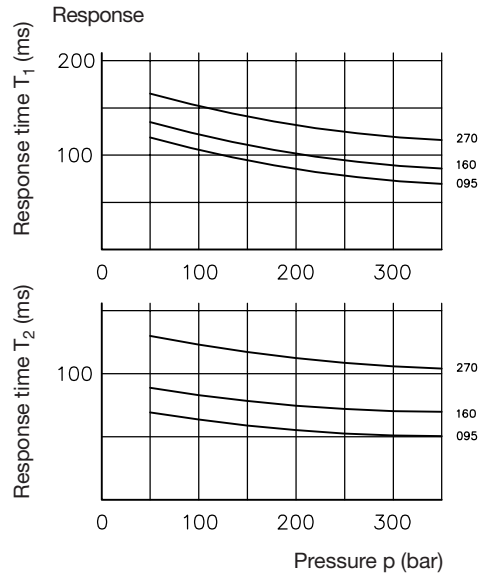
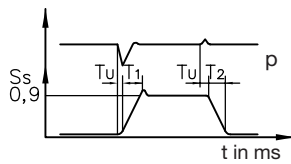
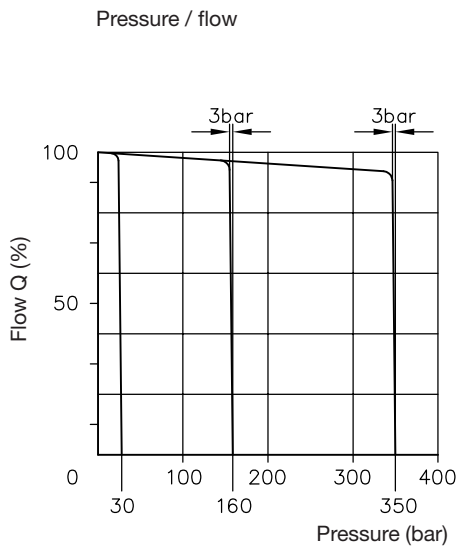

S_s = Displacement
 T_u = Delay < 3 ms
 T₁ = Response time min to max
 T₂ = Response time max to min
 p = Pressure for hydraulic capacity 0.15 cm³/bar (1.5 m pipe nom. dia. 20 mm)

LSN

Speed constant

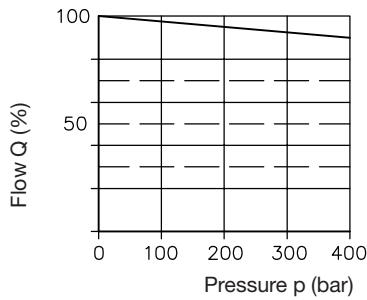

Calculation of flow Q:

$$Q = C \cdot A \cdot \sqrt{\Delta p} \text{ (lpm)}$$

A = Size of orifice (mm²)
 Δp = Pressure drop = 10 bar (LS = 30 bar) = 145 psi (LS = 435 psi)
 C = 0.6

Speed varying

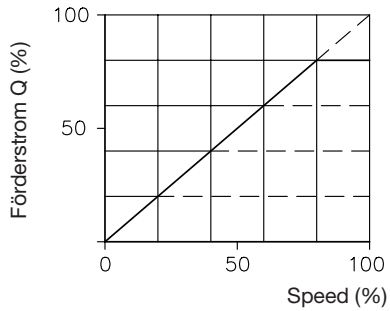

Characteristics:

Accuracy with max. flow:

- a) Speed "n" constant, pressure varying between 30 and 350 bar, (430 and 3600 psi): (< 3%)
- b) Pressure "p" constant, speed varying (< 1%)

Coding | Curves, notes

L

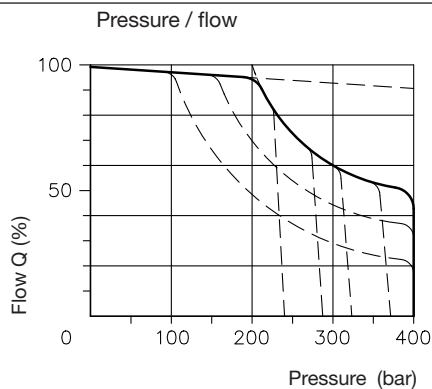

Lowest recommended torque setting

Coding	Nm (lb ft)	corresponds to kW / rpm
095	99	15 / 1500
160	146	22 / 1500
270	300	45 / 1500

EM..CH

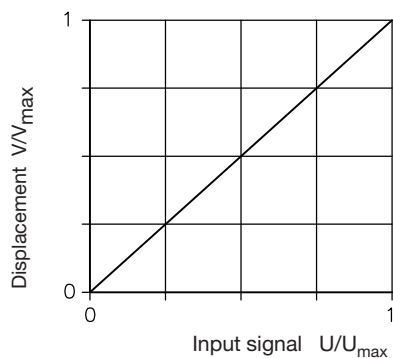

Response time, upwards 270 ms...180 ms
 Response time, downwards 130 ms...100 ms
 Hysteresis and linearity 1 %

Components
 Amplifier and controller card

Type DAC-4,
 Co. HCS,
 D-72636 Frickenhausen,
www.h-c-s-gmbh.de
 18 ...30 VDC, residual ripple < 10 %
 0 ...10 V, 0 ... 20 mA
 Type D 1FBE 01 HC 0 NW 0

- Power supply
 - Set point input
 Prop. directional valve

4. Unit dimensions All dimensions in mm, (inch) and subject to change without notice!

4.1 Basic pump

Type V30E-095 (Drawings shows clockwise rotation, ports A and B are located different with anti clockwise rotation, see foot note 1))

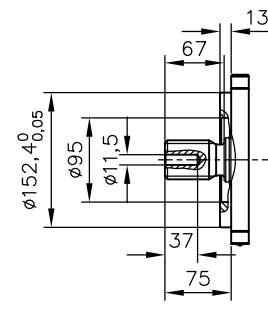
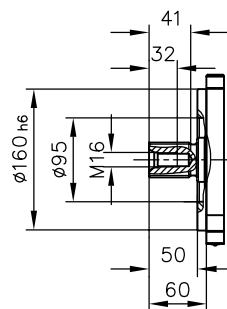
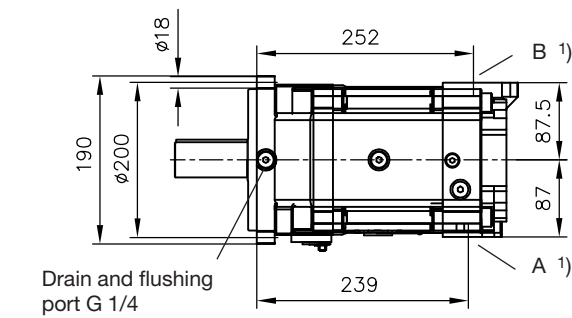

Coding D:
Spline shaft
W45x2x21x9g
DIN 5480

Coding S:
Spline shaft SAE-D13T - 8/16 DP
Flat Root Side Fit
For flange dimensions,
see page 14

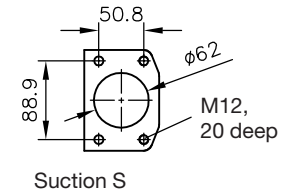
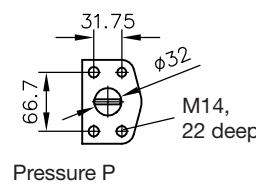
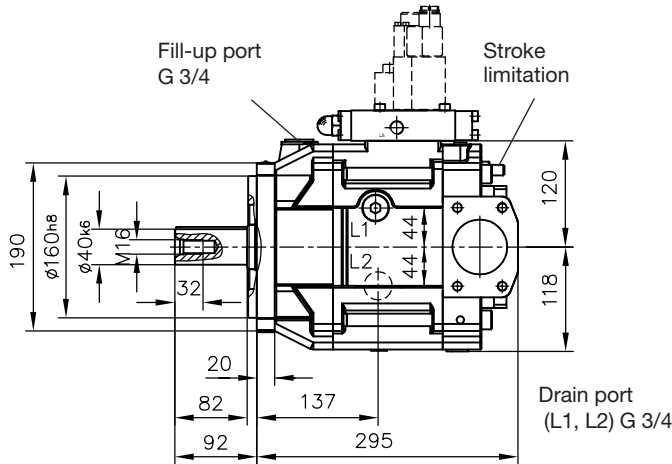

Type V30E-160 (Drawings shows clockwise rotation, ports A and B are located different with anti clockwise rotation, see foot note 1))

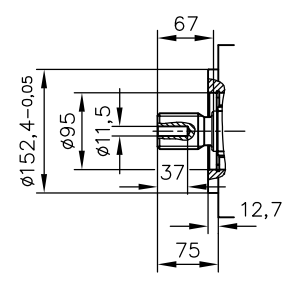
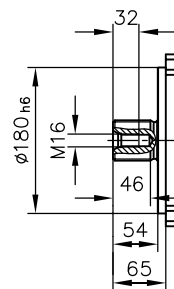
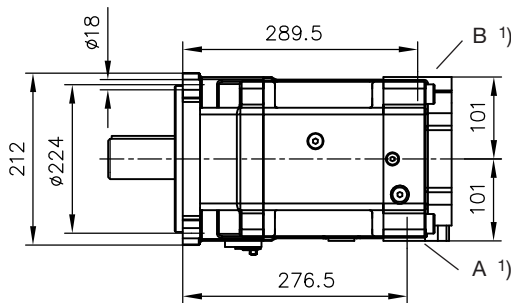

Coding D:
Spline shaft
W50x2x24x9g
DIN 5480

Coding S:
Spline shaft SAE-D13T - 8/16 DP
Flat Root Side Fit
For flange dimensions,
see page 14

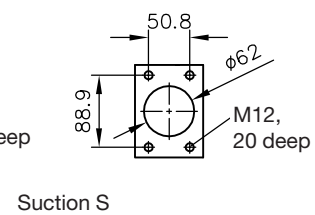
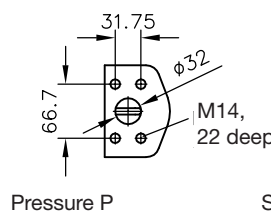
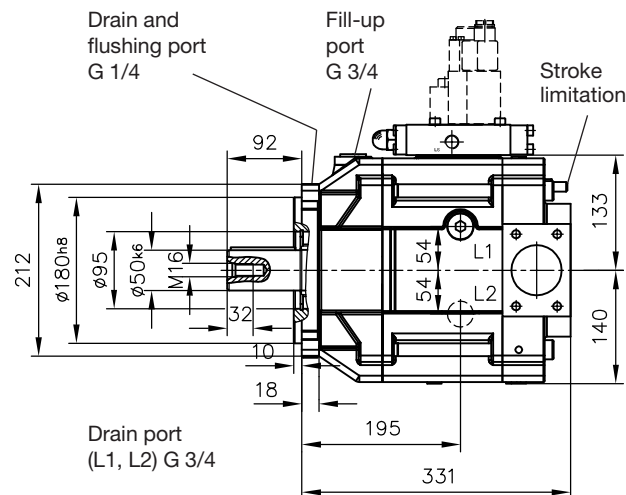

- 1) With right-hand rotation:
B= Suction S = SAE 2 1/2" (3000 psi)
A= Pressure P = SAE 1 1/4" (6000 psi)
- Anti clockwise rotation:
B = Pressure P = SAE 1 1/4" (6000 psi)
A = Suction S = SAE 2 1/2" (3000 psi)

Type V30E-270 (Drawings shows clockwise rotation, ports A and B are located different with anti clockwise rotation, see foot note 1))

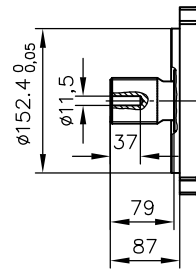
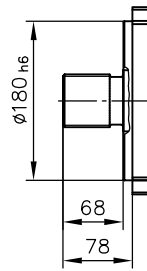
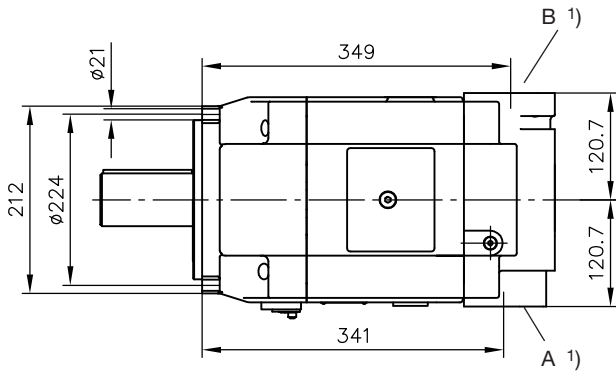

Coding D
Spline shaft W60x2x28x8g
DIN 5480

Coding S
Spline shaft SAE-D13T 8/16DP
Flat Root Side Fit
For flange dimensions,
see page 14

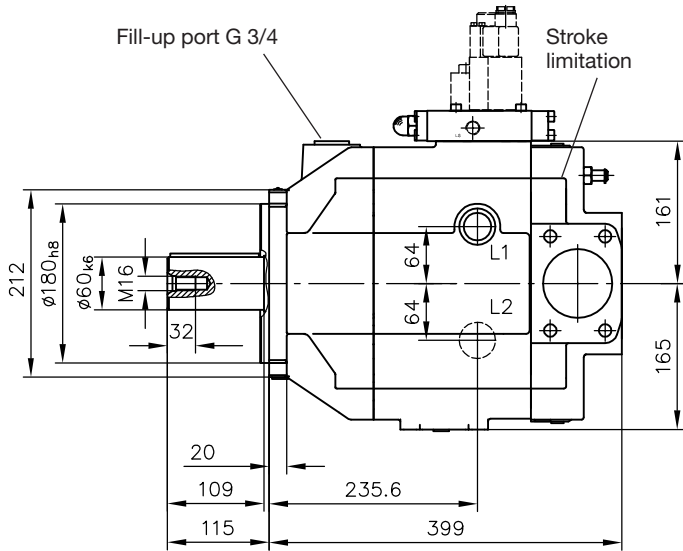

Drain port
(L1, L2) G 3/4

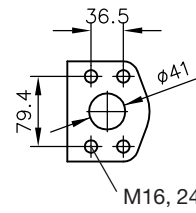

Pressure P

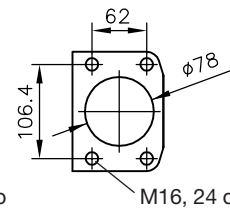

Suction S

1) With right-hand rotation:

B = Suction S = SAE 3" (3000 psi)
A = Pressure P = SAE 1 1/2" (6000 psi)

Anti clockwise rotation:

B = Pressure P = SAE 1 1/2" (6000 psi)
A = Suction S = SAE 3" (3000 psi)

Swivel plate angle indicator

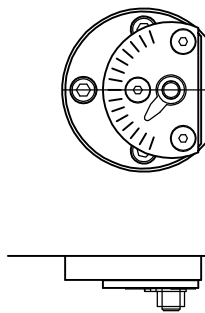

Swivel plate angle transducer

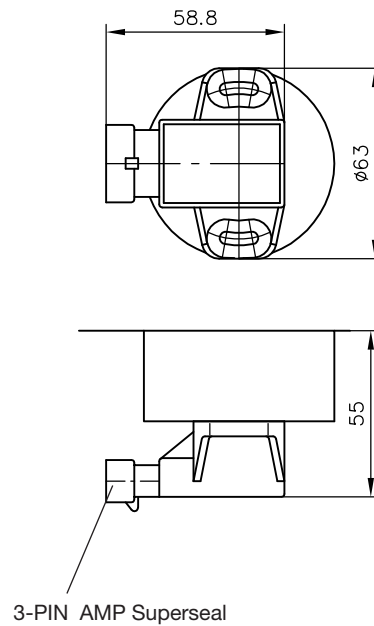

4.2 Controller

Codings **N**, **Nb**, and **LSN**

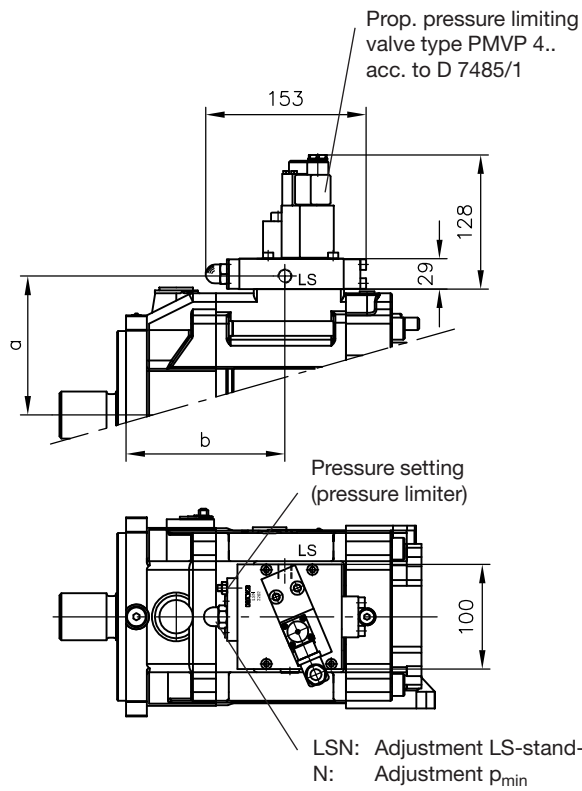

Codings **LN** and **LLSN**

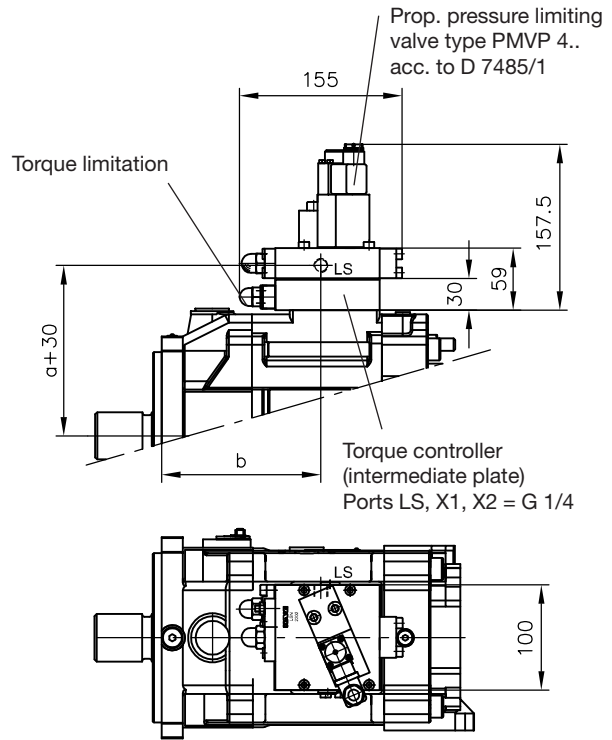

Codings **EM...**
EML...

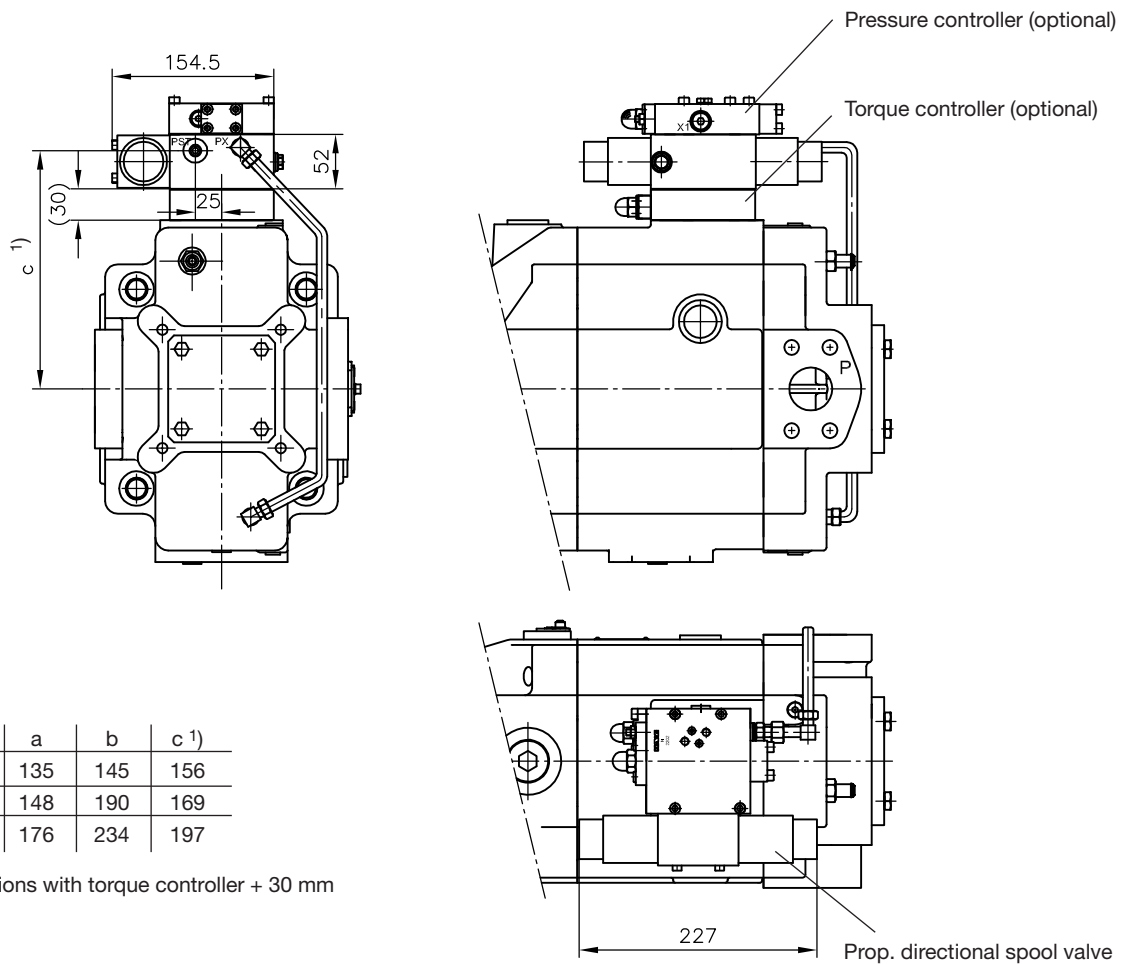

	a	b	c 1)
V30E-095	135	145	156
V30E-160	148	190	169
V30E-270	176	234	197

1) For versions with torque controller + 30 mm

5. Pump combinations

5.1 Tandem pumps

Two variable displacement axial piston pumps can be linked via an intermediate flange. The drive shafts are sufficiently dimensioned to run even the second pump also at max. torque.

Same controller range as for individual pumps.

Available shaft designs: "D" and "S".

Order example: V30E-160 RKN-2-1-XX / LLSN /120 - 200 - V30E-160 RKN-1-1-XX / LLSN /120 - 200
 (1. pump) (2. pump)

(For type coding key, see sect. 2)

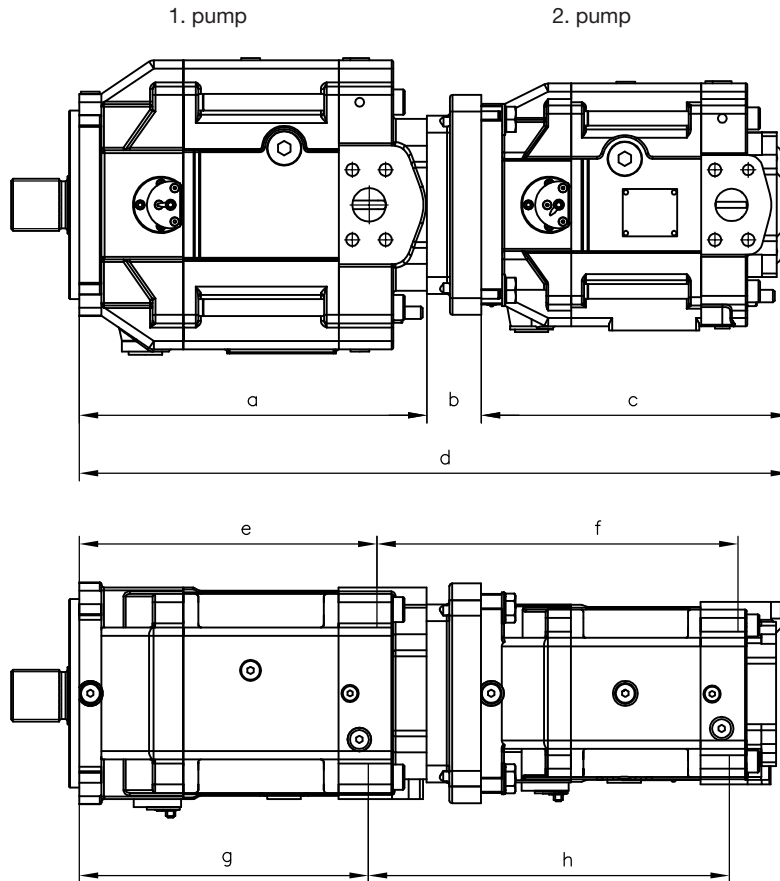

1. pump \ 2. pump	V30E-095							
	a	b	c	d	e	f	g	h
V30E-095	336	63	341	740	296	399	300	399
	V30E-160							
	a	b	c	d	e	f	g	h
V30E-095	358	63	341	762	317	400	323	398
V30E-160	358	84	363	805	317	442	323	442
	V30E-270							
	a	b	c	d	e	f	g	h
V30E-095	415	75	341	831	366	420	372	418
V30E-160	415	87	363	865	366	453	372	453
V30E-270	415	87	431	933	366	502	372	502

5.2 Combination with gear pump

A directly mounted auxiliary or additional gear pump is available. All pipe work is fitted when a pump with electro-hydraulic prop. adjustment together with directly mounted auxiliary pump is ordered.

Order example:

V30E-160 RKN 2 -1 - XX / LSN / 280 - **SAE-A - Z 05**



Coding	Delivery flow V_g (cm ³ /rev ²)	Auxiliary pump for 1)	G	G1	c 2)	k 2)
Z 05	5	V30E-095	G 3/8	G 3/8	77	68
Z 08	8	V30E-160	G 3/8	G 3/8	87	68
Z 10	10	V30E-270	G 3/8	G 3/8	98	89

Basic pump V30E

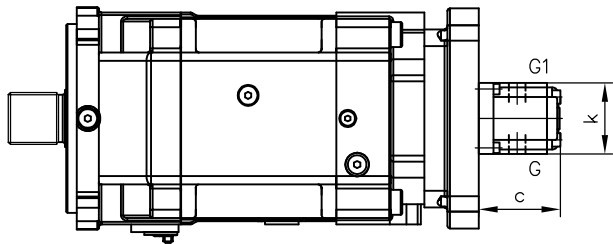
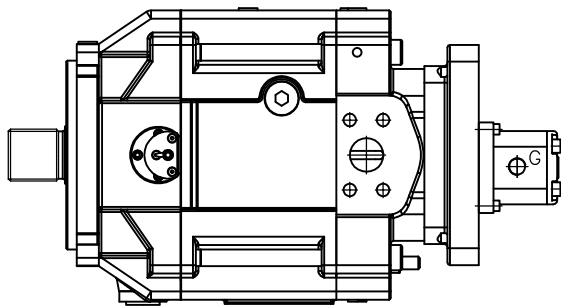

- 1) Is required as auxiliary pump for electro-hydraulic prop. adjustment
- 2) Guideline

5.3 Additional combinations

Additional combinations are possible via the SAE-flange.

Order example: V30E-160 RSN -2-1-XX / LN /120 - 200 - **SAE-C/4**

Possible combinations and dimensions
(flange height (b) like in sect. 5.1)

Flange
SAE-A SAE-B/2

Flange
SAE-C/4 SAE-D 1)

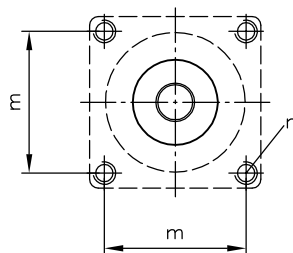
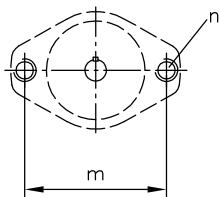

1) Notes to version with shaft end coding **S**:
The SAE-flanges on the drive side feature thru-holes instead of threads n

	SAE-A	SAE-B/2	SAE-C/4	SAE-D
V30E-095	18	30	42	52
V30E-160	18	30	42	52
V30E-270	18	30	42	52
Dimension m	106.4	146	114.5	161.9
n	2xM10	2xM12	4xM12	4xM16