

# Proportional directional spool valve type PSLF, PSVF, and SLF according to the Load-Sensing principle size 3 and 5 (manifold mounting)

## 1. General information

The directional spool valves types PSLF and PSVF as well as the individual sections type SLF serve to control both, the direction of movement and the load-independent, stepless velocity of the hydraulic consumers. In this way several consumers may be moved simultaneously, independently from each other at different velocity and pressure ratings, as long as the sum of the partial flows needed for this is within the total delivery supplied by the pump.

The proportional spool valves of this pamphlet are designed as manifold mounting valves. They may be also combined as valve banks via the sub-plates available from HAWE.

They consist of three functional groups:

### Basic data

|                              |   |
|------------------------------|---|
| Design                       | Prop. directional spool valve according to the Load-Sensing principle |
| Versions                     | Individual valves and valve banks (manifold mounting)                 |
| Operating pressure $p_{max}$ | 420 bar   |
| Flow $Q_{max}$               | 80 (120) lpm (Size 3)   |
| $Q_{max}$                    | 160 (240) lpm (Size 5)  |

### Table of contents

|   |           |
|---|-----------|
| <b>1. General information</b>                             | <b>1</b>  |
| <b>2. Type coding, overview</b>                           | <b>2</b>  |
| <b>3. Available version, main data</b>                    | <b>4</b>  |
| 3.1 Connection blocks and end plates                      | 4         |
| 3.2 Add-on spool valves                                   | 8         |
| <b>4. Characteristic data</b>                             | <b>14</b> |
| 4.1 General and hydraulic                                 | 14        |
| 4.2 Curves  | 15        |
| 4.3 Actuators   | 16        |
| 4.4 Functional cut-off, prop. pressure limitation         | 19        |
| 4.5 Other solenoid valves                                 | 20        |
| <b>5. Unit dimensions</b>                                 | <b>21</b> |
| 5.1 Size 3  | 21        |
| 5.2 Size 5  | 30        |
| <b>6. Appendix</b>  | <b>41</b> |
| 6.1 Notes for selection and lay-out                       | 41        |
| 6.2 Circuit examples                                      | 45        |
| 6.3 Notes regarding assembly, installation and conversion | 45        |

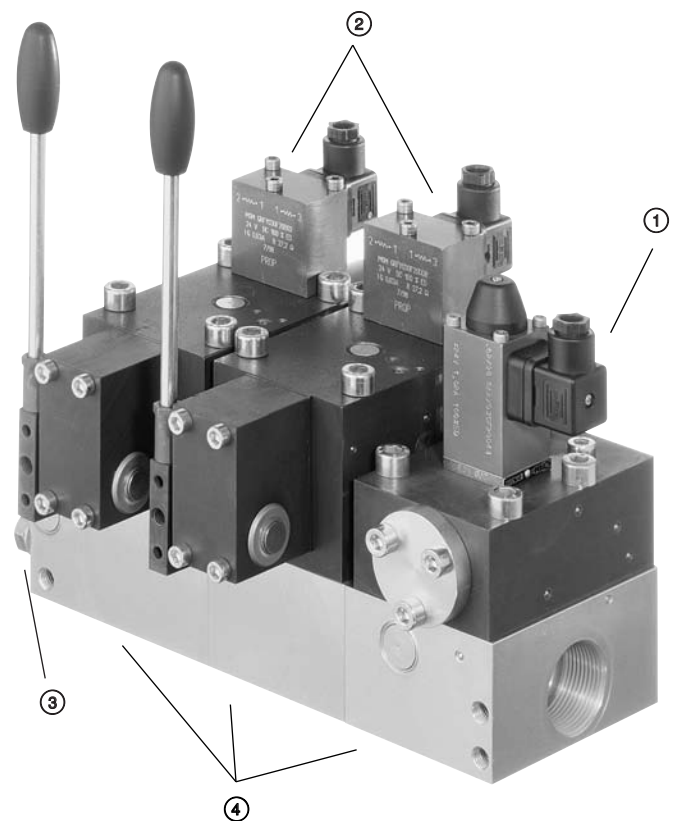

### Further technical information:

|                            |          |
|----------------------------|----------|
| Size                       | Design   |
| Size 2 (valve bank design) | D 7700-2 |
| Size 3 (valve bank design) | D 7700-3 |
| Size 5 (valve bank design) | D 7700-5 |

### Mounting

- ① Inlet section (control section)
- ② Size 5 (valve bank design)
- ③ End plate
- ④ Sub-plates

## 2. Type coding, overview

Order examples:

Valve section (for individual orders, without sub-plate)

**SLF 3 - A2 J 25/16 C300 / EA - G 24**

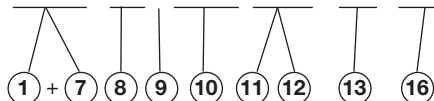

Inlet section (for individual order, without sub-plate)

**PSLF A H1 F80 / 400 - 3 - G 24**

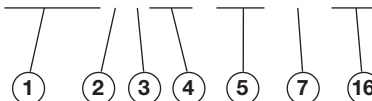

Valve bank

**PSLF A H1 F80 / 400 / 4 - 3 - A2 J 25/16 C300 /EA /3 AN320 BN320**

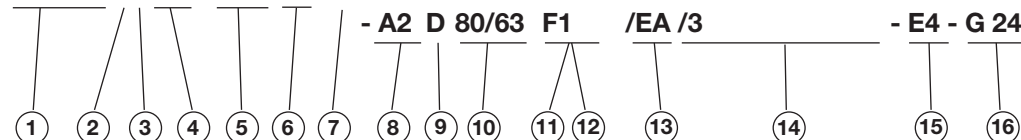

- ① Basic type coding for the valve bank or inlet section (see table 1 and 5 in sect. 3.1.1 and 3.1.2) as well as valve sections (see sect. 3.2)
- PSLF A** Supply with pressurized oil by means of fixed pump (open center)
- PSVF A** Supply with pressurized oil by means of variable displacement pump (closed center) with a delivery flow controller, or as a second, separate unit if both valve banks are connected to a constant pressure system
- SLF** Individual valve section, without sub-plate
- ② Additional elements (see table 2 and 6 in sect. 3.1.1 and 3.1.2) (no coding)
- S, W** Basic version
- S, W** Additional damping device in gallery LS (only with PSVF, standard with PSLF)
- B, B 4 ... B 7** Orifice in gallery LS (PSVF only)
- G** Restrictor check valve (type PSLF)
- H** Raised circulation pressure of the 3-way flow controller (approx. 14 bar with type PSLF)
- ③ Control oil supply (see table 7, sect. 3.1.3) (no coding)
- Without pressure reducing valve in case of an external control oil supply (min. 20 bar up to max. 40 bar)
- 1** With integrated pressure reducing valve for the internal supply of control oil (control pressure approx. 20 bar)
- 2** With integrated pressure reducing valve for the internal supply of control oil (control pressure approx. 40 bar)
- ④ Optional 2/2-way solenoid valve for arbitrary idle pump circulation (see table 8, sect. 3.1.3) (no coding)
- Without directional valve, but prepared for retrofitting
- F, Z, ZM** De-energized open = Idle pump circulation when valve is de-energized
- D, V** De-energized closed = Idle pump circulation when valve is energized
- F.. or D..** When a pressure is specified, with pressure limiting valve which can be activated as a second pressure stage (e.g. F 50)
- PA, PB, PD** Prop. pressure limiting valve, with various pressure ranges
- ⑤ Pressure limiting valve (main pressure limitation) in the inlet section (see table 9, sect. 3.1.3) (no coding)
- Without pressure limiting valve (type PSVF only)
- / ...** Pressure limiting valve factory set to ... bar
- ⑥ Sub-plate for the inlet section (see table 3, sect. 3.1.1)
- /4, /UNF 4** Size 3, standard (tapped ports for P and R G 3/4 DIN ISO 228/1 (BSPP) (BSPP) or 1 1/16-12 UN-2B SAE J 514)
- /6** Size 5, standard (tapped ports for P and R G 1 1/4 DIN ISO 228/1 (BSPP) (BSPP))
- /7 SAE** Size 5 (flange SAE 1 1/2" 6000 psi)
- ⑦ Size (see table 1 and 5, sect. 3.1.1 and 3.1.2)
- 3 or 5** Various connection hole pattern (adapter plates enabling direct mounting between size 5 and 3 with type ZPL 53 see table 10, sect. 3.1.4)
- ⑧ Valve section - Basic function (see table 12, section 3.2.1)
- A 2 (standard)** Spool valve with inflow controller for each consumer
- A 1** Spool valve without inflow controller, suitable for consumers, which are actuated individually and successively but not simultaneously (no additional functions possible)
- A 5, A 7** Inflow controller with enforced spring for higher flow
- A 8** 4/3-way directional spool valve (pre-selector valve)
- AR 2, AR 5, AR 7** like A 2, A 5, A 7 but with check valve function
- AX** Blanking plate
- ⑨ Coding for the flow-pattern (see table 14, sect. 3.2.1 and 6 c)
- L, M, F, H, J, B, R, O, P, A, Q, K, T, I, Y, Z, V, G, W, X**
- ⑩ Flow coding for port A and B (see table 15, sect. 3.2.1)
- .../...** Coding for port A or B (independently selectable)
- 3, 6, 10, 16, 25, 40, 63, 80** (size 3)
- 16, 25, 40, 63, 80, 120, 160** (size 5)
- ⑪ Secondary pressure limitation (deviating from the main pressure setting, lower pressure for the connected consumer) no shock valves (see table 15 and 17, section 3.2.1) (doesn't apply to spool valve types without inflow controller, coding A 1 ⑧ or table 12) (no coding)
- No secondary pressure limitation
- A..., B...** Only for consumer port or B
- A...B...** For consumer ports A and B
- C...** Joint for consumer port A and B (not in conjunction with coding **F..** or **S ⑫**)

- ⑫ unfunctional cut-off (see table 16 and 17, sect. 3.2.1) (doesn't apply to spool valve types without inflow controller, coding A1 ⑧ or table 12)
- (no coding) No functional cut-off
- F 1** Electrical cut-off, consumer port A
- F 2** Electrical cut-off, consumer port B
- F 3** Electrical cut-off, consumer port A and B
- FP 1(2, 3)** Like F1(2,3), however with electro-proportional pressure limitation
- FPH 1(2, 3)** Like FP1(2,3), however with additional push-button for manual emergency actuation
- S, S 1** External hydraulic load signal pick-up from the control signal port U (consumer port A) and W (consumer port B)
- ⑬ Types of actuation (see table 18 and 19, sect. 3.2.1)
- /A (1,2)** Manual actuation (suffix **1** = without hand lever, **2** = short lever)
- /E** Electro-hydraulic actuation
- /EA (1,2)** Electro-hydraulic and manual actuation (suffix **1** = without hand lever, **2** = short lever)
- /EOA (1,2)** Like /EA(1,2), however without actuation solenoid (prepared for retrofitting) (suffix **1** = without hand lever, **2** = short lever)
- /H, /HA (1,2), /F, /FA** Hydraulic without or with manual actuation
- /HEA (1,2)** Hydraulic, solenoid and manual actuation
- /C (1,2), AC(1,2)** Detent (stepless)
- /EC, /EAC** Electrical detent without or with manual actuation
- /P, /PA (1,2)** Pneumatic actuation without or with manual actuation
- /... Suffix**
- G** Reinforced version
- N (1)** Proximity switch
- V, VA, VB, VC,** Contact switch monitoring
- VCHO, VCHC,** the spool elevation
- VCHOC**
- B** Solenoid with quarter-turn type plug
- WA, WA-EX n** Displacement transducer
- U** Lift monitoring (side indication)
- T, BT** Manual emergency actuation
- TH** Manual emergency actuation with pushbutton
- ⑭ Sub-plate for the individual valve section (see table 20, section 3.2.2)
- /3..** = G 1/2 (ISO 228/1 (BSPP))
- /4..** = G 3/4 (ISO 228/1 (BSPP))
- /5..** = G 1 (ISO 228/1 (BSPP))
- /UNF 3..** = 7/8-14 UNF-2B (SAE-10)
- /UNF 4..** = 1 1/16-12 UN-2B acc. to SAE J 514)
- /3, /4,** Size 3
- /UNF 3, /UNF 4**
- /38, /58** Size 3 or 5, sub-plate for pre-selector valve function
- /3 AN.. BN..** Size 3, shock and suction valves at A or B together with pressure specification
- /UNF 3 AN.. BN..**
- /3 AN.., /3 BN..,** Size 3, shock and suction valves at A or B together with pressure specification
- /UNF 3 AN.., /UNF 3 BN..**
- /3 A..B..** Size 3, shock valve at A and B together with pressure specification
- /3 A.., /3 B..** Size 3, shock valve at A or B together with pressure specification
- /5** Size 5
- /5 S** Size 5, with load signal pick-up from control signal port U (consumer port A) and W (consumer port B)
- /53, 533, 534** Sub-plate size 5, prepared to accept valve sections size 3
- /3X, /4X, /5X,** Size 3 or 5, with joint load signal pick-up via port X
- /UNF 3X, /UNF 4W** Size 5, ports A and B with flange SAE 1" (6000 psi)
- /5 SAE** Size 5, see /5 S or /58, ports A, B with flange SAE 1" (6000 psi)
- /5 SAE S, /5 SAE 8** Size 5, double sub-plate, ports A, B with flange SAE 1 1/4" (6000 psi)
- /6 D SAE** Size 5, intermediate plate with shock and suction valves
- /Z AN..BN..**
- ⑮ End plates (see table 10, section 3.1.4)
- E 1, E 1 SAE** With T-port for control oil return externally to the tank (basic type)
- E 2, E 2 SAE** Like E 1, with additional port Y for connection to the LS-port of a further, separately located PSV spool valve (total number of the sequential add-on valves 12)
- E 3** Like E 1, with additional 3/2-way directional solenoid valve for arbitrary shut-off of pump circulation during idle position of the valve spools
- E 4, E 4 SAE** Like E1, however without T-port, internal control oil return, max. pressure 10 bar!
- E 5, E 5 SAE** Like E 2, however without T-port (as E 4)
- E 6** Like E 3, however without T-port (as E 4)
- E 7, E 8, E 9, E 10** Like E 1, E 2, E 4 or E 5 but with additional return port
- ZPL 53, ZPL 5 SAE 3** Adapter plates enabling direct mounting of directional spool valves size 5 and 3
- ⑯ Nom. solenoid voltage (see table 4, sect. 3.1.1)
- G 12** 12 V DC, connection conf. EN 175 301-803 A,
- G 24** 24 V DC, connection conf. EN 175 301-803 A,
- G 24 H 4** 24 V DC, connection conf. EN 175 301-803 A, 4-pin
- G 24 C 4** 24 V DC, connection conf. EN 175 301-803 C, 4-pin
- G 24 EX** 24 V DC, explosion-proof version, acc. to ATEX
- G 24 EX 70** 24 V DC, explosion-proof version, acc. to ATEX (ambient temperature 70°C)
- G 24 MSHA** 24 V DC, explosion-proof version, acc. to MSHA
- G 12 IS** 12 V DC, explosion-proof version, flame proof, intrinsically safe acc. to ATEX (I M2 Ex d ib I)
- AMP 24 H 4** 24 V DC port via AMP Junior Timer

### 3. Available versions, main data

#### 3.1 Inlet section (control section)

There are two basic variations of connection blocks:

- Connection blocks with integrated 3-way flow controller, suitable for a fixed pump system (open-center) -type PSLF (see sect. 3.1.1)
- Connection blocks suited for a variable displacement pump system (closed center), a constant pressure systems, or if a second or more separately located directional spool valve banks are fed in parallel - type PSVF (see sect. 3.1.2).

Order coding for an inlet section as individual section (examples):  
(Attention: Size specification absolutely necessary - 3 or -5)

**PSLF A1 F/250 - 3 - G 24**  
**PSVF A2/300 - 5**

#### 3.1.1 Inlet sections for fixed pump systems (with integrated 3-way flow controller) type PSLF

Order examples:

**PSLF A** 1F/300 /4 - 3 -...-E1 - **G 24** (valve bank)  
**PSLF A H** 1F/300 - 3 - **G 24** (individual section)

Table 2

Table 1

Table 10

**Table 1:** Basic type and size

| Coding and size    | Description        | Max. pump delivery flow (lpm) |
|--------------------|--------------------|-------------------------------|
| <b>PSLF A ..-3</b> | Individual section | approx. 100                   |
| <b>PSLF A ..-5</b> |                    | approx. 350                   |

Type PSLF...-5 can be converted any time for use with variable displacement pumps (similar to type PSVF AS..-5), see sect. 6.3.3.

**Table 2:** Coding for additional elements for notes and descriptions, see sect. 6.1 a)

| Coding    | Description  |
|-----------|--|
| no coding | <b>Standard</b> Integrated combination of orifice, check valve, pre-load valve (pre-load pressure approx. 25 bar).   |
| <b>W</b>  | Like standard, but with increased throttle effect  |
| <b>G</b>  | Restrictor check valve (without sequence valve), increased throttling effect   |
| <b>H</b>  | Coding for 3-way flow controller with increased circulation pressure (see sect. 4.2). Intended for valve spools with increased flow (coding 5 acc. to table 15), pre-selector spool valve (coding 8 table 13). |
| <b>T</b>  | Only available for type PSLF A..-3<br>Provision for locking the 3-way flow controller to enable use with variable pump systems.  |

**Table 3:** Coding of the sub-plate for the inlet sections

| Coding        | Size | Ports ISO 228/1 (BSPP) or SAE 514 J |                |
|---------------|------|-------------------------------------|----------------|
|               |      | P and R                             | LS, M, T and Z |
| <b>/4</b>     | 3    | G 3/4                               | G 1/4          |
| <b>/UNF 4</b> | 3    | 1 1/16-12 UN-2B                     | 7/16-20 UNF-2B |
| <b>/6</b>     | 5    | G 1 1/4                             | G 1/4          |
| <b>/7 SAE</b> | 5    | SAE 1 1/2" (6000 psi)               | G 1/4          |

**Note:** Sub-plates with SAE-flange must not be combined with sub-plates featuring tapped ports (e.g. /5 S)

#### Symbols

Basic type and additional elements (see table 1 and 2)

Sub-plates (see table 3)

Additional elements

These additional elements are illustrated in flow pattern symbols of size 3, they do apply to size 5 in the same way.

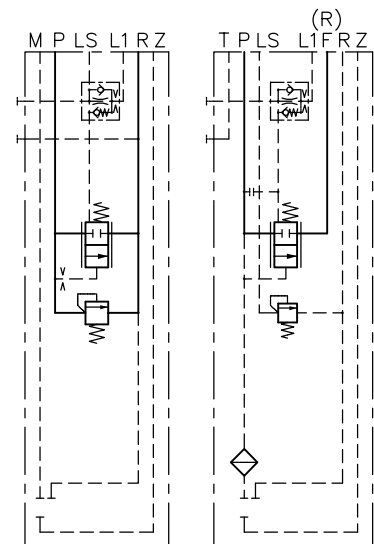

**PSLF A(H)../..-3**  
**PSLF A(H)W../..-3**

**PSLF A(H)../..-5**  
**PSLF A(H)W../..-5**

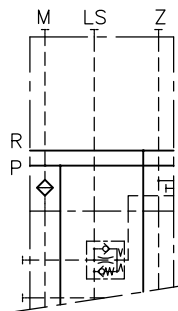

**PSLF A../..-4-3**  
**PSLF A../..-UNF 4-3**

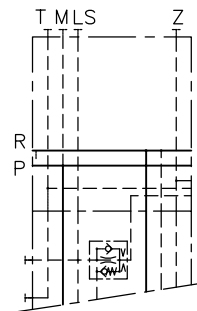

**PSLF A../..-6-5**  
**PSLF A../..-7 SAE-5**

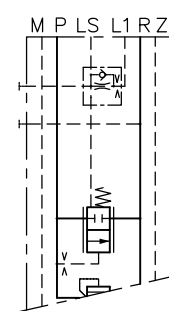

**PSLF AG../..-3**  
**PSLF AG../..-5**

**3.1.2 Inlet sections for variable displacement pump systems / constant pressure system or for a second and all other separately parallel connected directional spool valve banks type PSVF**

Order examples:

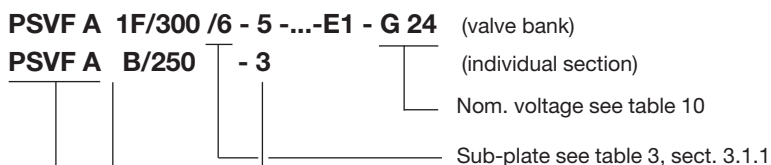

**Table 5:** Basic type and size

| Coding and size    | Description        | Max. pump delivery flow (lpm) |
|--------------------|--------------------|-------------------------------|
| <b>PSLF A ..-3</b> | Individual section | approx. 100                   |
| <b>PSLF A ..-5</b> |                    | approx. 350                   |

Type PSLF...-5 can be converted any time for use with variable displacement pumps (similar to type PSVF AS...-5), see sect. 6.3.3.

**Table 4:**

Code letter for features within the LS-signal duct for the damping of pump flow controllers (for notes and explanation, see sect. 6.1 a)  
 Additional features only suitable where variable displacement pumps are used (limitation of the control oil flow). Observe note at table 9!

| Coding                    | Description   |
|---------------------------|---|
| no coding                 | <b>Standard</b> , without additional element  |
| <b>S</b>                  | With integrated combination of orifice, check valve, pre-load valve (pre-load pressure approx. 25 bar) like standard element of type PSLF |
| <b>W</b>                  | Like S, but with increased throttle effect  |
| <b>B</b>                  | With orifice $\varnothing$ 0.8 mm within LS-duct (limiting the control oil flow)  |
| <b>B 4, B 5, B 6, B 7</b> | With orifice $\varnothing$ 0.4 mm, 0.5 mm, 0.6 mm or 0.7 mm within LS-duct  |

**Symbols**

Basic type (see table 5)

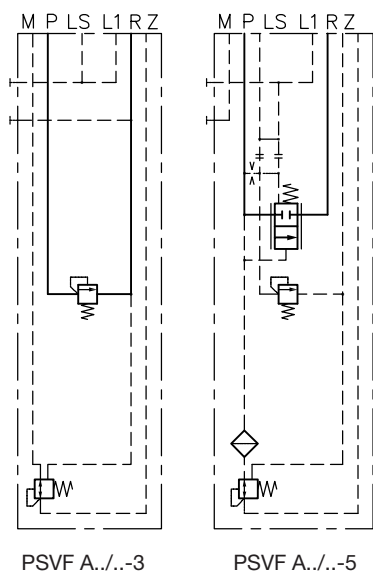

Sub-plates (see table 3)

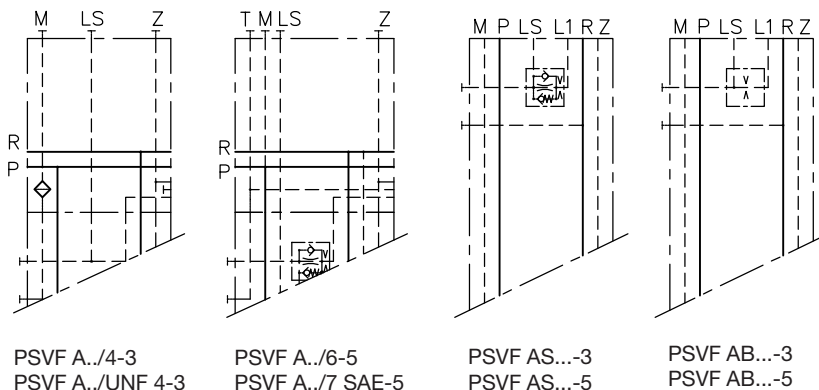

Additional elements (see table 6) <sup>1)</sup>

These additional elements are illustrated in flow pattern symbols of size 3, they do apply to size 5 in the same way.

**3.1.3 Additional elements for the inlet sections**

Order examples: PSLF A. **1F100 /380**/4 - 3 -...- E1 - G24  
 PSVF A. **1F /350** -5 - G24

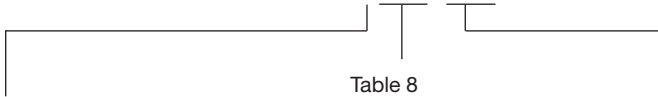

**Table 7:** Coding for control oil supply (for symbol, see sect. 3.1.1 and 3.1.2)

| Coding    | Description   |
|-----------|---|
| no coding | Without pressure reducing valve for actuation coding A, C or P acc. to sect. 3.2, table 18 or in the case of external control oil supply (20-40 bar) for other actuations   |
| <b>1</b>  | With integrated pressure reducing valve for internal control oil supply for actuations coding H(HA, HEA, F, FA, FEA).. and E(EA).. or as pick-up for other control valves (max. permissible control oil flow approx. 2 lpm) |
| <b>2</b>  | Control pressure:<br>Coding 1: approx. 20 bar (+ return pressure at R)<br>Coding 2: approx. 40 bar (+ return pressure at R)   |

**Table 9:** Tool adjustable pressure limiting valve for the main pressure.  
 Adjustable from 50 up to 400 bar, after loosening the lock-nut (for symbol, see sect. 3.1.1 and 3.1.2).

| Coding      | Description   |
|-------------|---|
| no coding   | Version without pressure limiting valve (only type PSVF)  |
| <b>/...</b> | With pressure limiting valve at PSLF and PSVF (pressure specification in bar)<br><br>Non piloted: PSL(V)F ...- 3<br>Piloted: PSL(V)F ...- 5 |

**Table 8:** Arbitrary idle pump circulation of all consumers by means of 2/2-way solenoid valve type WN 1 conforming D 7470 A/1, 2/2-way solenoid valve type EM 21 DE(DSE) conforming D 7490/1 E or prop. pressure limiting valve

| Coding                           | Description  |
|----------------------------------|--|
| no coding                        | If not required  |
| <b>F</b>                         | With WN 1F, idle pump circulation if valve is de-energized (emergency stop)  |
| <b>D</b>                         | With WN 1D, idle pump circulation if valve is energized  |
| <b>F...</b><br>or<br><b>D...</b> | With pressure limiting valve, which can be activated as a second pressure stage (specify pressure in bar) (pre-set pressure, tool adjustable from 50 to 400 bar). Example:<br>PSLF A 1 F100/350-3..<br>De-energized $p_{max} = 100$ bar<br>Energized $p_{max} = 350$ bar |

**Note:** To limit the control oil flow, when using the idle pump circulation with type PSV an additional element coding S, W or B 4, B 5, B 6 acc. to table 5 is required.

**Attention:** Observe note in sect. 6.1 a when using the valves for an emergency stop function!

| Coding            | Description   |
|-------------------|---|
| <b>PA, PB, PD</b> | Prop. pressure limiting valve enabling variable adjustment of the system pressure; Pressure range: PA 100...320 bar, PB 15...250 bar, PD 18...400 bar |
| <b>Z</b>          | With type EM 21 DSE, idle pump circulation if valve is de-energized (emergency stop)  |
| <b>ZM</b>         | Like Z, but with lead sealed wing screw for emergency operation   |
| <b>V</b>          | With type EM 21 DE, idle pump circulation if valve is energized   |
| <b>X...</b>       | Additional LS pressure limitation (50...400 bar)<br>Not suited to compensate pressure peaks on the consumer side.                                     |

**Symbols**

These additional elements are illustrated in flow pattern symbols of size 3, they do apply to size 5 in the same way.

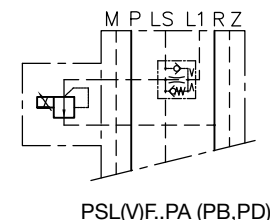
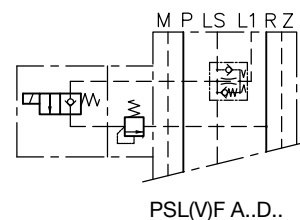
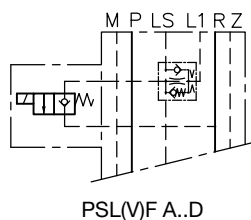
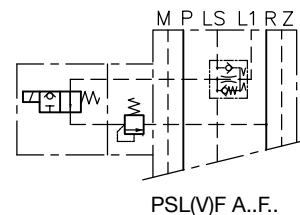
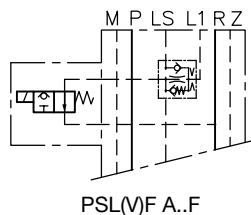
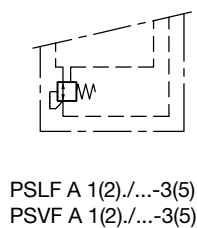

**Table 10:** Nominal voltage for solenoid actuation acc. to table 20 for all solenoid actuated functions of the valve bank, for details see sect. 4.3 and 4.5

| Coding                                      | Nominal voltage | Description  |
|---|-----------------|--|
| <b>G 12</b> <b>X 12</b>                     | 12 V DC         | Standard, version with connection conf. EN 175 301-803 A with (G ..) or without (X ..) plug  |
| <b>G 24</b> <b>X 24</b>                     | 24 V DC         |  |
| <b>G 24 H 4</b> <b>X 24 H 4</b>             | 24 V DC         | Like G 24 (X 24), but solenoid for electrical actuation 4-pin, see sect. 4.3   |
| <b>G 24 C 4</b> <b>X 24 C 4</b>             | 24 V DC         | Version with connection conf. EN 175 301-803 C, 4-pin at solenoid actuation (table 20), with (G ..) or without (X ..) plug, see 4.3  |
| <b>AMP 24 H 4</b>                           | 24 V DC         | Version with connection via AMP Junior Timer, 4-pin at electrical actuation (table 20), all other solenoid actuated functions are 2-pin  |
| <b>G 24 EX</b><br><b>G 24 EX-10 m</b>       | 24 V DC         | For use in areas with explosion hazardous atmosphere. Suited for category 2 and 3, zone 1, 21, 2, 22.<br>Protection class EEx m II 120° (T4), with cable length 3 m (no coding) or 10 m                            |
| <b>G 24 EX 70</b><br><b>G 24 EX 70-10 m</b> | 24 V DC         | Like G 24 EX .. , but for ambient temperature < 70°C   |
| <b>G 12 IS</b><br><b>G 12 IS-10 m</b>       | 12 V DC         | For use in mines and its on-surface systems, which can be endangered by firedamp and/or combustible dust. Protection class I M2 Ex d ib I (flame proof, intrinsic safe), with cable length 5 m (no coding) or 10 m |
| <b>G 24 MSHA</b><br><b>G 24 MSHA-10 m</b>   | 24 V DC         | For use in mines and its on-surface systems, where a MSHA (USA) or MA (China) approval is mandatory. Protection class I M2 Ex d I (flame proof, intrinsic safe), with cable length 5 m (no coding) or 10 m         |

- Note:**
- Solenoids of explosion-proof design are only available for actuation E, EA or HE (A) (table 20).
  - An intermediate plate ZPL 33/5 (see table 22) has to be provided between the valve sections when using solenoids G 12 IS .. and G 24 MSHA ...
  - Coding G 24 C (X 24 C) is only available for solenoids of the electrical actuation (table 20) where there is no manual emergency actuation.
  - Coding AMP 24 not available for idle circulation valves coding D and F (table 8), intermediate plates ZPL 3 S (V) E (table 22), end plates E 3, E 6 (table 11), intermediate plates /ZDS, /ZDR (table 19), functional cut-off, (table 17)

**3.1.4 End plates of valve bank**

Order example: PSLF A1 F100/380/6 - 5 -... - **E 1** - G 24

**Table 11:** End plates

| End plate  |                                     | Description  |
|--|-------------------------------------|--|
| External port T (separate return pipe to the tank) | Internal control oil return gallery | Order coding of an end plate as separate part (example): <b>SLF 5 - E 1</b><br><b>SLF 3 - E 6 - G 24</b><br>(State the size: SLF3- or -SLF5- !)    |
| <b>E 1</b><br><b>E 1 SAE</b>                       | <b>E 4</b><br><b>E 4 SAE</b>        | Standard end plate   |
| <b>E 2</b><br><b>E 2 SAE</b>                       | <b>E 5</b><br><b>E 5 SAE</b>        | With additional inlet port Y e.g. for connecting the LS-control pipe of a subsequent PSVF spool valve bank.  |
| <b>E 3</b>   | <b>E 6</b>                          | Possibility for arbitrary shut-off of the idle pump circulation by means of a directly mounted 3/2-way direct. seated valve WN1H acc. to D 7470A/1 |
| <b>E 7</b>   | <b>E 9</b>                          | Like E 1/E 4, but with additional return port R (only size 3)  |
| <b>E 8</b>   | <b>E 10</b>                         | Like E 2/E 5, but with additional return port R (only size 3)  |
| <b>ZPL 53</b><br><b>ZPL 5 SAE 3</b>                |                                     | Adapter plate to continue a prop. directional valve bank size 5 with sections of size 3.<br>As separate part: <b>SLF 5-ZPL 53</b>                  |

- Note:**
- The internal control oil return gallery is to be used only in systems where the return pressure is below 10 bar.
  - End plates E.SAE in combination with sub-plates /..SAE (only size 5) or adapter plate ZPL 5 SAE 3 as conversion from sub-plates /.SAE size 5 to size 3

**Symbols**

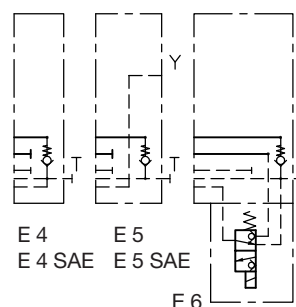
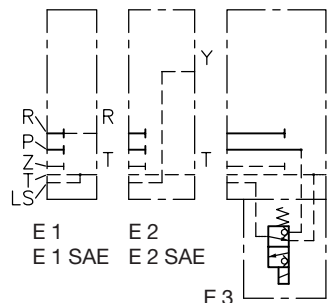

### 3.2 Valve sections

#### 3.2.1 Directional spool valve (individual valve)

Order examples: (valve bank) PSLF A1 F/320/4 - **3 - A2 L 63/40 F1 /EA /3 AN320 BN320** - E1 - G 24  
 (individual section) SLF **5 - A5 J 160/160 C250 /EA** - G 24

Size

Table 20

Table 17

Table 16



Table 15

Table 14



Sect. 3.2.2

**Note:** Size specification is absolutely necessary!  
 The valve spools are subsequently interchangeable, e.g. if a different flow rating than initially planned becomes necessary (see sect. 6.3.4)

**Table 13:** Spool valve, basic version

| Coding                                      | Description   |   |
|---|---|---|
| <b>A 2</b>                                  | <b>Standard</b> , with inflow controller, for simultaneous load compensated moving of several consumers (3/3-, 4/3-way spool valve, standard type)  |   |
| <b>A 1</b>                                  | Without inflow controller intended for singly / successively actuated functions. Additional functions on the consumer side are not possible. For the max. consumer flow of the individual consumer, see table 15 and sect. 6.1 b)   |   |
| <b>A 5</b>                                  | With inflow controller (for symbol, see coding A2) but with reinforced spring at the 2-way flow controller (control pressure approx. 9 bar). Only usable in conjunction with connection block type PSLF AH./...-3- or type PSVF with variable displacement pump / constant pressure system. Note see sect. 6.1 a and b. |   |
| <b>A 7</b>                                  | With inflow controller (like coding 2) but enforced 2-way controller spring (control pressure approx. 13 bar). Only available in combination with connection block type PSVF and variable displacement pump/constant pressure system, see note in sect. 6.1 b)  |   |
| <b>A 26</b><br><b>A 56</b>                  | Only size 3: With inflow controller coding 2 or 5, and additional rebound damping; Especially suited for oscillation inducing consumers (e.g. hydraulic motors with a low number of pistons)  |  |
| <b>A 8</b>                                  | 4/3-way directional spool valve, Makes only sense with flow pattern symbol L and H and maximum flow. Only usable in conjunction with connection block type PSLF.H./... or type PSVF with variable displacement pump / constant pressure system.   |   |
| <b>AR 2,</b><br><b>AR 5,</b><br><b>AR 7</b> | Like coding 2, 5, 7, but with additional check valve functionality (spool valve = slight leakage), see sect. 6.1 b<br>Only usable in conjunction with connection block type PSLF.H./... or type PSVF with variable displacement pump / constant pressure system.  |  |
| <b>AX</b>                                   | Blanking plate  |   |

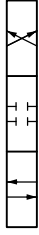
**Table 14:** Symbols

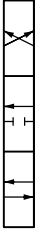
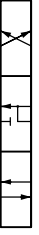
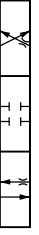
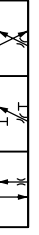
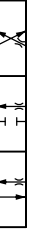
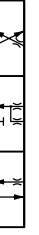
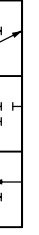
| L   | M   | F   | H   | J   | B   | R   | O   | G   |
|---|---|---|---|---|---|---|---|---|
|  |  |  |  |  |  |  |  |  |

|   |   |
|---|---|
| <b>J, B, R, O,</b><br><b>I, Y, Z, V</b> | Valve spool with return throttling to assist oscillation dampening, see sect. 6.1 c                 |
| <b>G</b>                                | 3/3-way spool valve, observe note in sect. 6.1 c  |
| <b>W</b>                                | 4/2-way spool valve, observe note in sect. 6.1 c  |
| <b>A, K, P, Q, T</b>                    | Valve spool with positive overlapping, see sect. 6.1 c, only size 3                                 |
| <b>HW, OW</b>                           | Valve spool with wider fitting to prevent spool sticking - intended for contamination prone systems |
| <b>X</b>                                | 2/2-way directional spool valve for hydraulic motors, see sect. 6.1 e, only size 3                  |

**Table 15:** Max. flow P → A(B) acc. to the coding

| Valve spool coding acc. to table 12   |  | Coding and flow Q <sub>A, B</sub> (lpm) at consumer port A and B |    |    |    |    |    |    |     |     |     |
|---|--|--|----|----|----|----|----|----|-----|-----|-----|
| Coding  | Size   | 3  | 6  | 10 | 16 | 25 | 40 | 63 | 80  | 120 | 160 |
| <b>A 2</b>  | 3  | 3  | 6  | 10 | 16 | 25 | 40 | 63 | 80  | --  | --  |
|   | 5  | --   | -- | -- | 16 | 25 | 40 | 63 | 80  | 120 | 160 |
| <b>A 1, A 8</b>   | 3  | 4  | 9  | 14 | 22 | 34 | 54 | 85 | 107 | --  | --  |
|   | 5  | --   | -- | -- | 20 | 32 | 51 | 80 | 110 | 150 | 210 |
| Valid for PSLF (integrated 3-way flow controller: $\Delta p \sim 10$ bar), otherwise as guide line $Q_{A, B} \approx Q_{nom} \sqrt{0,2 \cdot \Delta p_{controller}}$<br>Q <sub>rating</sub> - flow for code number A 2;<br>$\Delta p_{controller}$ stand-by pressure of the flow controller of the pump<br>Example (size 3): Q <sub>rating</sub> = 25 lpm, $\Delta p_{controller}$ = 14 bar;<br>Q <sub>A;B</sub> ≈ 42 lpm |  |  |    |    |    |    |    |    |     |     |     |
| <b>A 5</b>  | 3  | 4  | 9  | 14 | 22 | 34 | 54 | 85 | 107 | --  | --  |
|   | 5  | --   | -- | -- | 20 | 32 | 51 | 80 | 110 | 150 | 210 |
| <b>A 7</b>  | 3  | 5  | 10 | 14 | 24 | 37 | 59 | 93 | 118 | --  | --  |
|   | 5  | --   | -- | -- | 23 | 37 | 60 | 95 | 130 | 175 | 240 |
| <b>Note:</b>  | The flow rate for the consumer ports A and B can be individually selected, e.g. 63/40, 40/80. This provides optimal adaptation to the respective consumer while exploiting the full functional spool lift. In addition there is the possibility of mechanical stroke limitation. |  |    |    |    |    |    |    |     |     |     |

**Table 16:** Secondary pressure limiting valves, only available with spool valves featuring an inflow controller, coding A 2 and A 5 (acc. to table 12!). These are no shock valves!

| Coding  | Description  |
|---|--|
| no coding   | Without pressure limitation  |
| <b>A...</b>   | Pressure limitation at A with pressure specification               |
| <b>B...</b>   | Pressure limitation at B with pressure specification               |
| <b>A...B...</b>   | Pressure limitation at A and B with pressure specification         |
| <b>C...</b>   | Common pressure limitation for A and B with pressure specification |
| Pressure limitation $p_{min} = 50$ bar; $p_{max} = 420$ bar<br>Example: SLF 3-A 2 H63/40 <b>A250 B200/A</b> |  |

**Table 18:** Combination possibilities for additional functions

| Pressure limitation   | Functional cut-off |            |  |
|---|--------------------|------------|--|
|   | no coding          | <b>S 1</b> | <b>F 1, F 2, F 3, S 1<br/>FP 1, FP 2, FP 3<br/>FPH 1, FPH 2, FPH 3</b> |
| no coding   | ●                  | ●          | ●  |
| <b>A or B<br/>A and B</b>   | ●                  | ●          | ●  |
| <b>C</b>  | ●                  | --         | --   |
| The signal ports are apparent as standard (see flow pattern symbols on page 10) in combination with coding A..., B..., A..B.. (see table 15 and 17) and F.1 (2,3), S1 (table 16 and 17) |                    |            |  |

**Table 17:** Functional cut-off or prop. pressure limitation (only available with spool valves with inflow controller coding A 2, A 5 and A 7 acc. to table 15!)

| Coding  | Description   |
|---|---|
| no coding   | Without functional cut-off  |
| <b>F 1, F 2</b>   | Electric functional cut-off at A or B   |
| <b>F 3</b>  | Electric functional cut-off at A and B  |
| <b>FP 1, FP 2, FP 3<br/>FPH 1, FPH 2, FPH 3</b>   | Prop. pressure limitation for A or B resp. A and B, Version FPH. with additional emergency actuation (no tools needed)  |
| <b>S</b>  | Only size 5: flange sided load signal ports U and W (G 1/8) for external piping, e.g. in combination with sub-plate /5 S, see sect. 3.2.2 table 20;<br>Example: SLF 5-A 2 H 160/80 S/5 S<br><br>The signal ports are apparent as standard (see flow pattern symbols on page 10) in combination with coding A..., B..., A..B.. (see table 15 and 17) and F.1 (2,3), S1 (table 16 and 17) |
| <b>S 1</b>  | Load signal ports U and W (G 1/8) for external piping; tapped ports at valve section  |
| <ul style="list-style-type: none"> <li>● There remains a residual pressure when the LS gallery is relieved. When the return line is depressurized the residual pressure will be: <math>p_{relieved} = \Delta p_{block} + \Delta p_{controller}</math> (<math>\Delta p_{controller}</math> = control pressure of the inflow controller acc. to table 13)<br/>                             Coding F., FP.: <math>\Delta p_{block} = 10</math> bar<br/>                             Coding S, S 1, (X): <math>\Delta p_{block} = 5</math> bar</li> <li>● One joint LS-port X is standard on the flange side (see dimensional drawings, sect. 5)</li> <li>● Size 5: combinations of coding F..1, FP.. or S 1 and solenoids G 24 MSHA or G 12 IS are not available!</li> <li>● Coding F.., FP.. not available with solenoids G 24 Ex 70 and G 12 IS</li> </ul> |   |

**Basic version  
(individual section  
acc. to table 12)**

With respect to flow configuration and actuation, these symbols are neutral and must be supplemented by the corresponding flow pattern symbols illustrated in table 13 or 18 and 19, see also example in sect. 6.2

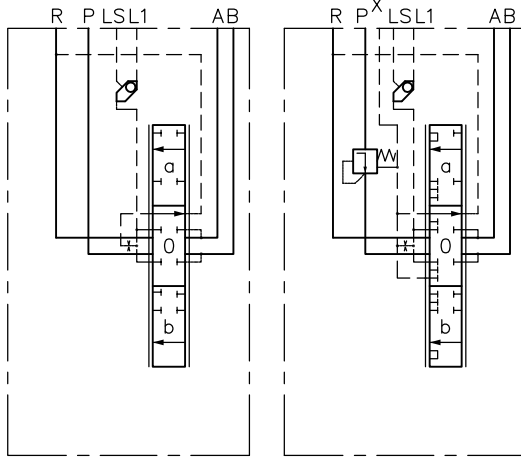

Example :  
SLF 5-A 2 J63/40  
A 250 B 310  
F 3/EA-G 24

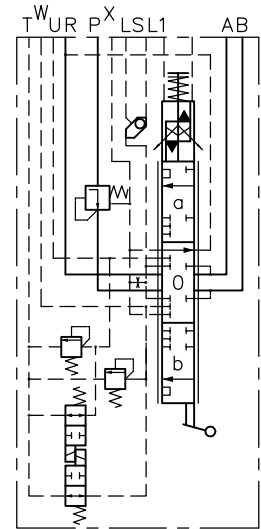

4/3-way directional spool valve without inflow controller A 1... (A 8...)

4/3-way directional spool valve with inflow controller A 2... (A 5...)

Additional function: Secondary pressure limitation acc. to table 15 for spool valves with inflow controller (no shock valve!)

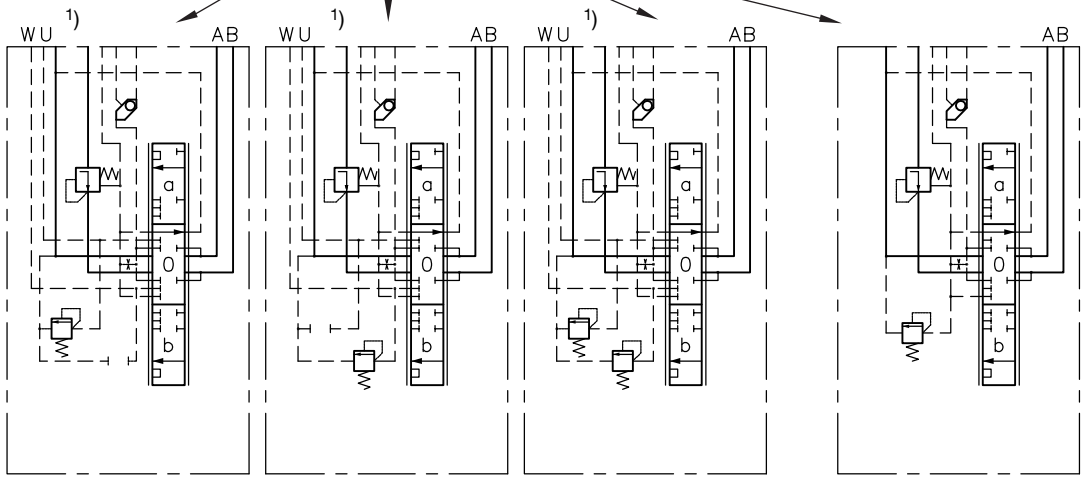

..A...

..B...

..A...B...

..C...

Functional cut-off, acc. to table 16, for spool valves with inflow controller

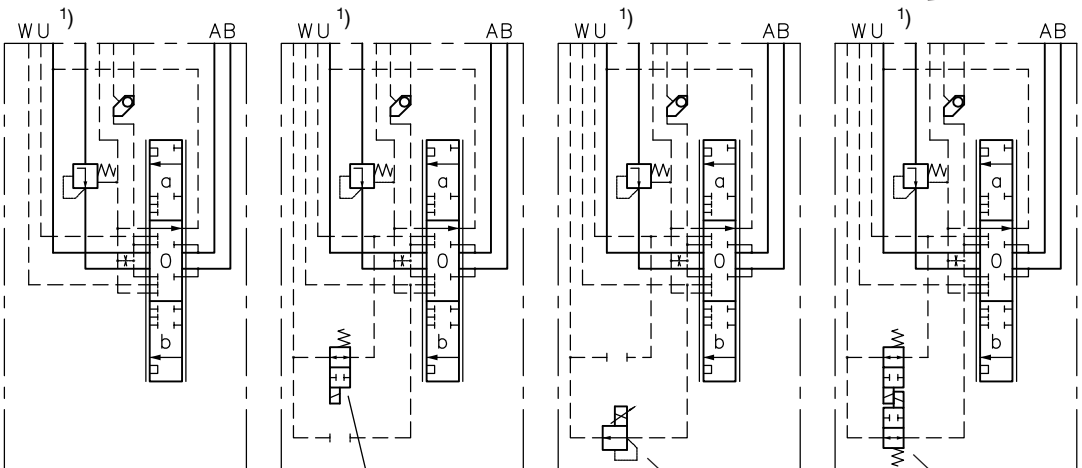

here type F1

here type FP 2

here type F3

Combination possibilities:

..S  
(only size 5)

..F(FP, FPH)1  
A..F(FP, FPH)1  
B..F(FP, FPH)1  
A..B..F(FP, FPH)1

..F(FP, FPH)2  
A..F(FP, FPH)2  
B..F(FP, FPH)2  
A..B..F(FP, FPH)2

..F(FP, FPH)3  
A..F(FP, FPH)3  
B..F(FP, FPH)3  
A..B..F(FP, FPH)3







1) Ports U and W on the flange side only with size 5, see description in table 16, coding S

**Table 20:** Types of actuation (for further explanations, see sect. 4.3)

| Nomenclature          | Manual actuation                                       |        | Electro-hydraulic actuation   |                                    | Hydraulic actuation  |                                   |  | Pneumatic actuation  |         |
|-----------------------|--|--------|---|------------------------------------|--|-----------------------------------|--|--|---------|
|                       | Spring return  | Detent | electro-hydraulic   | Combina-tion with manual actuation | hydraulic  | Combination with manual actuation | Combination with solenoid and manual actuation |  |         |
| Coding                | BG 3   | A      | C   | E                                  | EA<br>E0A<br>EAC   | F<br>F UNF                        | FA<br>FA UNF                                   | FEA<br>FEA UNF   | P<br>PA |
|                       | BG 5   |        | AC  | EC                                 |  | H<br>H UNF                        | HA<br>HA UNF                                   | HEA<br>HEA UNF   |         |
| Symbol                |  |        |   |                                    |  |                                   |  |  |         |
| Manipulated variables | Actuation angle<br>min. approx. 5°<br>max. approx. 30° |        | Control current ratio<br>I/I <sub>N</sub><br>min. approx. 0.2<br>max. approx. 1 |                                    | Control pressure<br>min. approx. 5 bar<br>max. approx. 18 bar<br>max. perm. 50 |                                   |  | Control pressure<br>min.<br>approx. 2.5 bar<br>max.<br>approx. 7 bar |         |

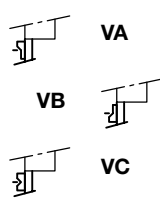
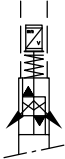
- Note:**
- Approximate values for start of flow at A or B (= min) up to max. consumer flow according to the flow coding table 15, see curves sect. 4.2.
  - Difference between actuation H.. and F.. is the position of the control line ports. With actuations HE(A) or FE(A) observe also notes and circuit examples in sect. 6.1 i
  - Type E0A prepared for retrofitting of a solenoid actuation
  - Type AC, EC, and EAC with detent in end position, stroke limitation not possible

**Table 20:** Additional features for actuations

| Type of actuation/coding | Suffix  | Description   | Example                   | Symbols   |
|--------------------------|---|---|---------------------------|---|
| A, EA, HA, PA, C         | <b>1</b>  | Manual actuation without hand lever   | EA 1, C 1                 |  |
| A, EA, HA, PA, C         | <b>2</b>  | Manual actuation with short hand lever. For dimensions see sect. 5.3.   | EA 2, A 2                 |  |
| A, EA, HA, C             | <b>V</b><br><b>VA</b><br><b>VB</b><br><b>VC</b><br><b>VCHO</b><br><b>VCHC</b> | Mechanical micro switch (size 3 only), for monitoring the spool's idle position, (for data of the switch, see sect. 4.3<br>V - Signal with start of movement, direction A or B (no side indication)<br>VA - Signal with start of movement, direction A<br>VB - Signal with start of movement, direction B<br>VC - Signal with start of movement, direction A and B (separate side indication)<br>VCHO - Signal with start of movement, direction A and B separate (2xNO-contact)<br>VCHC - Signal with start of movement, direction A and B separate (2xNC-contact) | EA VA,<br>A 1 VB,<br>C VC |  |
| A, EA, C                 | <b>N, N1</b>  | Proximity switch (size 3 only), for monitoring the spool's idle position (no side indication), for data, see sect. 4.3.<br>Type N1- only mechanical setup: Proximity switch is customer furnished (8x8x33mm central sensor area).   | EA N,<br>A 1 N 1          |  |
| A, EA, C, PA, K          | <b>WA</b><br><b>WA-EX n</b>   | Integrated displacement transducer (Hall-sensor) with analogous signal output (lift monitoring)<br>(WA-EX n, explosion-proof version conf. Ex nA II T4 X)   | EA W,<br>A 1 W,<br>EA BW  |  |
| A, EA, C, PA, K          | <b>U</b>  | Integrated spool monitoring for side indication (Triggered signal: ON / OFF)  | EA U                      |  |
| E, EA, HEA               | <b>T</b><br><b>TH</b>   | Additional manual emergency actuation for the solenoid at the integrated prop. Pressure reducing valve. Version TH with additional pushbutton for actuation without tool  | ET, EA 1 T,<br>EW TH      |  |
| A, C, E, E0A             | <b>G</b>  | Reinforced version of the spring cover, suitable if high pressure surges are expected in the gallery T.   | ET 1 G, CG,<br>A 1 G      |   |
| E, EA, HEA               | <b>B, BT</b>  | Solenoid with quarter turn type plug (Bayonet PA 6, Co. Schlemmer D-85586 Poing, suited for taper with bayonet 10 SL), version BT with additional manual emergency actuation. Plug is not scope of delivery.  | EB, EAB,<br>EA 1 B        |   |

3.2.2 Sub-plates

Order example: PSLF A1 F/320-3-A2 L 63/40 A300 F1/EA /3 AN320 BN320 - E1 - G 24  
 PSVF A2/300-5-A2 J 160/120/EA /Z AN300 BN280/5 - E4 - G 24

Table 21: Sub-plates

| Coding   | Port size for A and B |                                    | Size | Description  |
|--|-----------------------|------------------------------------|------|--|
|  | ISO 228/1 (BSPP)      | SAE J 514                          |      |  |
| /3, /UNF 3   | G 1/2                 | 7/8-14 UNF-2B                      | 3    | <b>Standard</b>  |
| /38  | G 1/2                 | --                                 | 3    | Sub-plate for pre-selector valve type SLF 3-A 8  |
| /4, /UNF 4   | G 3/4                 | 7/8-14 UNF-2B                      | 3    | <b>Standard</b>  |
| /5   | G 1                   | --                                 | 3    | <b>Standard</b>  |
| /3 AN... BN...<br>/3 AN...<br>/3 BN...<br>/UNF 3 AN... BN...<br>/UNF 3 AN...<br>/UNF 3 BN... | G 1/2                 | 7/8-14 UNF-2B                      | 3    | Shock and suction valves at A and B or A or B (state pressure in bar)  |
| /3 A... B...<br>/3 A...<br>/3 B...   | G 1                   | --                                 | 3    | Shock valves at A and B or A or B (state pressure in bar)  |
| /5 S   | G 1/2                 | --                                 | 3    | Load signal pick-up ports U and W (G 1/4) for external circuitry   |
| /53, /533  | G 1/2                 | --                                 | 5    | Sub-plate for valve section size 3 in a valve bank size 5 (saving an intermediate plate)                                     |
| /534   | G 3/4                 | --                                 | 5    |  |
| /58  | G 1                   | --                                 | 5    |  |
| /3 X, /UNF 3 X,<br>/UNF 4 W  | G 1/2                 | 7/8-14 UNF-2B<br>(1 1/16-12UNF-2B) | 3    | Joint load signal pick-up port X for external circuitry  |
| /4 X   | G 3/4                 | --                                 | 3    |  |
| /5 X   | G 1                   | --                                 | 5    |  |
| /5 SAE, /5 SAE S,<br>/5 SAE 8  | SAE 1" (6000 psi)     |                                    | 5    | Sub-plate with SAE-flange, analogue /5, /5 S and /58   |
| /6D SAE  | SAE 1 1/4" (6000 psi) |                                    | 5    | Sub-plate with SAE-flange for combination of two valve sections, to achieve a load compensated consumer flow of max. 400 lpm |
| /Z AN..BN..  | --                    |                                    | 5    | Intermediate plate with shock and suction valves   |

**Note:** Sub-plate with SAE-flange must not be combined with sub-plates (tapped ports) e.g.

Symbols

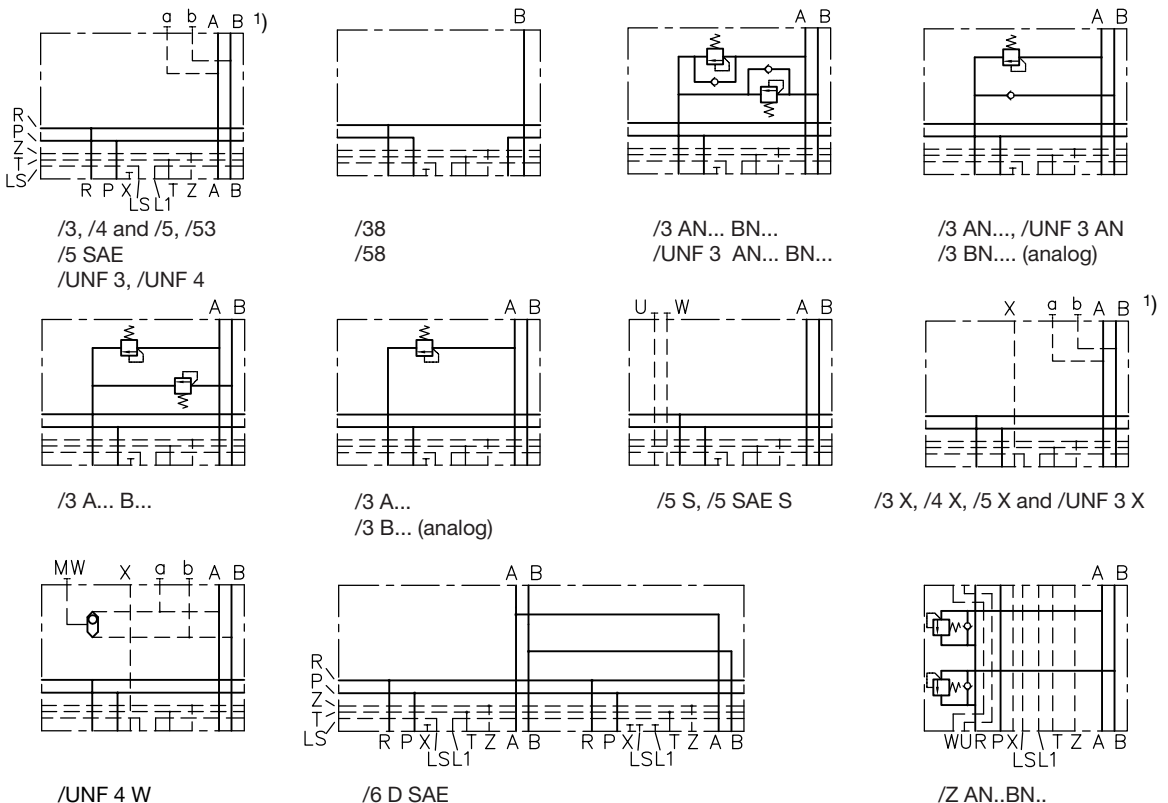

## 4. Characteristic data

### 4.1 General and hydraulic

|                            |  |  |                   |  |   |   |
|----------------------------|--|--|-------------------|--|---|---|
| Type coding                | PSLF, PSVF and SLF   |  |                   |  |   |   |
| Design                     | Directional spool valve for manifold mounting, up to 12 spool valves may be combined in a valve bank by means of sub-plates, all-steel design  |  |                   |  |   |   |
| Mounting                   |  | Size 3   | Size 5            | See dimensional drawings in sect. 5 ++ |   |   |
|                            | Indiv. section   | 4 x M8   | 4 x M10           |  |   |   |
|                            | Valve bank   | M8   | M10               |  |   |   |
| Installation position      | Any  |  |                   |  |   |   |
| Ports                      | P  | = Pressure inlet (pump)  |                   |  |   |   |
|                            | R  | = Return   |                   |  |   |   |
|                            | A, B   | = Consumer ports   |                   |  |   |   |
|                            | U, W, X  | = Load-signal outlet at the indiv. spool valve section               |                   |  |   |   |
|                            | LS   | = Load-signal outlet e.g. connection of pump metering valve at PSVF. |                   |  |   |   |
|                            |  | <b>Attention:</b> No pressure input!                                 |                   |  |   |   |
|                            | M  | = Pressure gauge connection (pump side)                              |                   |  |   |   |
|                            | Z  | = Pilot pressure connection (20...40 bar inlet, 20 or 40 bar outlet) |                   |  |   |   |
|                            | T  | = Control oil return port  |                   |  |   |   |
|                            | Y  | = Load-signal inlet port (end plate E 2 and E 5)                     |                   |  |   |   |
| Port size                  | P, R, A, B   | = Acc. to dimensional drawings (see sect. 5.10)                      |                   |  |   |   |
|                            | M, LS, Z, T, Y   | = G 1/4 conform. ISO 228/1 (BSPP)                                    |                   |  |   |   |
|                            | U, W, X  | = Acc. to dimensional drawings (see sect. 5.9 and 5.10)              |                   |  |   |   |
| Surface coating            | Indiv. valve section and sub-plates: All surfaces corrosion-inhibiting, gas nitrided (Solenoid at actuation E... and additional functions F1...F 3, FP 1...FP 3, FPH 1...FPH 3 inc galvanized and olive-green anodized)  |  |                   |  |   |   |
| Mass (weight) approx. (kg) | Size   |  | 3                 | 5                                      |   |   |
|                            | Inlet section  | PSLF, PSVF../., PSVF..-  | 3.8 <sup>1)</sup> | 3.3 <sup>1)</sup>                      |   |   |
|                            | Valve section  | Actuation  | A, E, F, H, P     | 4.4 <sup>2)</sup>                      | 6.6 <sup>2)</sup>   | 1) + 0.6 kg at version with solenoid valve WN1F(D), PA...PD acc. to table 8 |
|                            |  |  | EA, PA            | 4.8 <sup>2)</sup>                      | 7.0 <sup>2)</sup>   |   |
|                            |  |  | FA, HA            | 4.7 <sup>2)</sup>                      | 6.6 <sup>2)</sup>   |   |
|                            |  |  | FEA, HEA          | 5.1 <sup>2)</sup>                      | 7.1 <sup>2)</sup>   |   |
|                            | Blanking plate   | AX   | 0.9               | ---                                    |   |   |
|                            | Intermediate plate   | /Z AN..BN..  | --                | 3.1                                    | 2) + 0.4 kg at version with functional cut-off (coding F.., FP.., FPH.. acc. to table 16) |   |
|                            | Sub-plates   | /3, /38, /4, /5, /53, /533, /534, /5 S, /3 X, /5 X, /6               | 2.2               | 4.3                                    |   |   |
|                            |  | /3 AN... BN..., /3 A..B..  | 2.5               | ---                                    |   |   |
|                            |  | /5 SAE, /5 SAE S, /5 SAE 8   | --                | 9.2                                    |   |   |
|                            |  | /6 D SAE   | --                | 17.0                                   |   |   |
|                            |  |  |                   |  |   |   |
| End plates                 | E 1, E 2, E 4, E 5   | 0.8  | 1.8               |  |   |   |
|                            | E 3 and E 6  | 2.1  | 3.1               |  |   |   |
|                            | E 7, E 8, E 9, E 10  | 2.0  | ---               |  |   |   |
|                            | E 1 SAE ... E 5 SAE  | --   | 2.9               |  |   |   |
| Adapter plate              | ZPL 53, ZPL 5 SAE 3  | 5.0  |                   |  |   |   |
| Pressure fluid             | Hydraulic fluid (DIN 51524 table 1 to 3); ISO VG 10 to 68 (DIN 51519)<br>Viscosity range: min. 4; max. 1500 mm <sup>2</sup> /sec; Optimal operation range: 10...500 mm <sup>2</sup> /sec<br>Also suitable are biodegradable pressure fluids of the type HEPG (Polyalkylenglycol) and HEES (synth. Ester) at operation temperatures up to +70°C. HETG (e.g. rape seed oil) or water based fluids e.g. HFA or HFC must not be used!  |  |                   |  |   |   |
| Temperature                | Ambient: approx. -40 ... +80°C; Fluid: -25 ... +80°C, pay attention to the viscosity range!<br>Start temperature down to -40°C are allowable (Pay attention to the viscosity range during start!), as long as the operation temperature during consequent running is at least 20K (Kelvin) higher.<br>Biodegradable pressure fluids: Pay attention to manufacturer's information. With regard to the compatibility with sealing materials do not exceed +70°C.<br><b>Restriction for version with ex-proof solenoid:</b><br>Ambient: -35 ... +40°C; Fluid: max. 70°C max. 70°C for version G 24 EX 70 Ambient: -35...+70°C, Fluid: max. 75°C |  |                   |  |   |   |
| Rec. contamination class   | ISO 4406 18/14   |  |                   |  |   |   |
| Operating pressure         | p <sub>max</sub> = 400 bar; Ports P, P1, A, B, LS, M, Y  |  |                   |  |   |   |
|                            | The max. pressure achievable at the consumer side of the spool valves is lowered by the amount equivalent to the internal control pressure drop at the 3-way flow regulator of the PSLF (see curves) or at the pump flow regulator (PSVF)..  |  |                   |  |   |   |
|                            | Return port R(R1) ≤ 50 bar; port T pressure less with separate pipe (e.g. 6x1) to the tank. It is recommended to employ end plate E 1, E 2, E 3, etc. with an additional leakage port, in case higher return pressure is anticipated. Port Z approx. 20 or 40 bar (acc. to coding, see table 7) (outlet); ≤ 40 bar (inlet)   |  |                   |  |   |   |
| Control circuit            | For control pressure, see Q-I-characteristics. The internal control oil circuit is sufficiently protected against malfunctions caused by contamination by means of a disk filter.  |  |                   |  |   |   |
| Flow                       | Acc. to the specifications in table 14, in sect. 3.2.1   |  |                   |  |   |   |

### 4.2 Curves

Main pressure limiting valve in the inlet section

PSL(V)F A../.-3

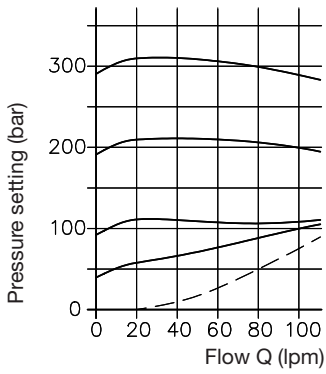

PSL(V)F A../.-5

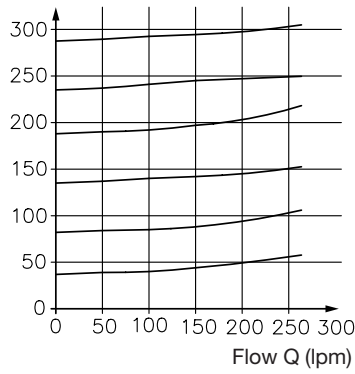

Inlet section PSLF A..

Circulation pressure P→R

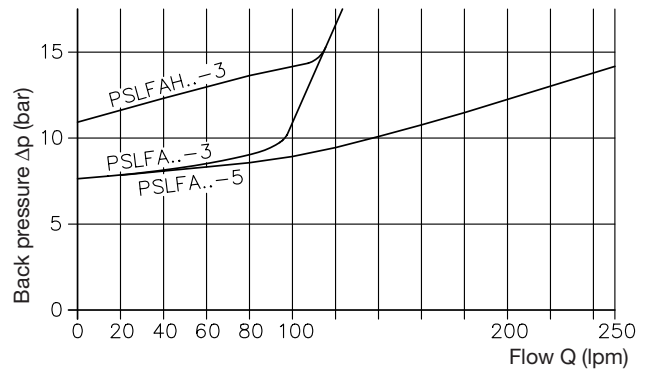

Directional spool valve section P→A(B), A(B)→R  
Size 3 Size 5

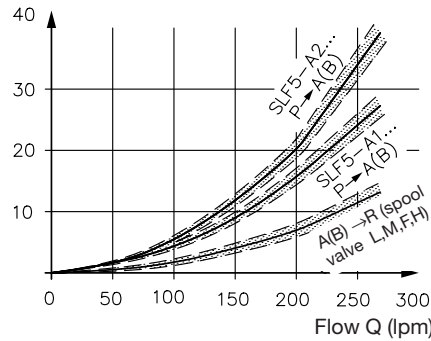
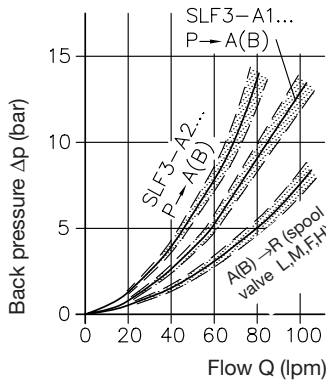

Prop. pressure limitation

Coding PA ... PD acc. to table 8, sect. 3.1.3  
Coding FP(H) 1, FP(H) 2, FP(H) 3  
acc. to table 16, sect. 3.2.1

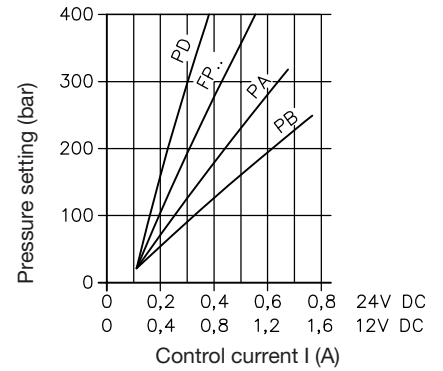

2-way inflow controller

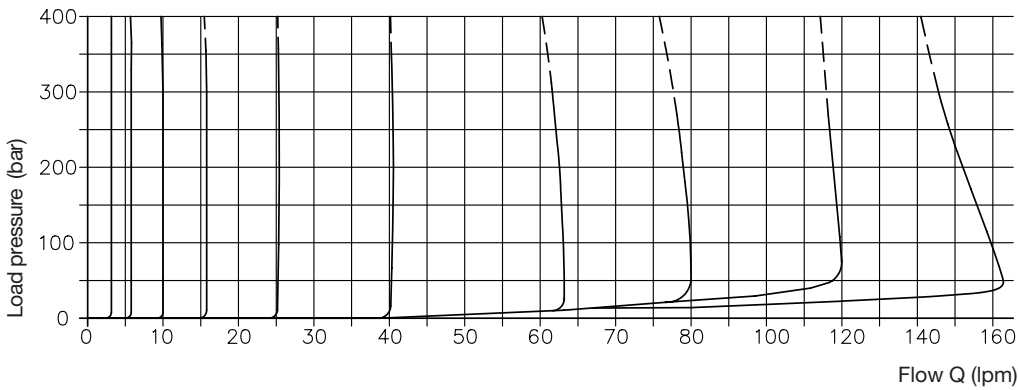

Oil viscosity during measurement approx.  
60 mm<sup>2</sup>/sec

Consumer flow curves (guide line, example is valve section with inflow controller type SLF - A2 ../.)

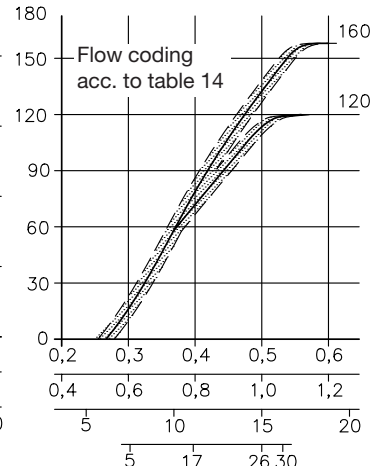
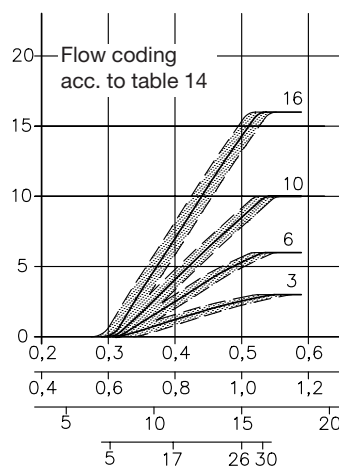
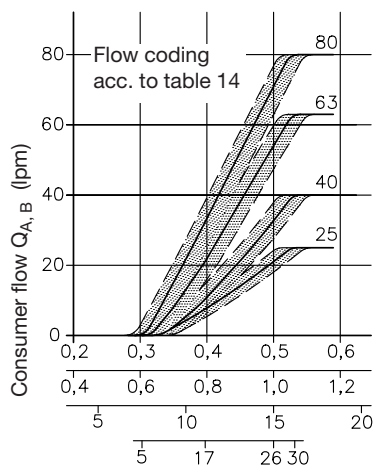

- ← Control current I (A)  
24 V DC
- ← Control current I (A)  
12 V DC
- ← Control pressure (bar)  
hydr. actuation H, F
- ← Angle at hand lever (°)  
manual actuation A, C

### 4.3 Actuators

For other data, such as codings, symbols etc., see table 18 sect. 3.2

|                                      |   |   |
|--------------------------------------|---|---|
| Actuation A                          | Actuating moment (Nm) size 3 / 5  |   |
|                                      | Idle position   | End position  |
|                                      | Version A<br>Version FA, FEA, HA, HEA, PA<br>Version EA, E0A  | approx. 2.3 / 3.0<br>approx. 2.9 / 5.0<br>approx. 2.4 / 3.0 |
| Actuation C<br>AC, EC, EAC           | Version with detent, fixation of the valve spools at any desired position (idle position with special notch)<br>Version with detent, fixation of the valve spool at idle and both end positions<br>Required pulse duration for switching: approx. 1 sec |   |
| Actuation<br>E, EA, HE, HEA, FE, FEA | Prop.-Solenoid, manufactured and tested acc. to VDE 0580<br>Twin solenoids are of wet armature design. The hydraulic fluid provides lubrication and protection against corrosion.   |   |

**Additional notes:**

See also Sk 7814, as well as for additional components sect. 6.1 j!

Specifications apply to all solenoid versions if not stated otherwise.

|   |                           |               |
|---|---------------------------|---------------|
| Nom. voltage $U_N$  | 24 V DC                   | 12 V DC       |
| Coil resistance $R_{20}$  | 26.6 $\Omega$             | 6.3 $\Omega$  |
| Current, cold $I_{20}$  | 0.9 A                     | 1.9 A         |
| Lim. current $I_G$ ( $I_{lim}$ )  | 0.63 A                    | 1.26 A        |
| Cut-off energy $W_A$  | $\leq 0.3$ Ws             | $\leq 0.3$ Ws |
| Rel. duty cycle<br>(reference temp. $\vartheta_{11} = 50^\circ\text{C}$ ) | S 1                       | S 1           |
| Protection class (assembled)  | 40...70Hz<br>(best 55 Hz) |               |
| Dither amplitude $A_D$ <sup>1)</sup>                                      | $20\% \leq A_D \leq 35\%$ |               |

$$1) A_D (\%) = \frac{I_{\text{peak-peak}}}{I_G} \cdot 100$$

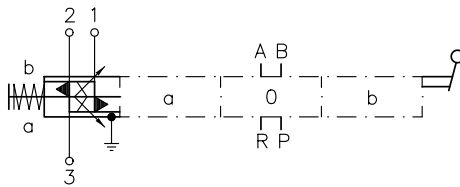
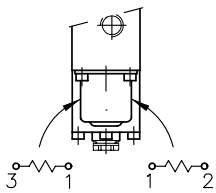

Oil viscosity during measurement approx. 60 mm<sup>2</sup>/s

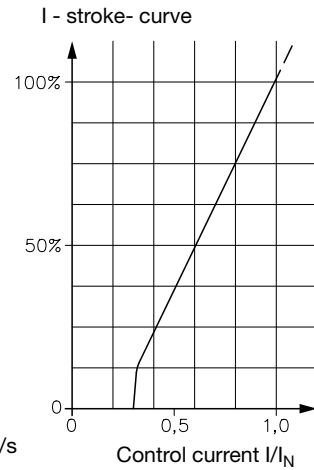

**Electrical connection**

Circuitry for coding ..-G 12(24)  
..-X 12(24)  
EN 175 301-803 A  
IP 65 (IEC 60529)  
(standard version)

Circuitry for coding EB, EAB  
IP 67 (IEC 60529)

Coil a    Coil b

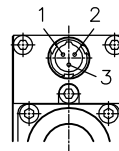
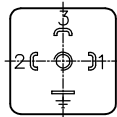
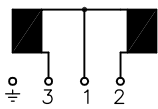

Circuitry for coding -AMP 24 H 4  
AMP Junior Timer,  
4-polig  
IP 65 (IEC 60529)

Circuitry for coding ..-G 24 H 4,  
4-polig  
IP 65 (IEC 60529)

Circuitry for coding ..-G 24 C 4,  
4-polig  
EN 175 301-803 C  
IP 65 (IEC 60529)

Coil a    Coil b

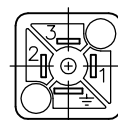
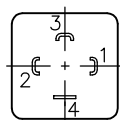
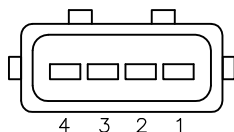
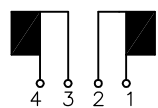

The IP-specification only applies when the plug is mounted as specified.

Explosion-proof version of actuation E, EA  
Voltage specification **G 24 EX**

**Attention :**

Additionally observe operating manuals  
B 01/2002 and B ATEX

Protect against direct sun light !

Not in to combination with functional cut-off  
F(FP).. (table 17) or all other solenoids mounted  
on connection blocks (table 3 a, 8), ancillary  
blocks (table 19), intermediate plates (table 22)  
and end plates (table 11)

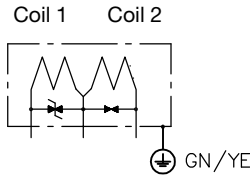

|                               |   |
|-------------------------------|---|
| Certificate of conformity     | TÜV-A 02ATEX 0007 X   |
| Ex-proof level                | ⊕ II 2 GD T120°C IP67 EEx m II 120°C (T4)   |
| Duty cycle                    | S 1, one coil energized per solenoid housing  |
| Protection class              | IP 67 (IEC 60529)   |
| Nom. voltage $U_N$            | 24 V DC   |
| Coil resistance $R_{20}$      | 26.6 $\Omega$   |
| Current, cold $I_{20}$        | 0.88 A  |
| Lim. current $I_G$            | 0.63 A  |
| Max. residual ripple of the   | 15% supply voltage  |
| Conditions of use:            |   |
| Max. ambient temperature      | +40°C   |
| Max. fluid temperature        | +70°C   |
| Fuse                          | $I_F < 1.8$ A each solenoid must be safe guarded<br>against overload and short-cut by fuse conforming<br>IEC 60127 medium |
| Surface coating               | Housing zinc galvanized<br>Coil and connection cavity are molded  |
| Electrical design and testing | conforming EN 50014, VDE 0170/0171 T 1 and T 9  |
| Electrical connection         | 4 x 0.5 mm <sup>2</sup>   |
| Cable length                  | 3 m or 10 m (cable ÖLFLEX-440P ® Co. Lapp,<br>D-70565 Stuttgart)  |
| For connection scheme. see    | "Actuation E, EA" (standard version)  |

Explosion-proof version of actuation E, EA, HE(A)  
Voltage specification **G 24 EX 70**

**Attention:**

Additionally observe operating manuals  
B 01/2002 und B ATEX

Protect against direct sun light !

Not in to combination with functional cut-off  
F(FP).. (table 17) or all other solenoids mounted on  
connection blocks (table 3 a, 8), ancillary blocks  
(table 19), intermediate plates (table 22) and end  
plates (table 11)

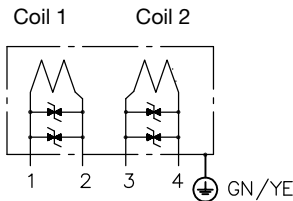

|                               |   |
|-------------------------------|---|
| Certificate of conformity     | IBExU07ATEX 1089 X  |
| Ex-proof level                | ⊕ II 2G Ex d II B T4<br>⊕ II 2D Ex tD A21 T135°C  |
| Duty cycle                    | S 1, one coil energized per solenoid housing  |
| Protection class              | IP 67 (IEC 60529)   |
| Nom. voltage $U_N$            | 24 V DC   |
| Coil resistance $R_{20}$      | 80 $\Omega$   |
| Lim. current $I_G$            | 0.24 A  |
| Max. residual ripple of the   | 15% supply voltage  |
| Conditions of use:            |   |
| Max. ambient temperature      | +70°C   |
| Max. fluid temperature        | +75°C   |
| Fuse                          | $I_F < 0.5$ A each solenoid must be safe guarded<br>against overload and short-cut by fuse conforming<br>IEC 60127 medium |
| Surface coating               | Housing zinc galvanized<br>Coil and connection cavity are molded  |
| Electrical design and testing | conforming, EN 50014, VDE 0170/0171 T 1 and T 9   |
| Electrical connection         | 4+1 x 0.5 mm <sup>2</sup>   |
| Cable length                  | 3 m or 10 m (cable ÖLFLEX-440P ® Co. Lapp,<br>D-70565 Stuttgart)  |

Actuation suffix E, EA, HE(A)  
Explosion-proof version of actuation  
(intrinsic safe, flame proof )  
Voltage specification **G 12 IS**

Protect against direct sun light !

Not in to combination with functional cut-off  
F(FP).. (table 17) or all other solenoids mounted on  
connection blocks (table 3 a, 8), ancillary blocks  
(table 19), intermediate plates (table 22) and end  
plates (table 11)

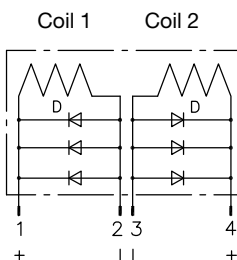

|  |  |
|--|--|
| Certificate of conformity  | IBExU05ATEX 1116 X   |
| Ex-proof level   | ⊕ I M2 Ex d ib I   |
| Duty cycle   | S 1, one coil energized per solenoid housing   |
| Protection class   | IP 67 (IEC 60529)  |
| Nom. voltage $U_N$   | 12 V DC  |
| $I_l$  | 1.7 A  |
| Lim. current $I_G$   | 0.4 A  |
| Coil resistance $R_{20}$   | 22 $\Omega$  |
| Conditions of use:   |  |
| Max. ambient temperature   | +40°C  |
| Max. fluid temperature   | +70°C  |
| Surface coating  | Housing zinc galvanized<br>Coil and connection cavity are molded   |
| Electrical design and testing                                    | conforming EN 60079-0 (general requests),<br>EN 50020 (intrinsic safe "i"),<br>EN 60079-1 (pressure resistant encapsulation "d") |
| Electrical connection  | 4 x 0.5 mm <sup>2</sup>  |
| Cable length   | 3 m or 10 m (cable ÖLFLEX-EB ® Co. Lapp,<br>D-70565 Stuttgart) Coded leads: 1-4,<br>insulation color: fair blue)                 |
| The complete circuit has to be designed and get approved acc. to | EN 60079-25.   |

**Note:** Due to the utilized clamp diodes at the pulsed prop. amplifier PWM it is not possible to measure the coil current during operation. Readings will usually be too low and are additionally dependent on the supply voltage and the coil resistance.

**Attention:** Take polarity into account!

Actuation suffix E, EA, HE(A) (flame proof)  
Voltage specification **G 24 MSHA**

**Attention:**

Additionally observe operating manuals  
B 05/2003 and B ATEX

|                                |   |
|--------------------------------|---|
| MSHA-approval (USA)            | 18-NXA 05 0003-0  |
| MA-approval (China)            | J2007101  |
| ATEX-Certificate of conformity | IBExU05ATEX 1115 X  |
| Ex-proof level                 | ⊕ M2 Ex d I   |
| Duty cycle                     | S 1, one coil energized per solenoid housing  |
| Protection class               | IP 67 (IEC 60529)   |
| Nom. voltage $U_N$             | 12 V DC                      24 V DC  |
| Coil resistance $R_{20}$       | 6.3 $\Omega$ 26.6 $\Omega$  |
| Lim. current $I_G$             | 1.33 A                      0.63 A  |
| Current. cold $I_{20}$         | 1.9 A                      0.9 A  |
| Conditions of use:             |   |
| Max. ambient temperature       | +40°C   |
| Max. fluid temperature         | +70°C   |
| Fuse                           | I = max. 3x $I_G$ , each solenoid must be safe guarded against overload and short-cut by fuse conforming IEC 60127-2 UL 248 |
| Surface coating                | Housing zinc galvanized<br>Coil and connection cavity are molded  |
| Electrical design and testing  | conforming EN 60079-0 (general requests), EN 60079-1 pressure resistant encapsulation "d"                                   |
| Electrical connection          | 4 x 18 AWG (approx. 0.8 mm <sup>2</sup> )   |
| Cable length                   | 3 m or 10 m   |
| Leads                          | BK, WH, RD, GN; Item-Nr. 40003, General Cable   |

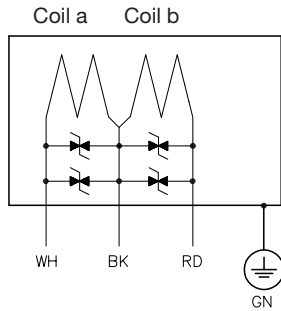

Actuation suffix H, HA, HEA, F, FA, FEA

Control pressure approx. 5 bar (start of movement)  
approx. 18 bar (max. movement) max. perm. pressure 50 bar  
The remote control pipes to the control ports 1 and 2 must be externally piped.  
Supply is via proportional pressure reducing valve e.g. type FB2/18 etc. or KFB2/18 (both acc. to D 6600)

Actuation suffix P, PA

Control pressure approx. 2.5 bar (start of movement);  
approx. 7 bar (max. movement)

Actuation suffix V, VA, VB, VC  
(only size 3)

The idle position of the valve spool is monitored by a contact switch from Co. Burgess @ type V 4 NS with lever AR 1  
Switch engaged at idle position  
Protection class IP 67 (IEC 60529)  
Circuit-breaking capacity up to = 5 A  
Inductive load = 3 A  
Cables 3 x 0.5 mm<sup>2</sup> Litze PVC coated; length; 50 mm  
black = inlet  
blue = NO-contact  
green = NC-contact  
The switch is highly protected by a sheet cover against exterior physical damage

Actuation suffix VCHO, VCHC  
(only size 3)

The idle position of the valve spool is monitored by a contact switch from Co. Burgess @ type V 4 N 4 Sk 2 with lever AR 1  
Switch engaged at idle position  
Electr. connection via plug, e.g. type G 4 W 1 F @ Co. Hirschmann, www.hirschmann.com, (not scope of delivery)  
Protection class IP 65 (IEC 60529)  
Circuit-breaking capacity up to 30 V DC = 5 A  
Inductive load = 3 A

Circuitry

VCHO

VCHC

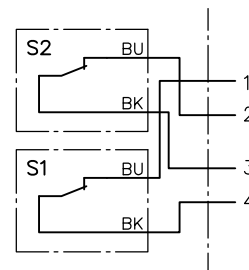
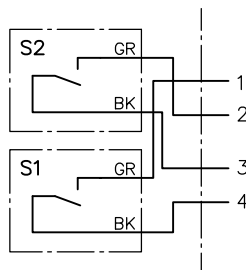
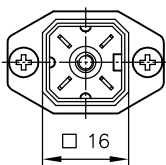

Switch function  
S 1 - direction A  
S 2 - direction B

Actuation suffix N  
(only size 3)

Supervision of the idle position of the valve spool via a transducer  
 Design 8x8x40mm, with LED-display, e.g. NC-contact, conducting to plus an even type IFFM 08P/37O1/02L  
 Manufacturer: Co. BAUMER Electric GmbH D-61169 Friedberg  
 Input power  $\varnothing$ 3 mm, 3 leads PVC coated, length 2 m  
 Operating voltage 10 up to 30 V DC  
 Current consumption without load up to 10 mA  
 Max. load current 200 mA  
 Operating temperature -25°C up to 80°C  
 Protection class IP 67 (IEC 60529)  
 The switch is highly protected by a sheet cover against exterior physical damage.

Actuation suffix WA.  
WA-EX n

Transducer, supervision of the valve spool stroke via a displacement transducer (Hall-sensor)

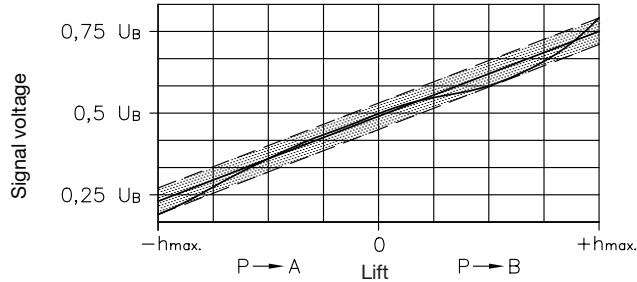

$U_B$  = Supply voltage  
 $U_{Bmax}$  = 76%  
 $U_{Bmin}$  = 24%  
 Accuracy  $\pm$  9% ( $U_B$ )

Circuitry  
WA

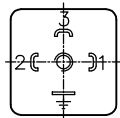

2 =  $+U_B$  operating voltage (5 up to 10V)  
 1 =  $U_{output}$   
 3 = GND

The DC supply voltage must be stabilized and smoothened. **Attention:** The transducer will be permanently damaged, when exposed to a strong magnetic field !

Actuation suffix WA

Electrical connection EN 175 301-803 A  
 Protection type (assembled) IP 65 (IEC 60529)

Actuation suffix WA-EX n

Ex-proof level  $\text{Ex II 3 G IP 65 Ex nA II T 4 X}$   
 $\text{Ex II 2 GD c T 4}$

Electrical connection 3 m or 10 m (cable ÖLFLEX-440 ® Co. Lapp, D-70565 Stuttgart)

Actuation suffix WA-EX n: Operating manual B ATEX and B ATEX-WA-EX n have to be additionally regarded!

Actuation suffix U  
(only size 3)

Comparator  
(lift monitoring / side indication)

Circuitry

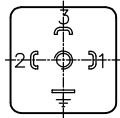

| Pin | Signal           | Description                        |   |
|-----|------------------|------------------------------------|---|
| 1   | OUT <sub>A</sub> | PNP-transistor conducting to plus) | Open-Collector:<br>$I_{max} = 10 \text{ mA}$<br>short-circuit proof |
| 2   | OUT <sub>B</sub> | PNP-transistor conducting to plus) |   |
| 3   | $+U_B$           | 10 ... 32 V DC                     | Residual ripple $\leq$ 10%  |
| GND | GND              | 0 V DC                             |   |

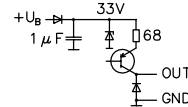

Electrical connection

EN 175 301-803 A

#### 4.4 Functional cut-off, prop. pressure limitation

Functional cut-off

On/Off solenoid with manual emergency actuation

|                               |               |               |
|-------------------------------|---------------|---------------|
| Nom. voltage $U_N$            | 24 V DC       | 12 V DC       |
| Coil resistance $R_{20}$      | 34.8 $\Omega$ | 8.7 $\Omega$  |
| Current, cold $I_{20}$        | 0.69 A        | 1.38 A        |
| Current, warm $I_{70}$        | 0.48 A        | 0.97 A        |
| Cut-off energy $W_A$          | $\leq$ 0.3 Ws | $\leq$ 0.3 Ws |
| Rel. duty cycle <sup>1)</sup> | S 1           | S 1           |

Electrical connection EN 175 301-803 A  
 Protection type (assembled) IP 65 (IEC 60529)

Circuitry

Coil a      Coil b

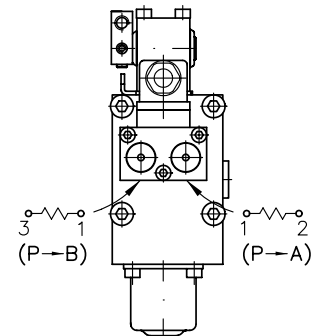
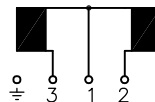
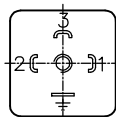

<sup>1)</sup> **Note:** The duty cycle refers to one coil only of each twin solenoid. The perm. duty cycle is only 50%, when both coils are energized simultaneously

Prop. pressure limitation

Prop. solenoid, with manual emergency actuation. For connection pattern, see functional cut-off. For electrical data, see actuation E, EA.

### 4.5 Other solenoid valves

|                          |                                     |         |   |         |                                       |         |
|--------------------------|-------------------------------------|---------|---|---------|---------------------------------------|---------|
| Electrical data          | - Connection blocks coding Z, ZM, V |         | - Connection blocks coding F, D<br>- End plates coding E 3, E 6 |         | - Connection blocks coding PA, PB, PD |         |
| Additional documentation | D 7490/1 E (type EM)                |         | D 7470 A/1 (type WN 1, WH 1)                                    |         |                                       |         |
| Nom. voltage $U_N$       | 24 V DC                             | 12 V DC | 24 V DC   | 12 V DC | 24 V DC                               | 12 V DC |
| Nom. power $P_N$         | 21 W                                | 21 W    | 24.4 W  | 24.4 W  | 21 W                                  | 21 W    |
| Nom. current $I_N$       | 0.63 A                              | 1.2 A   | 1 A   | 2 A     | 0.63 A                                | 1.26 A  |

#### Electr. connection

Circuitry with coding  
-G 12, -G 24,  
-X 12, -X 24  
  
EN 175 301-803 A  
IP 65 (IEC 60529)

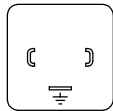

Circuitry with coding  
-S 24  
  
Plug Co. Schlemmer  
Type SL-10  
IP 67 (IEC 60529)

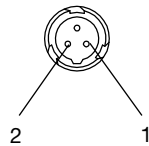

Circuitry with coding  
-AMP 24 H 4  
  
AMP Junior Timer  
2-pin  
IP 65 (IEC 60529)

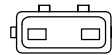

Circuitry with coding  
with PA, PB, PD  
-G 12, -G 24, -X 12, -X 24  
  
Slim design industrial  
standard contact  
clearance 11 mm  
IP 65 (IEC 60529)

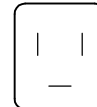



**Type PSL..F(D)/...  
PSV..F(D)  
PSV..F(D)/...**

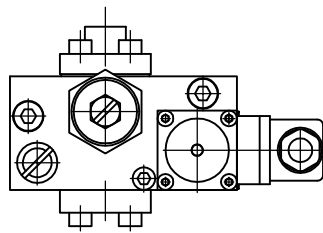
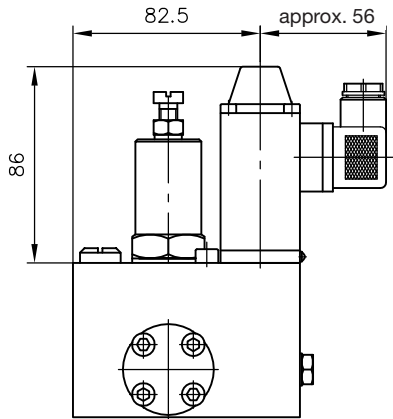

**Type PSL..F(D).../...  
PSV..F(D).../...**

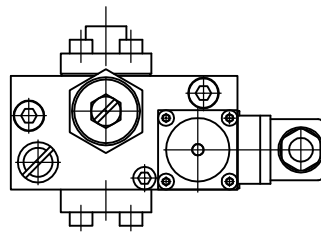
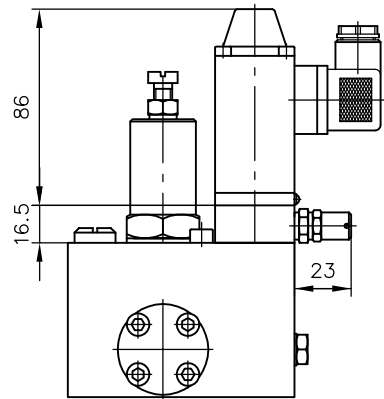

**Type PSV...X...**

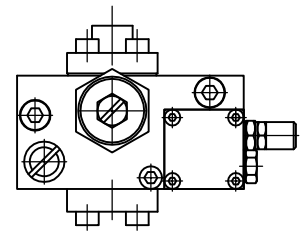
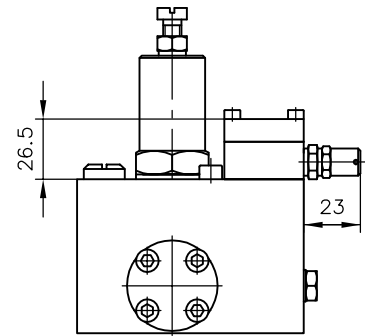

**Type PSL..PA(PB, PD)/...  
PSV..PA(PB, PD)**

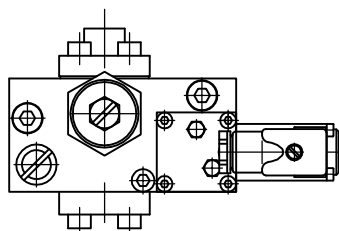
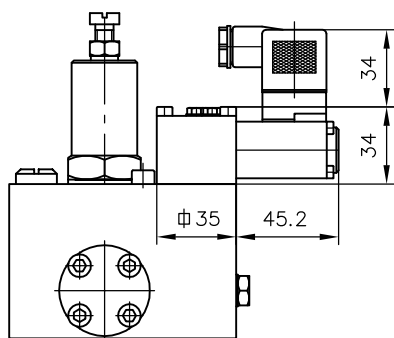

**Type PSL..Z(V).../...  
PSV..Z(V).../...**

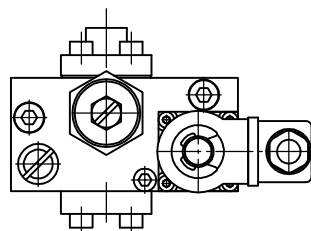
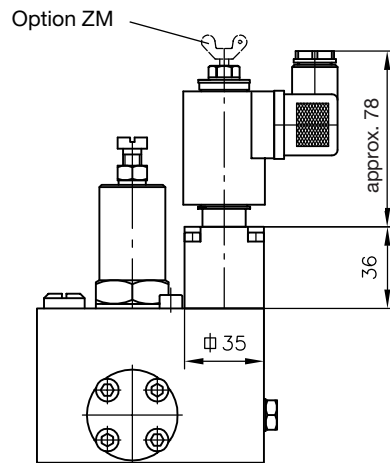

5.1.3 Individual valve with manual actuation type A, C

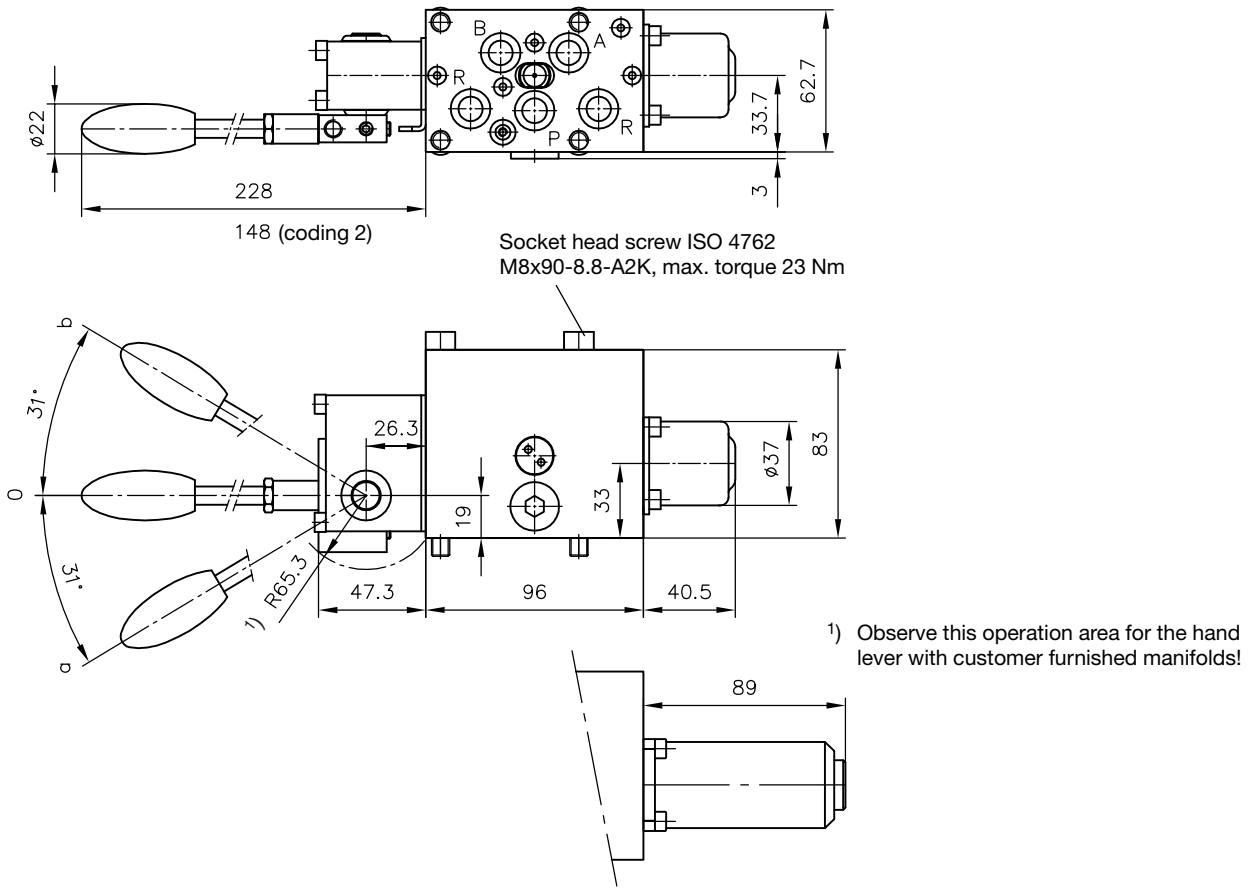

5.1.4 Individual valves with actuation type EA, E0A

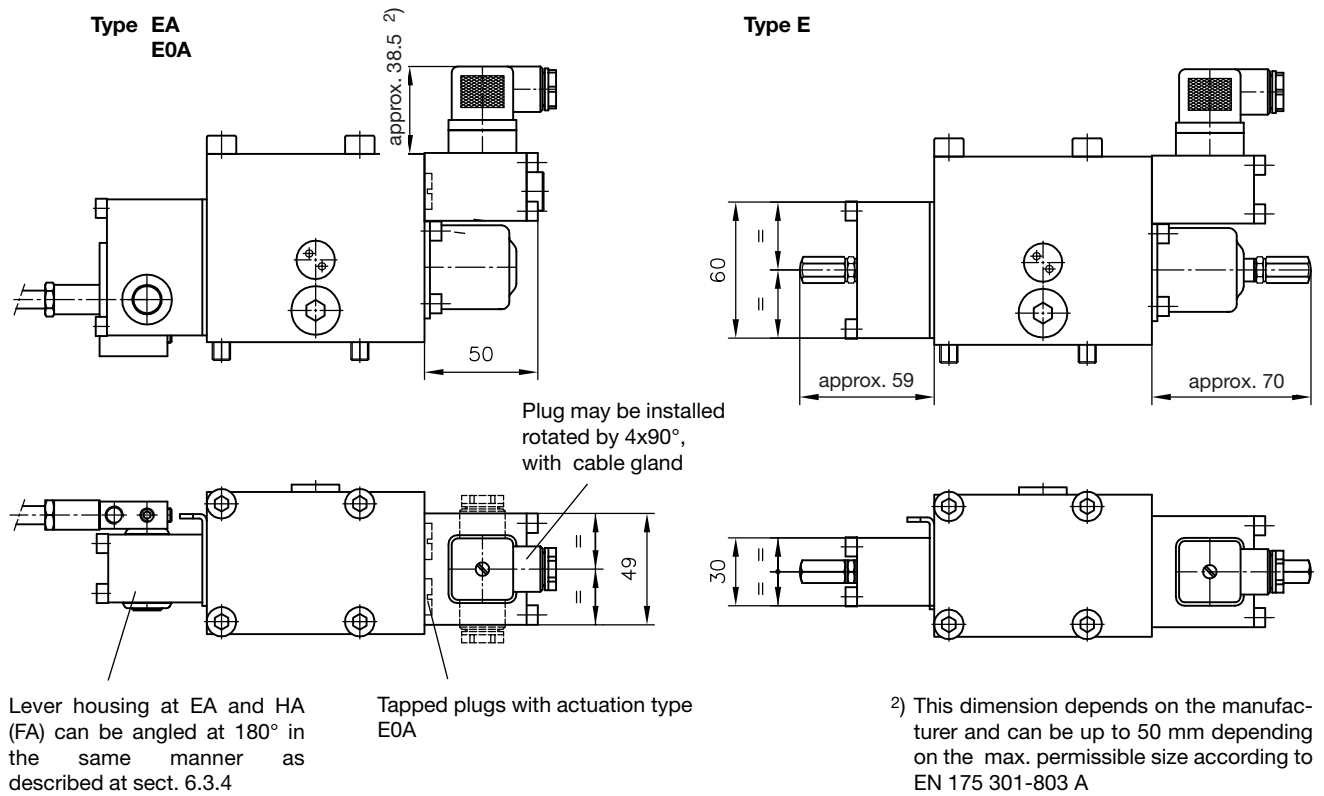

Further versions

Actuation type **EB, EAB**

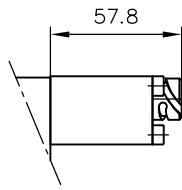

Actuation type **EBT, EABT**

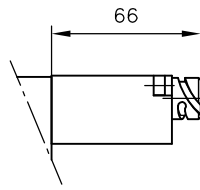

Actuation type **E(EA)...-AMP H 4**

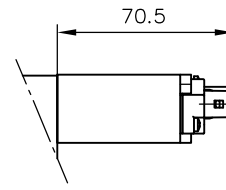

Actuation type **ET, EAT, ETH, EATH**

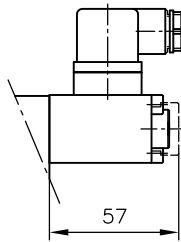

Actuation type **E(EA)...-G(X) 24 C 4**

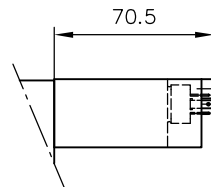

Actuation type **E(EA)...-G 24 EX**

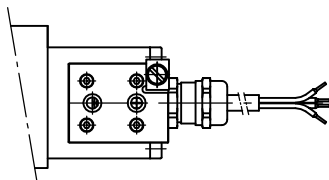
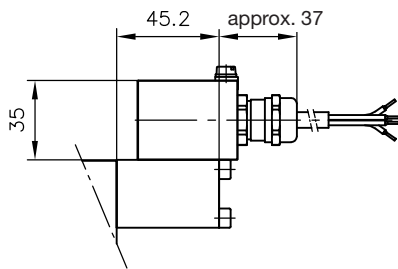

Actuation type **E(EA) -G 12 IS  
-G 24 MSHA**

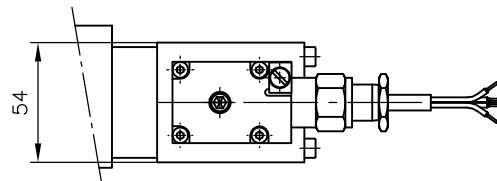
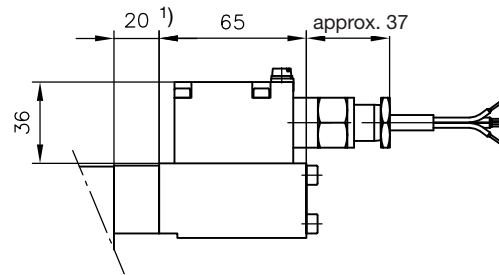

Actuation type **E(EA)...-G 24 EX 70**

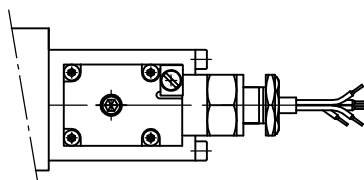
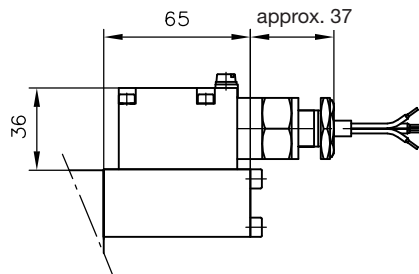

1) Intermediate plate only in combination with actuation type EC and EAC

5.1.5 Individual valves with hydraulic actuation type FA, FEA, F

Type FA

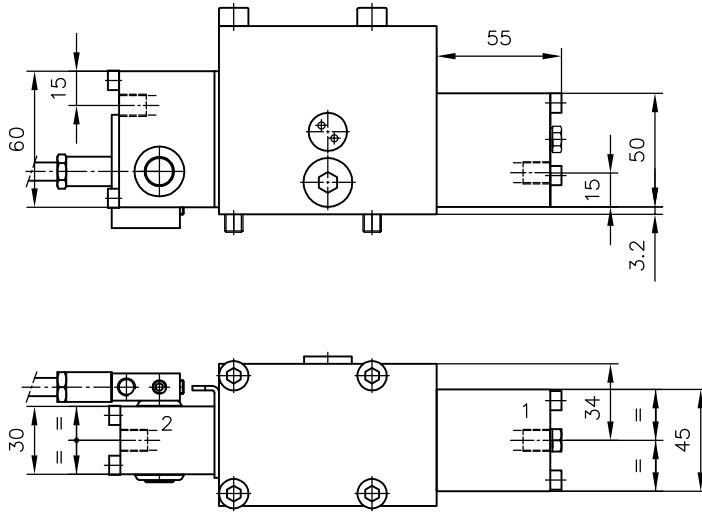

Type FEA, FEA 1(2)

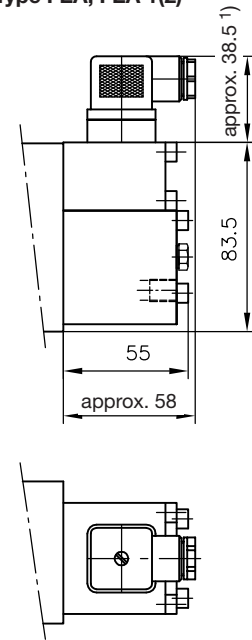

Type F

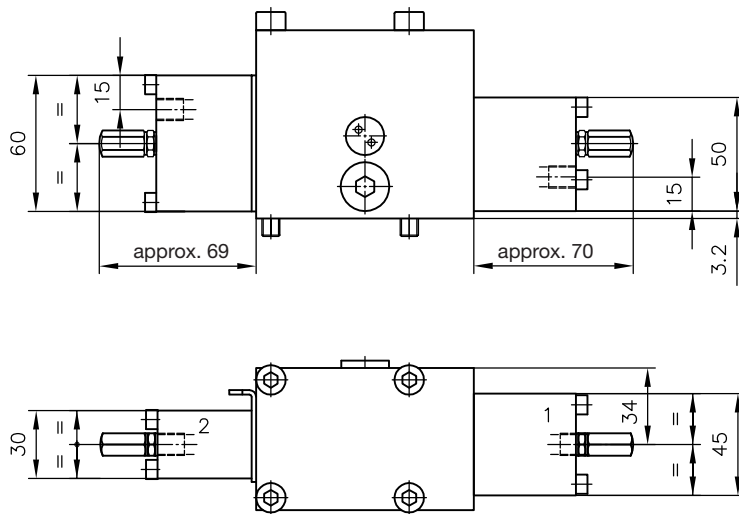

Ports conf. ISO 228/1 (BSPP) or (SAE-4, SAE J 514):  
1 and 2 = G 1/8 or 7/16-20 UNF-2B

1) This dimension depends on the manufacturer and can be up to 50 mm depending on the max. permissible size according to EN 175 301-803 A Plug may be installed rotated by 4x90°, with cable gland

**5.1.6 Individual valves with pneumatic actuation type PA and P**

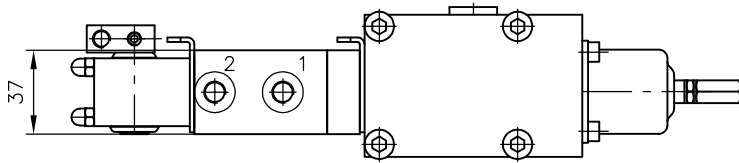
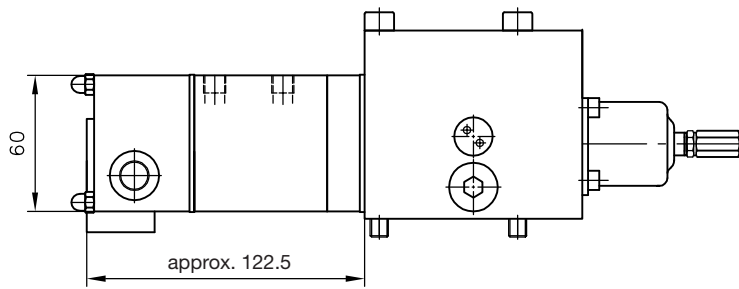

Ports conf. ISO 228/1 (BSPP):  
1 and 2 = G 1/8

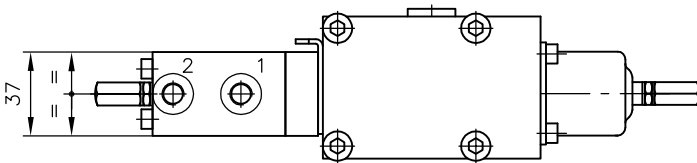
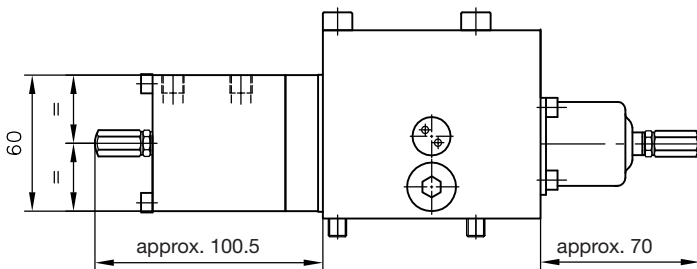

**5.1.7 Blanking plate type AX**

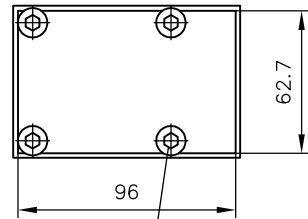
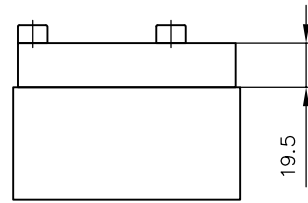

Mounting screw  
4 x socket head screw  
ISO 4762-M8x25 - 8.8-A2K, 23 Nm

**5.1.8 Lift monitoring**

Type ... N(1)

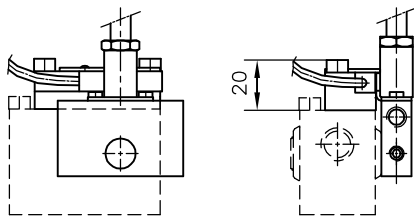

Type ... WA, U

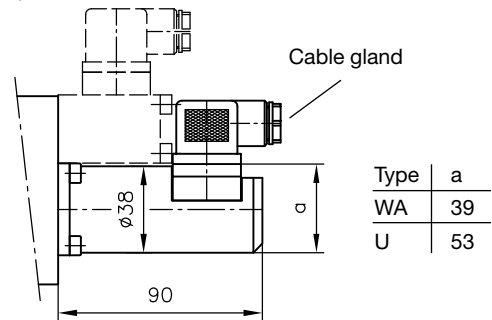

Type ... V (VA, VB, VC)

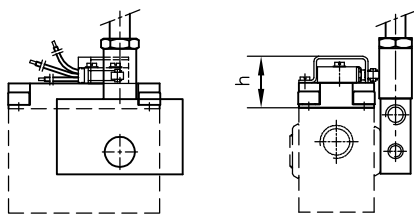

| Type           | h    |
|----------------|------|
| ... V (VA, VB) | 20.5 |
| ... VC         | 27   |

Type WA-EX n

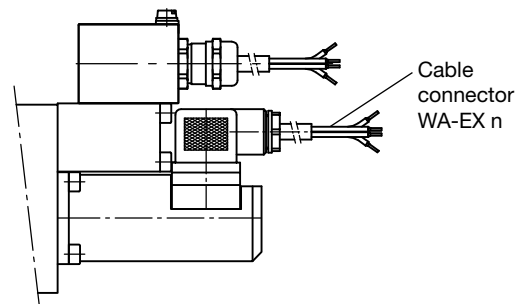

5.1.9 Valve sections with secondary pressure limitation, functional cut-off and prop. pressure limitation

Type A..

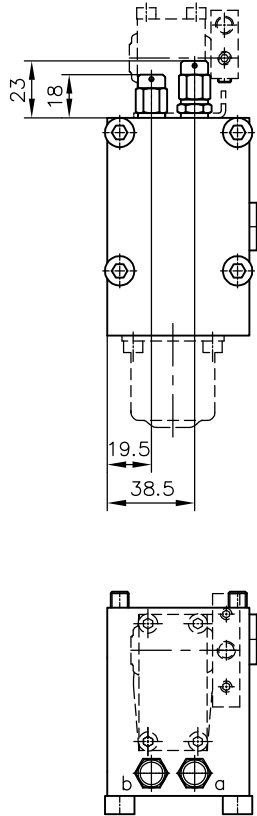

Type B..

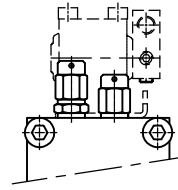

Type A..B..

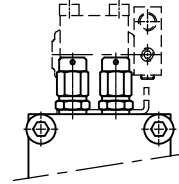

Type C..

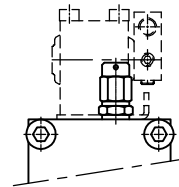

Type F 1 up to A..B.. F 3  
 FP 1 up to A..B.. FP 3  
 FPH 1 up to A..B.. FPH 3

Type S 1 up to A..B..S 1

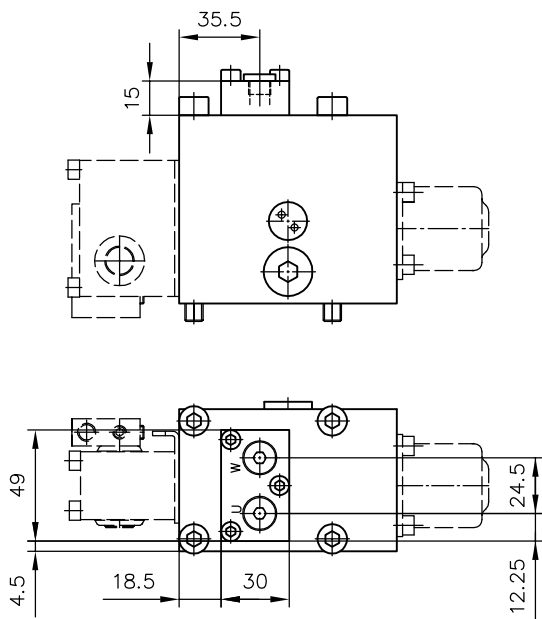

Pushbutton  
 (manual emergency actuation)  
 with type FPH..

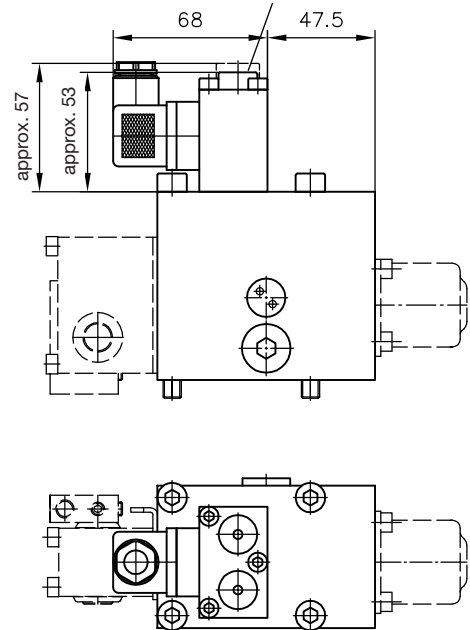

Ports conf. ISO 228/1 (BSPP):  
 W, U = G 1/8

**5.1.10 Sub-plate**

**For inlet section**

**Type /4  
/UNF 4**

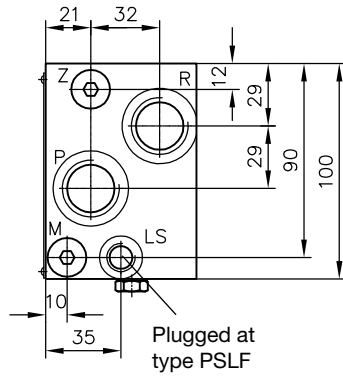

Tapped ports conf. ISO 228/1(BSPP) or SAE J 514

| Coding | Port<br>P, R     | M, LS, Z, T    |
|--------|------------------|----------------|
| /4     | G 3/4            | G 1/4          |
| /UNF 4 | 1 1/16-20 UNF-2B | 7/16-20 UNF-2B |

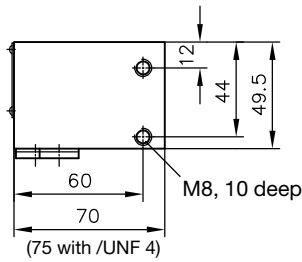

**For valve sections**

**Type /3.., /38, /4..  
/UNF 3..**

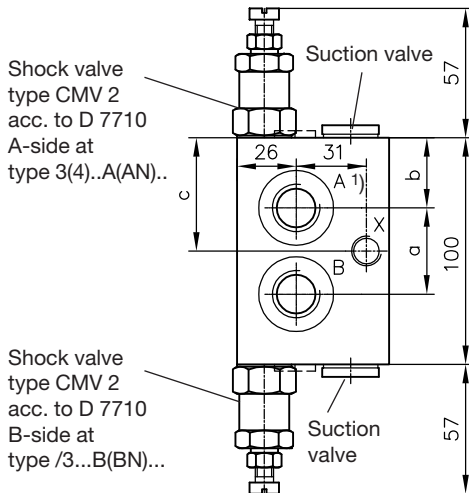

**Type /UNF 4 W**

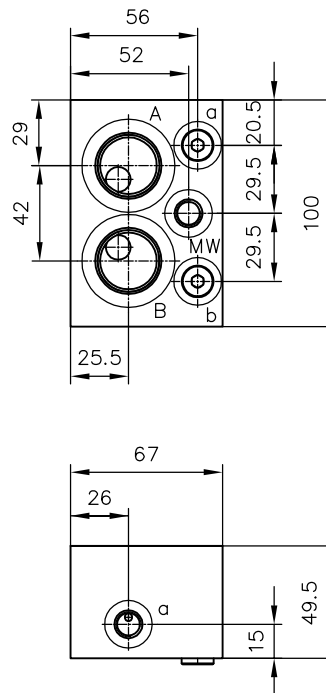

| Coding     | a  | b  | c  |
|------------|----|----|----|
| /3, /UNF 3 | 38 | 31 | 30 |
| /4, /UNF 4 | 42 | 29 | 30 |
| /UNF 3X    | 38 | 31 | 38 |

1) Port A is omitted with /38

Tapped ports conf. ISO 228/1 (BSPP) or SAE J 514

| Coding   | A, B             | W, U, X, MW, a, b |
|----------|------------------|-------------------|
| /3..     | G 1/2            | G 1/4             |
| /4..     | G 3/4            |                   |
| /UNF 3.. | 7/8-14 UNF-2B    | 7/16-20 UNF-2B    |
| /UNF 4.. | 1 1/16-12 UNF-2B |                   |

**End plates of the valve bank**

**Type E 1, E 2, E 4, E 5**

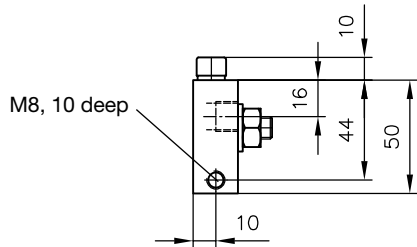
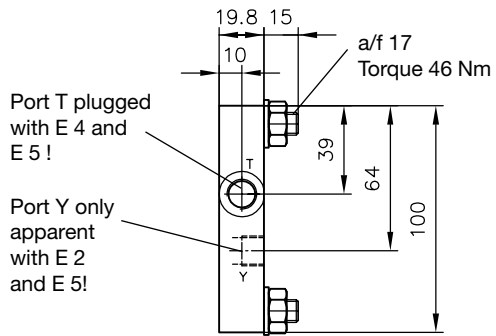

**Type E 3, E 6**

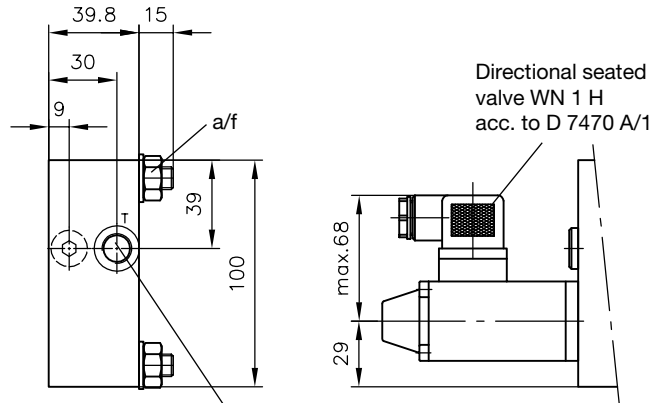

Port T plugged with E 6

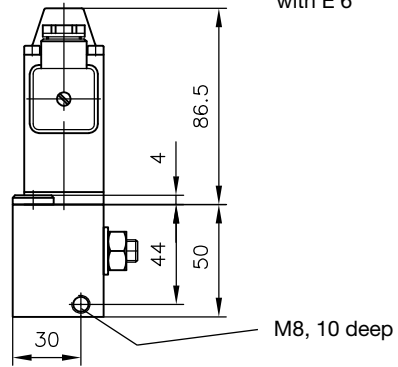

**Type E 7, E 8, E 9, E 10**

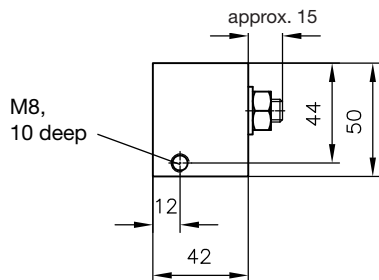
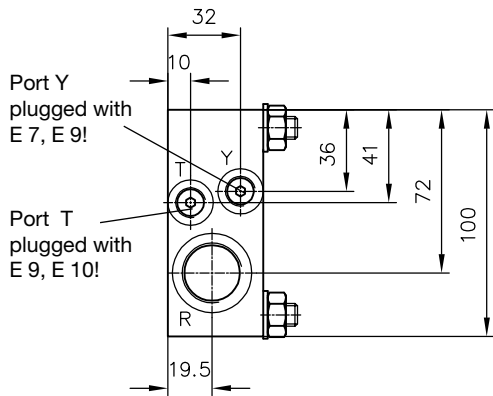

Ports conf. ISO 228/1 (BSPP):  
R = G 3/4  
T and Y = G 1/4

**5.2 Size 5**

**5.2.1 Hole pattern of the sub-plate**

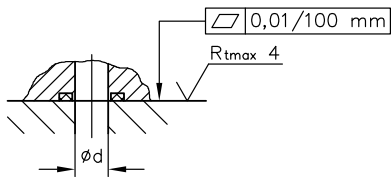
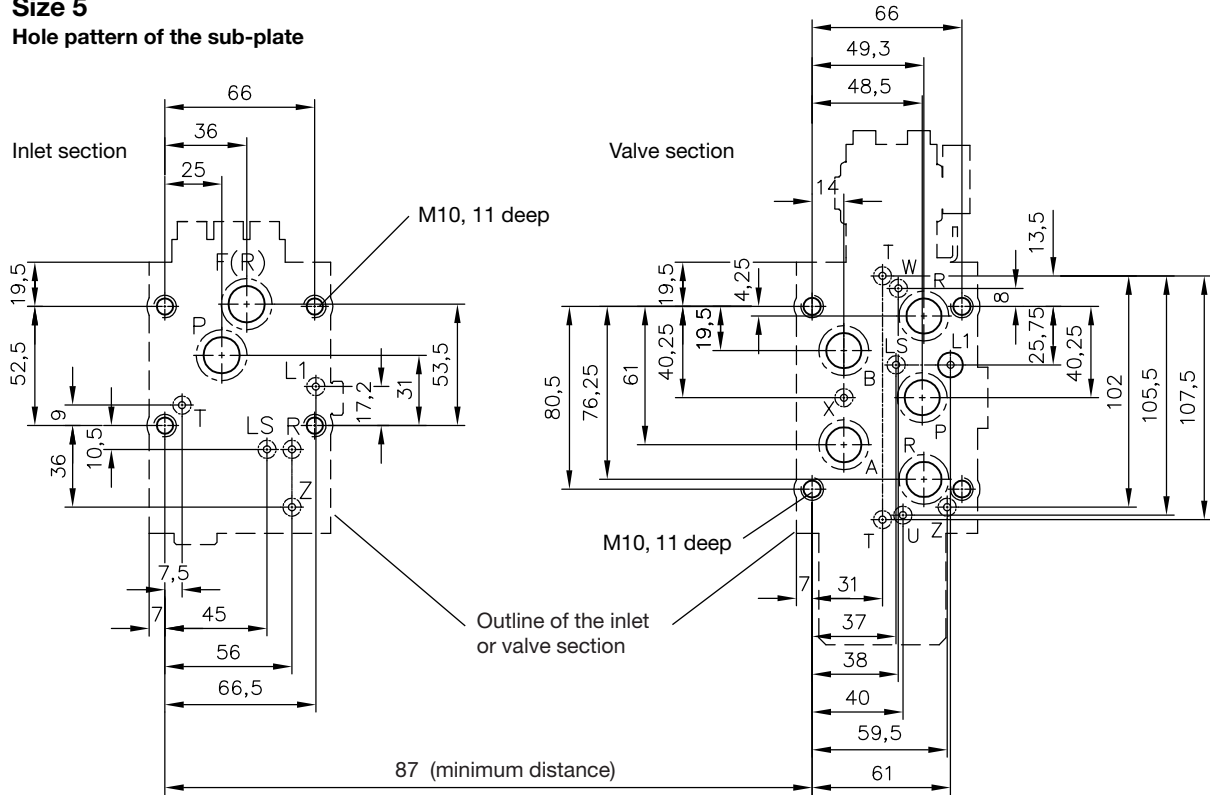

Inlet section:

| Ports           | $\phi d$ | O-ring 1)<br>PUR 90 Sh |
|-----------------|----------|------------------------|
| P, F(R)         | 16       | 17.12x2.62             |
| R, L1, LS, T, Z | 3.2      | 4.47x1.78              |

Valve section:

| Ports             | $\phi d$ | O-ring 1)<br>PUR 90 Sh |
|-------------------|----------|------------------------|
| P, R              | 15.5     | 17.12x2.62             |
| LS, T, U, W, X, Z | 3.2      | 4.47x1.78              |
| L1                | 3.2      | 7.65x1.78              |

1) These O-rings are also available as complete seal kits, see also sect. 6.3.5  
 Inlet section: DS 7700-F 52      Valve section: DS 7700-F 51

**5.2.2 Inlet section**

**Type PSLF(V) A...-5 and PSVF A...-5**

Pressure limiting valve  
 (not valid for type  
 PSVF A...-5)

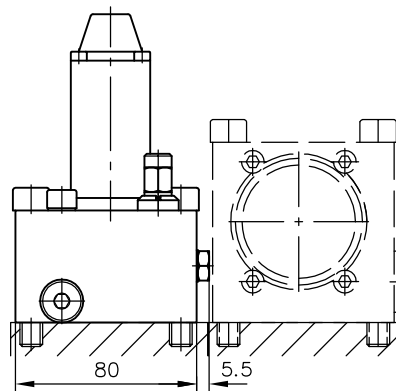
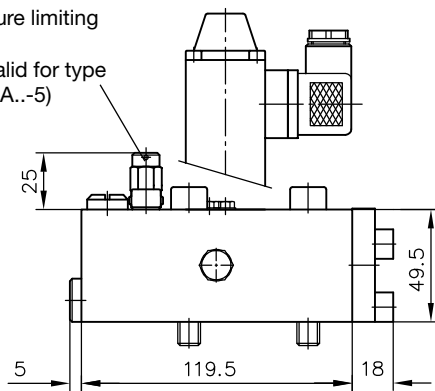

Socket head screw  
 ISO 4762 M10x60-8.8-A2K  
 Max. torque 40 Nm

Valve section  
 acc. to sect. 5.2

Type PSL..F(D)/...  
PSV..F(D)  
PSV..F(D)/...

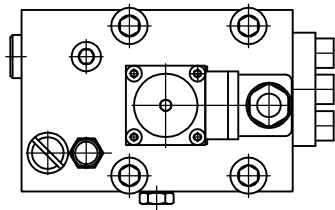
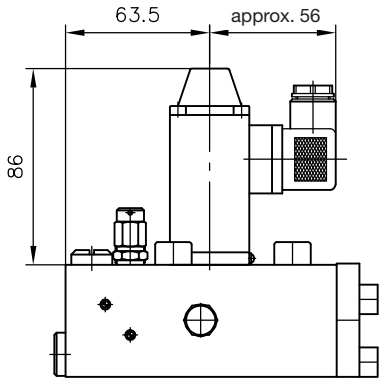

Type PSL..F(D).../...  
PSV..F(D).../...

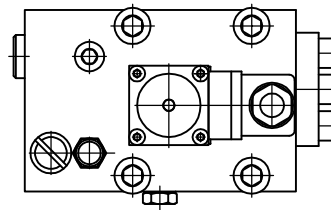
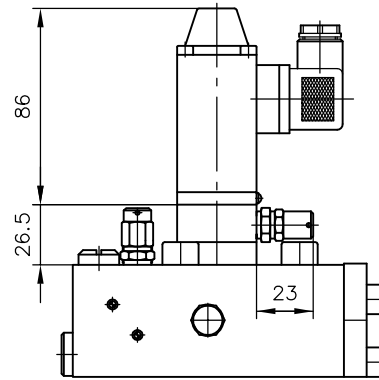

Type PSV...X...

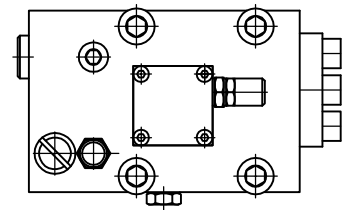
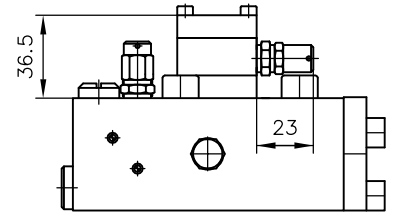

Type PSL..PA(PB, PD)/...  
PSV..PA(PB, PD)

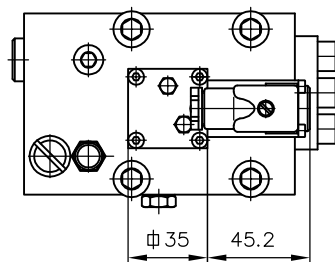
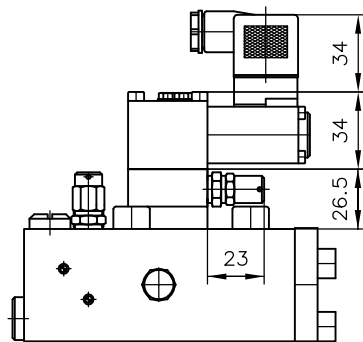

Type PSL..Z(V).../...  
PSV..Z(V).../...

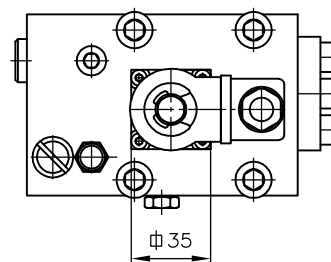
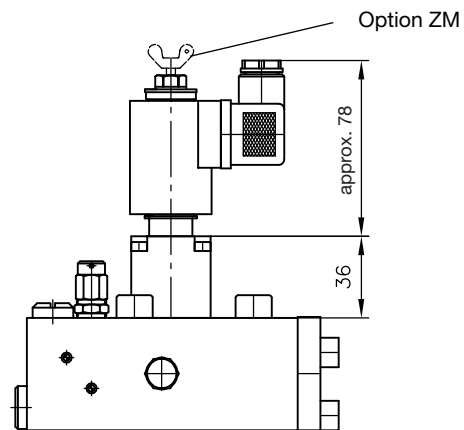

**5.2.3 Individual valve with manual actuation type A, C**

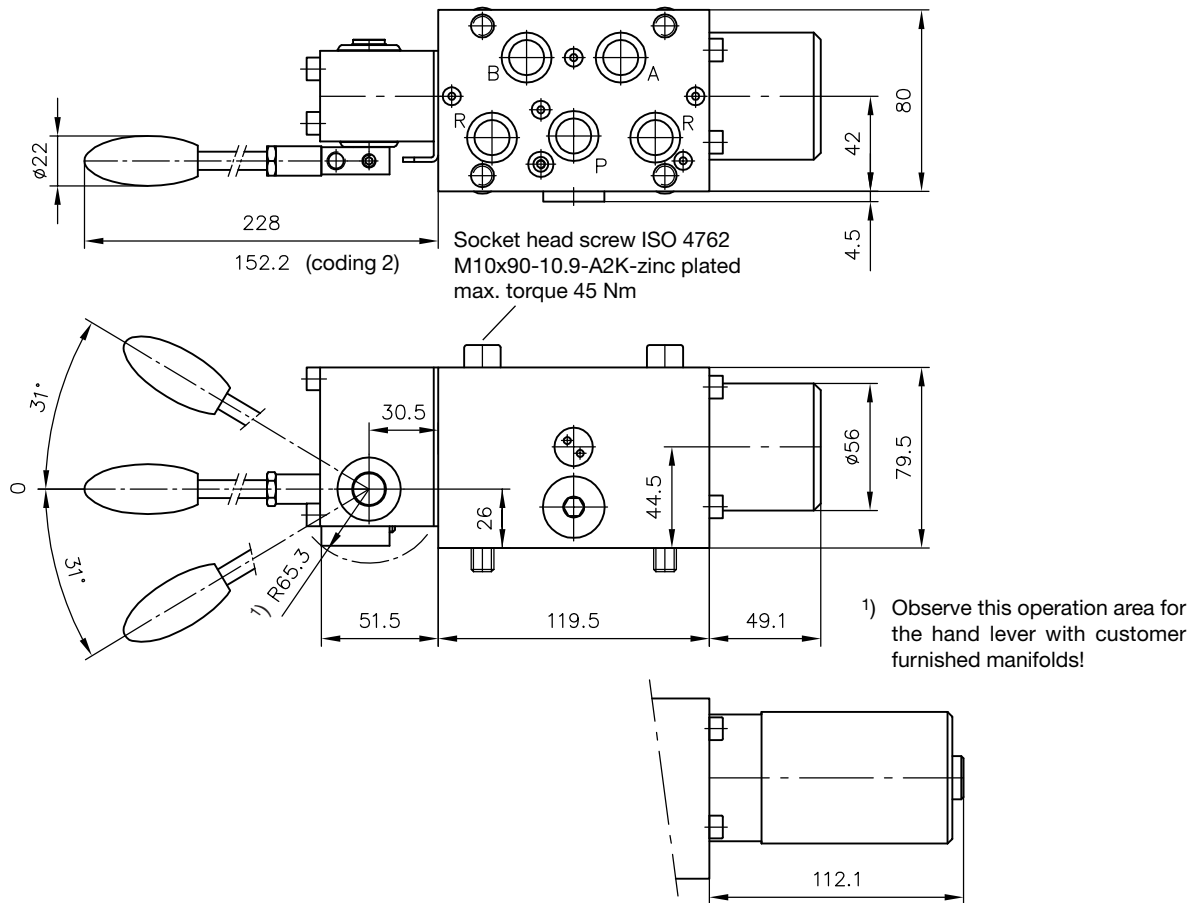

**5.2.4 Individual valves with actuation type EA, E0A**

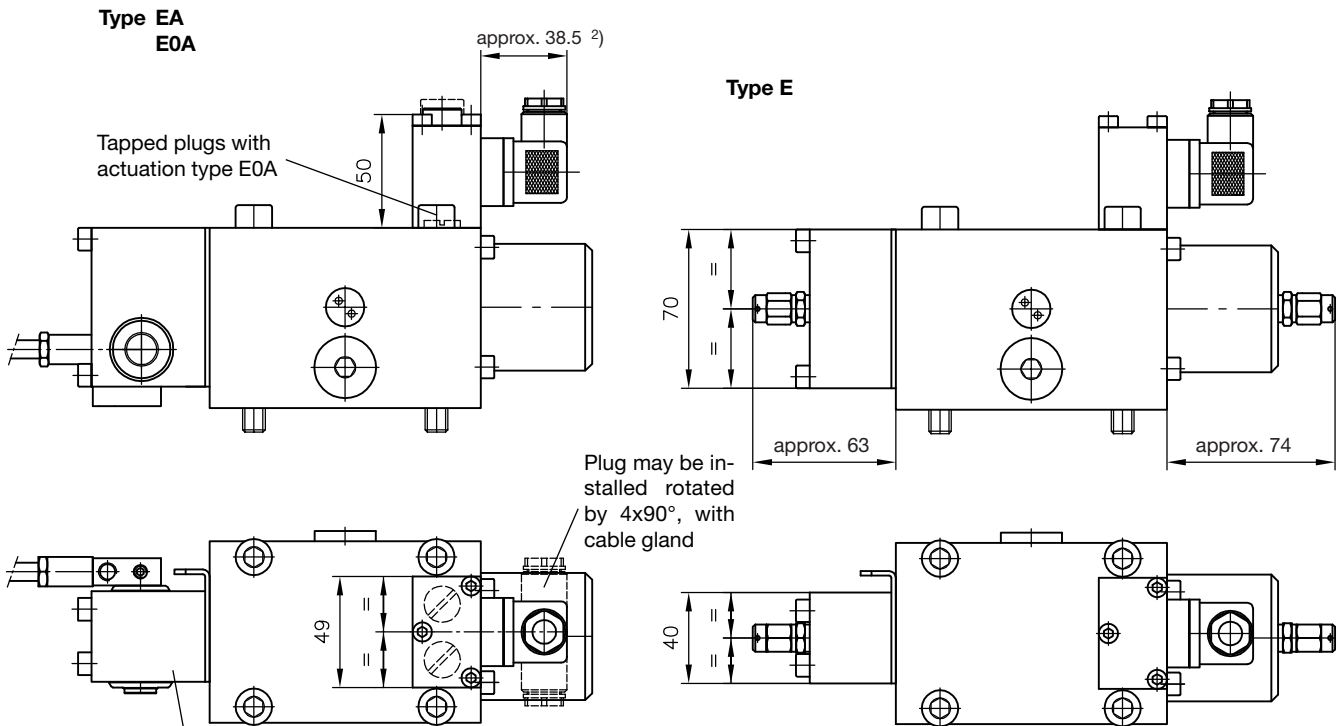

Lever housing at EA and HA (FA) can be angled at 180° in the same manner as described at sect. 6.3.4

<sup>2)</sup> This dimension depends on the manufacturer and can be up to 50 mm depending on the max. permissible size according to EN 175 301-803 A

Additional versions

Actuation type **EB, EAB**

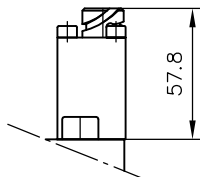

Actuation type **EBT, EABT**

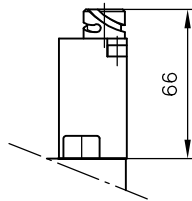

Actuation type **E(EA)...-AMP H 4**

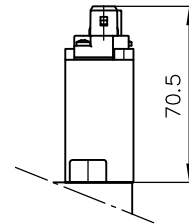

Actuation type **ET, EAT, ETH, EATH**

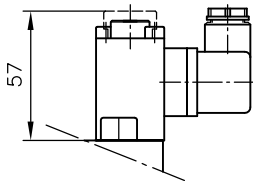

Actuation type **E(EA)...-G(X) 24 C 4**

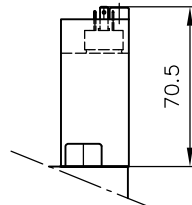

Actuation type **E(EA)...-G 24 EX**

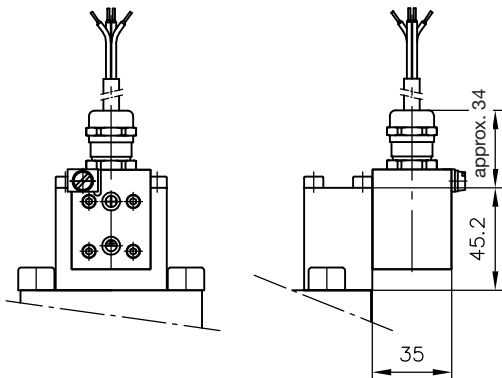

Actuation type **E(EA) - G 12 IS  
- G 24 MSHA**

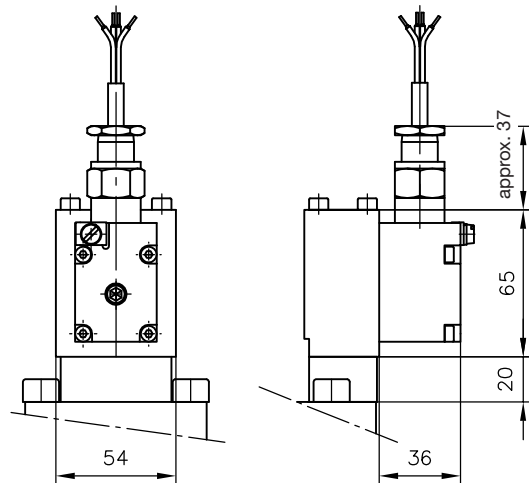

Actuation type **EB, EAB E(EA)...-G 24 EX 70**

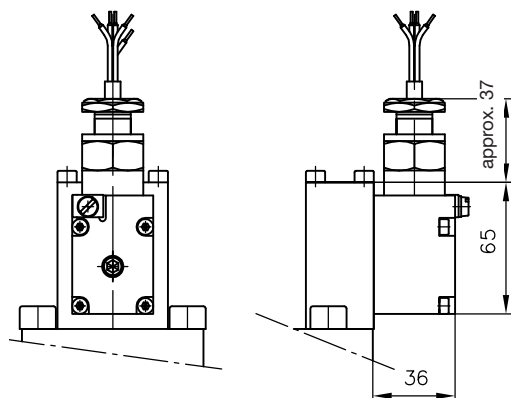

5.2.5 Individual valves with hydraulic actuation type F or HA, FA, HEA, FEA and H

Type HA, FA

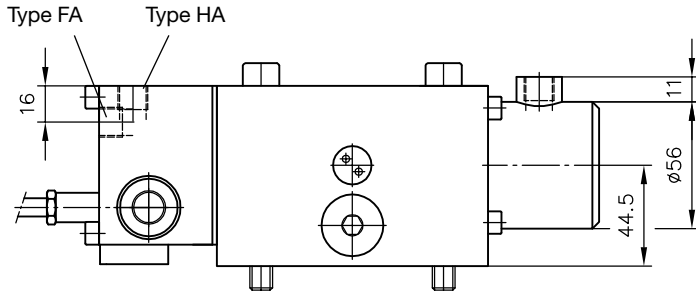

Type HEA, FEA

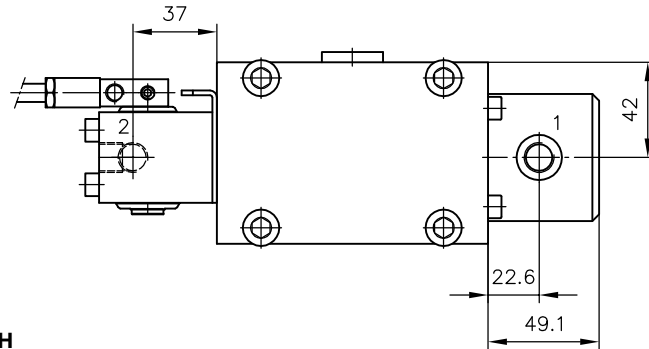
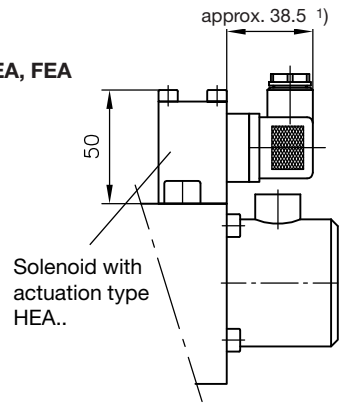

Type H

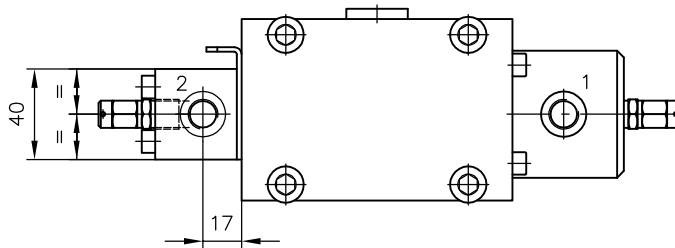
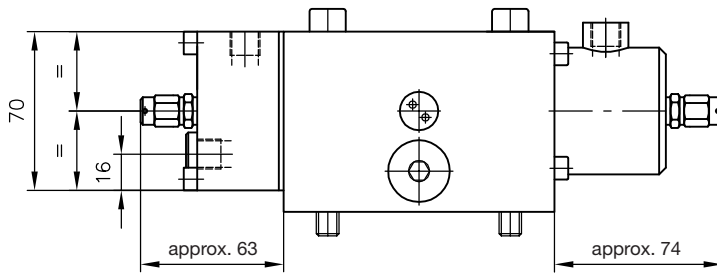

Ports conf. ISO 228/1 (BSPP) or (SAE-4, SAE J 514):  
1 and 2 = G 1/4 or 7/16-20 UNF-2B

1) This dimension (plug) depends on the make and may be up to 50 mm acc. EN 175 301-803 A  
Plug may be installed rotated by 4x90°, with cable gland

5.2.6 Individual valves with pneumatic actuation type PA and P

Type PA

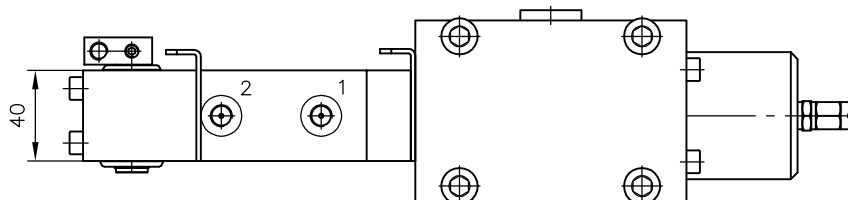
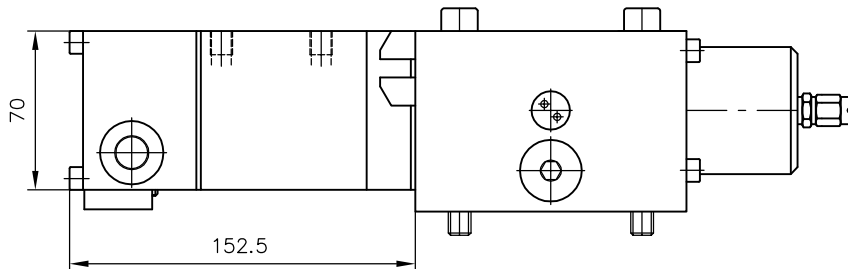

Ports conf. ISO 228/1 (BSPP):  
1 and 2 = G 1/8

**Type P**

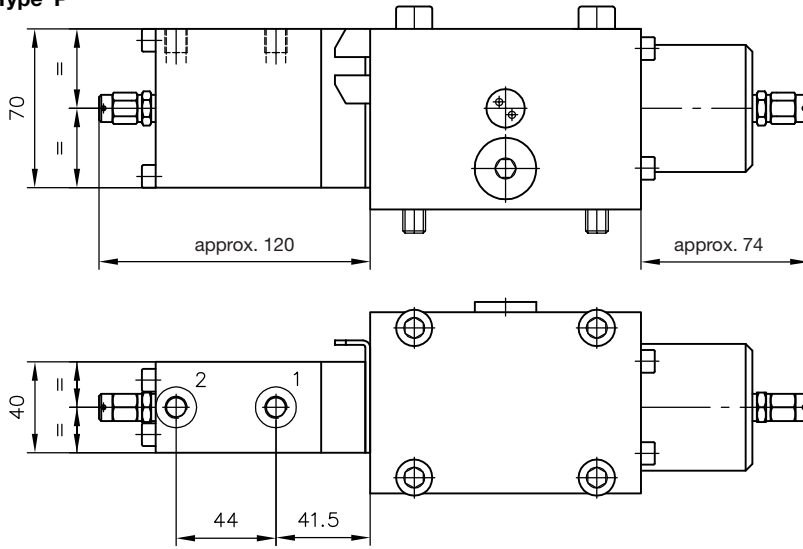

**5.2.7 Blanking plate type AX**

Mounting screw  
4 x socket head  
screw ISO 4762  
M10x35 - 8.8-A2K,  
40 Nm

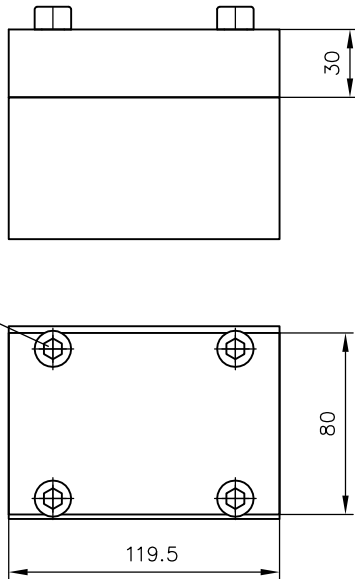

**5.2.8 Lift monitoring**

**Type WA, WA-EX n**

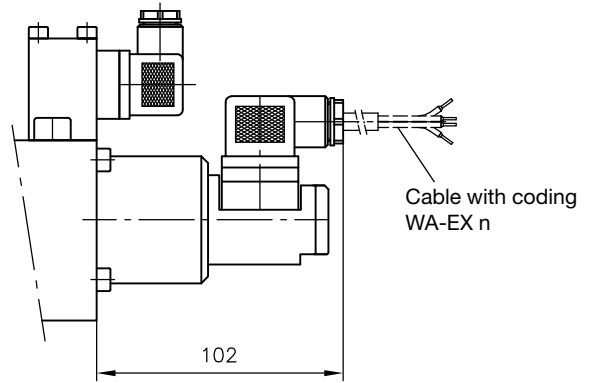

**5.2.9 Valve sections with secondary pressure limitation, functional cut-off and prop. pressure limitation**

**Type A..**

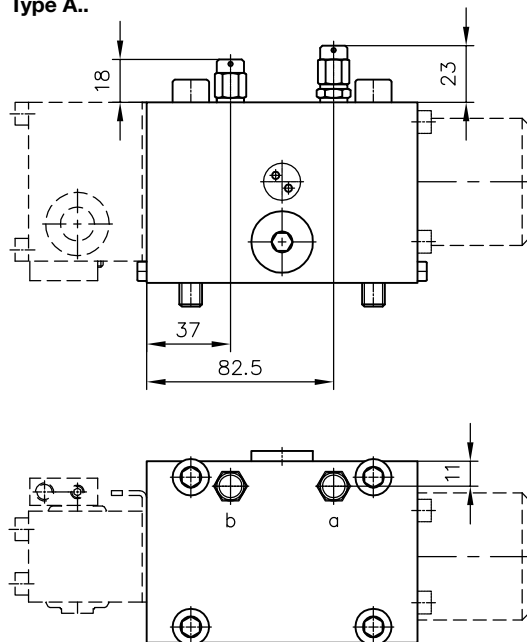

**Type B..**

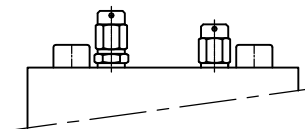

**Type A..B..**

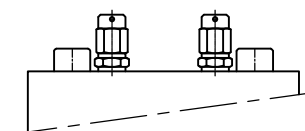

**Type C..**

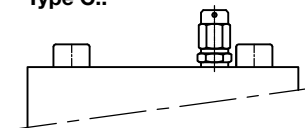

**Type S 1 up to A..B..S 1**

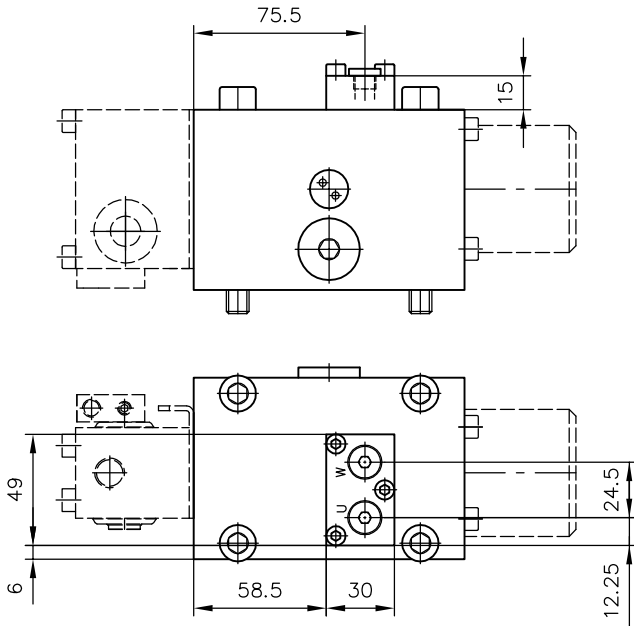

**Type F 1 up to A..B.. F 3**  
**FP 1 up to A..B.. FP 3**  
**FPH 1 up to A..B.. FPH 3**

Pushbutton  
 (manual emergency actuation)  
 with type FPH..

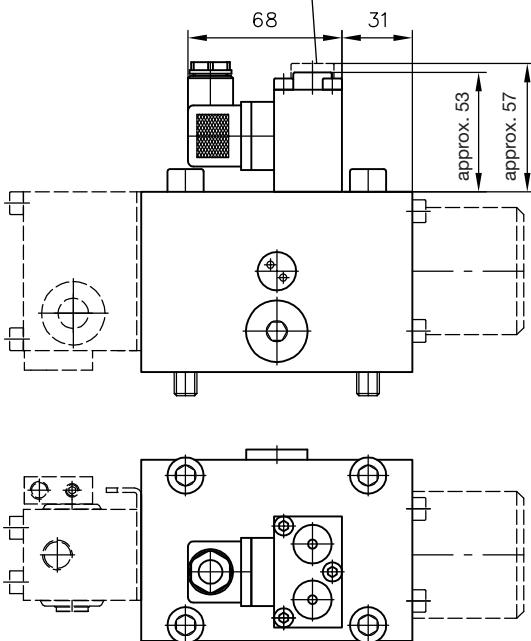

Ports conf. ISO 228/1 (BSPP):  
 W, U = G 1/8

**5.2.10 Sub-plate**  
**Type /Z AN... BN...**

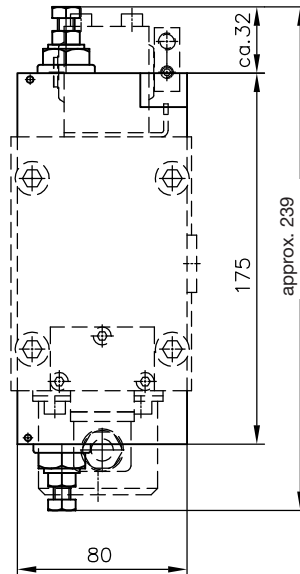
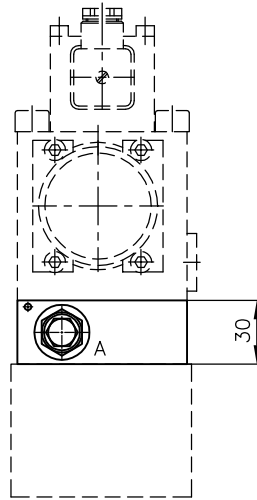

**5.2.11 Sub-plate**

For inlet section

Type /6

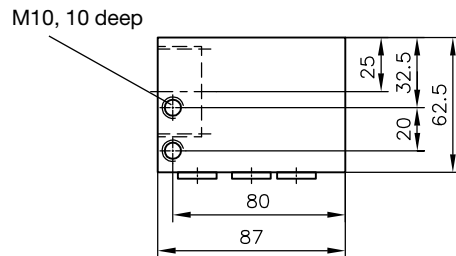
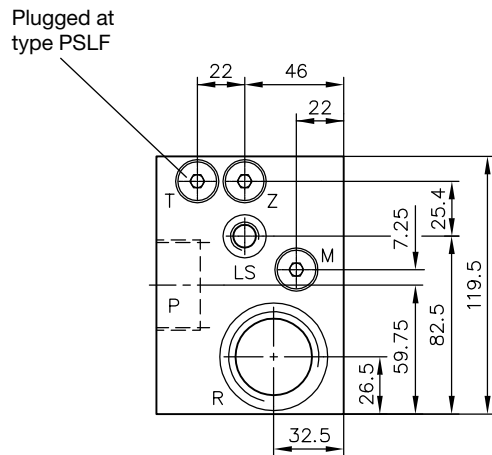

Type /7 SAE

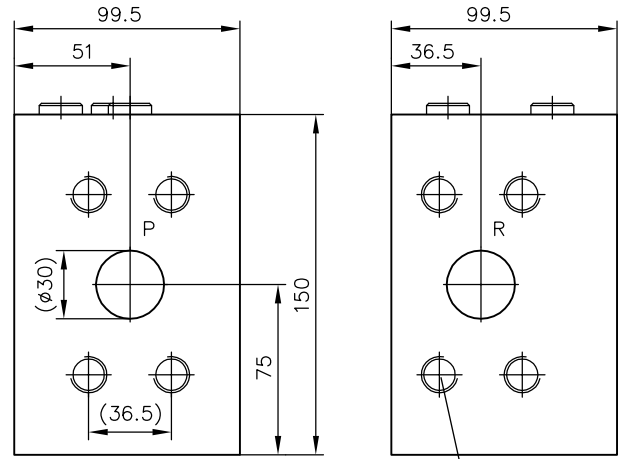

M16, 20 deep

M10, 11 deep

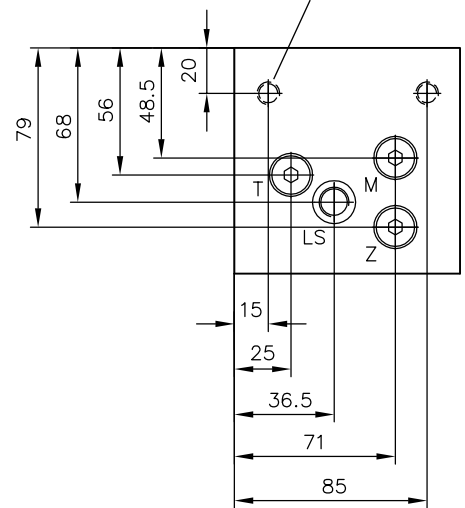

Ports conf. ISO 228/ BSPP) or SAE J 514

| Coding | Ports                 |             |
|--------|-----------------------|-------------|
|        | P and R               | M, LS, Z, T |
| /6     | G 1 1/4               | G 1/4       |
| /7 SAE | SAE 1 1/2" (6000 psi) | G 1/4       |

**For valve sections**

**Type /5, /58 <sup>1)</sup>, /53  
/5 S  
/5 X**

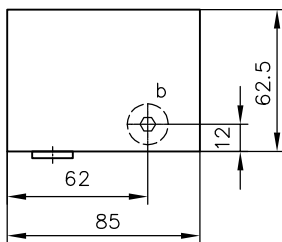
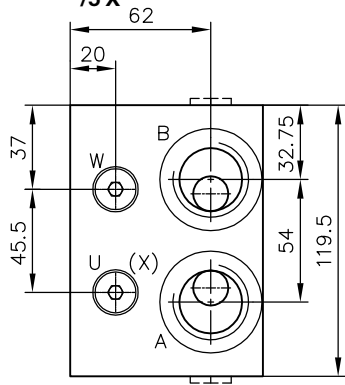

**Type /533, /534**

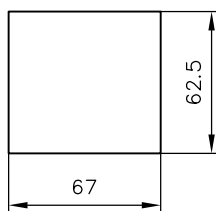
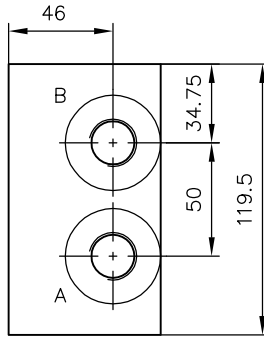

1) Port A is omitted with /58

Ports conf. ISO 228/1 (BSPP) or SAE J 514  
Coding

| Coding            | Ports                 |         |
|-------------------|-----------------------|---------|
|                   | A, B                  | W, U, X |
| /5, /5S, /58, 5 X | G 1                   | G 1/4   |
| /53               | G 1/2                 | ---     |
| /533              | G 1/2                 | ---     |
| /534              | G 3/4                 | ---     |
| /5 SAE, /5 SAE S  | SAE 1" (6000 psi)     | G 1/4   |
| /6 D SAE          | SAE 1 1/4" (6000 psi) |         |

**Type /5 SAE  
/5 SAE S, /5 SAE 8 <sup>1)</sup>**

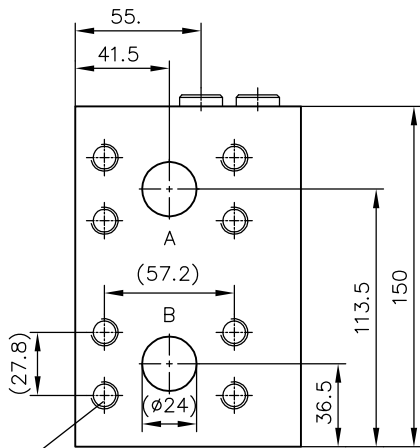

M12, 15 deep

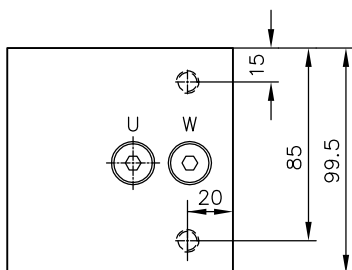

**Type /6 D SAE**

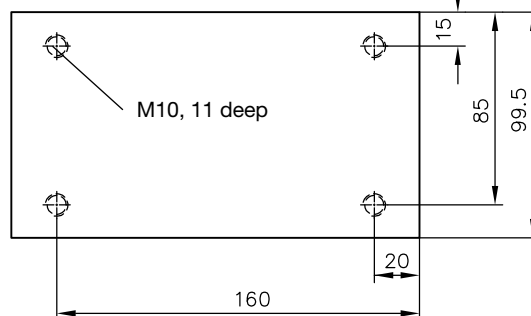
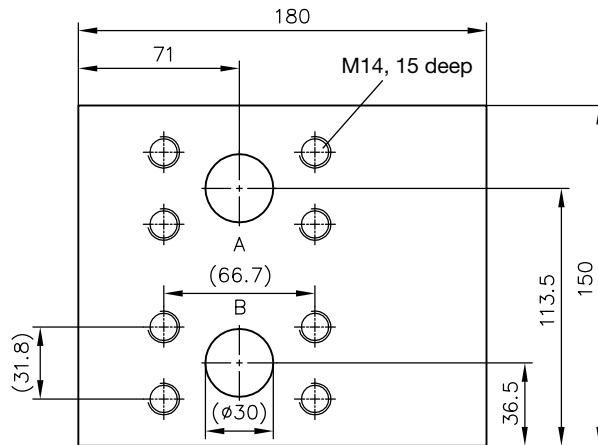

**End plates of the valve bank**

**Type E 1, E 2, E 4, E 5**

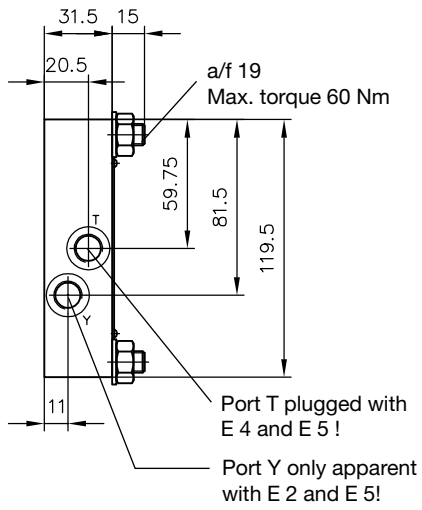

Type E 1 SAE  
E 2 SAE  
E 4 SAE  
E 5 SAE

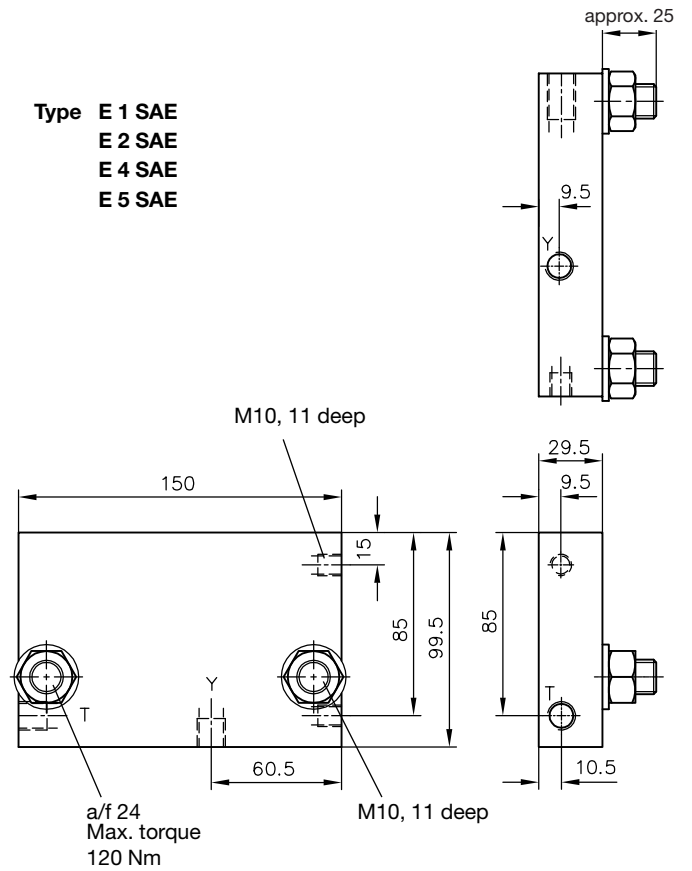

**Type E 3, E 6**

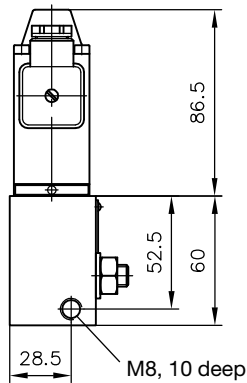
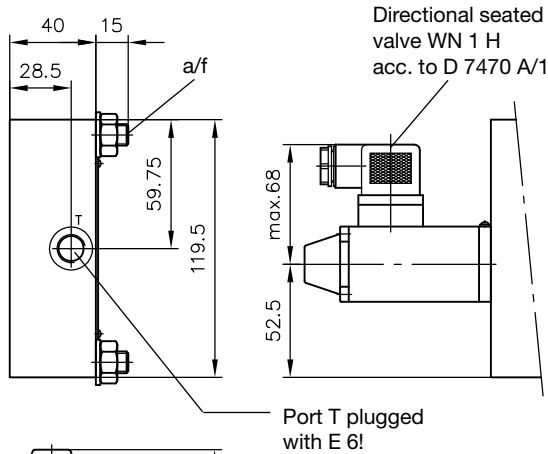

Ports conf. ISO 228/1 (BSPP):  
T and Y = G 1/4

Port Y plugged with E 1 SAE  
Port T plugged with E 5 SAE  
Port T and Y plugged with E 2 SAE and E 4 SAE

5.2.12 Adapter plate

Type ZPL 53  
ZPL 5 SAE 3

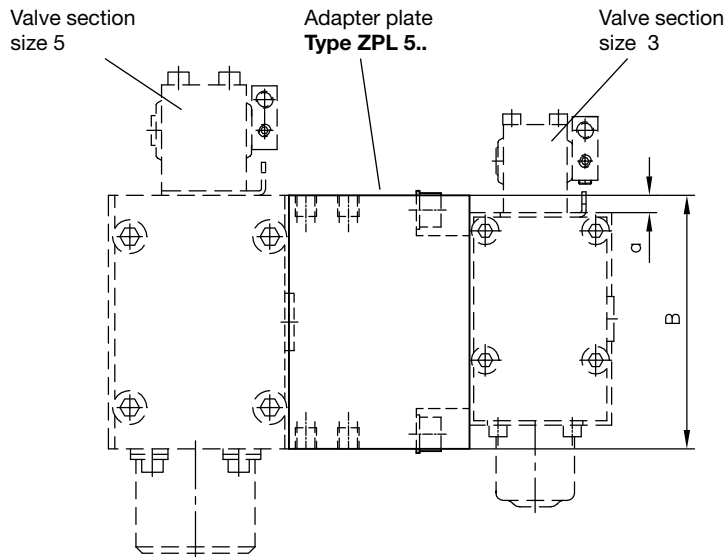
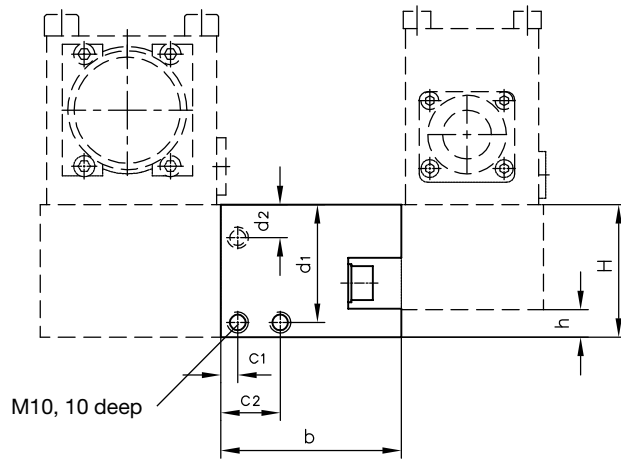

|             | B     | H    | a    | b    | c <sub>1</sub> | c <sub>2</sub> | d <sub>1</sub> | d <sub>2</sub> | h  |
|-------------|-------|------|------|------|----------------|----------------|----------------|----------------|----|
| ZPL 53      | 119.5 | 62.5 | 8.25 | 85   | 8              | 28             | 55.5           | --             | 13 |
| ZPL 5 SAE 3 | 150   | 99.5 | 25   | 62.7 | 18             | --             | 85             | 15             | 50 |

## 6. Appendix

### 6.1 Notes for selection and lay-out

#### a) To the connection block

There are, apart from the standard versions acc. to sect. 3.1.1 and 3.1.2. additional damping variations for the LS-signal type PSVF (coding S or B) duct listed in tables 2 or 4. These are required, if strong (load-) oscillations are externally induced on the control circuit. A general rule concerning the use of one or other variation can however not given.

#### To coding G

This version lacks the sequence valve at the damping element which is apparent at the standard version to enable quick depressurization down to the pre-load pressure during idle position of the valve spool. This results in a stronger damping effect than with the standard version, as all fluid from the spring cavity of the 3-way flow controller must pass the thread type throttle. Main application is with consumers prone to low-frequency oscillations - drawback is the delayed depressurization down to the pre-load pressure during idle position of the valve spool (pro-longed run-down).

#### To coding H

If on account of the required consumer velocity at least one spool valve with reference number 5 (raised circulation pressure) is utilized, then, in order to maintain the necessary pressure difference between 2- and 3-way flow controller, the circulation pressure of the 3-way flow controller must be raised to approx. 14 bar. This means, of course, greater power dissipation.

#### To coding Z, ZM, V and PA, PB, PD (see table 8)

When using these valves for an emergency stop function, it has to be taken into account that there will be a certain min. residual pressure during pushing load while a valve spool is elevated!

| Dampening screw<br>acc. to table 2 and 5<br>Coding | Residual pressure at load induced<br>pressure of |         |
|--|--|---------|
|  | 250 bar  | 350 bar |
| S, G, W, B   | 125  | 150     |
| B 4  | 60   | 70      |
| B 5  | 75   | 80      |
| B 6  | 85   | 95      |
| B 7  | 100  | 120     |

Viscosity  $\leq 60 \text{ mm}^2/\text{s}$

#### b) To the spool valve sections

##### To coding 1 (example SLF 5-A1 L 120/63...)

On the one hand, there is a higher consumer flow with directional spool valves without an inflow controller (code number 1) in comparison with one having a 2-way flow controller (code No 2, 4, 5), as the flow is then directly dependent on the control pressure of either the connection block's 3-way flow controller (approx. 10 bar) in type PSLF, or the metering valve of a variable displacement pump (approx. 14 to 20 bar), in type PSVF. On the other hand, the load-independence is lost, if several consumers are actuated simultaneously, because the consumer with the highest load pressure rules the pressure level of the LS-signal given to the 3-way flow controller and so defines the available oil flow in the system.

When another valve with lower pressure is actuated now, the flow can only be regulated by throttling, which means if the highest load pressure varies, the spool elevation (= throttling) of the second consumer has to be reset to maintain a constant delivery flow to the consumer. This consumer flow can be calculated approx. by ( $Q_{A;B}$  = expected consumer flow,  $Q_{nom}$  = rated consumer flow for a valve with inflow controller code number 2,  $\Delta p_{controller}$  = pressure difference at the flow controller of the connection block or pump).  $Q_{A;B} \approx Q_{nom} \cdot \sqrt{0,2 \cdot \Delta p_{controller}}$

##### To coding 2 (example SLF 5-A2 0 63/80)

The standard version of the spool valve comes with load compensation. Due to the control pressure of the inflow controller (approx. 6 bar), it regulates a constant flow related only to the spool elevation, making its delivery independent of other consumers or system pressure  $Q \approx \sqrt{\Delta p_{controller}} \cdot A_{valve \text{ spool}}$

##### To coding 5 (example SLF 5-A 5 J 160/160)

This version has an increased control pressure enabling higher consumer flows (see also above code No 1 and 2). The pressure of the flow controller is 10 bar resulting in a 1.3 higher flow compared to the standard version (code No 2).

##### To coding 7 (example SLF 5-A 7 H 160/160)

Like coding 5, due to the necessary pressure drop only in combination variable displacement pump / constant pressure system i.e. basically type PSVF.

##### To coding 26 und 56 (example SL 3-326 J 40/25...)

Symptoms of resonance (audible knocking of the 2-way flow controllers) can be sometimes caused if pulsating consumers e.g. radial or axial piston motors with a low number of pistons) are connected.

This is prevented by use of a restrictor check valve combination which delays the closing of the inflow controller. This doesn't harm the characteristic of the functional cut-off or the pressure limiting valves.

##### To coding R 2, R 5 and R 7

The flow controller acts additionally like a check valve. Thus preventing a reversal of the flow direction in case of starving pump delivery.

**c) Flow-pattern variations**

**Flow pattern symbol J, B, R, O and I, Y, Z, V**

Oscillations may occur depending on application during start (e.g. winches) or during normal operation (e.g. crane booms). They can be caused by the natural frequency of the hydraulic motors or external load variations e.g. swinging load. The flow coding (table 15) of the respective spool should correspond to the cylinder ratio as far as possible.

| Symbols    | Description   | Application  |
|------------|---|--|
| J, B, R, O | Creation of a back pressure of approx. 20 bar at 1/3 spool lift and more. | When combined with over-center valves e.g. for boom controls                               |
| I, Y, Z, V | Creation of a back pressure of approx. 100 bar for up to 1/3 spool lift   | Hydraulic motors (because of pressure rise due to area ratio 1:1), e.g. with cabin slewing |

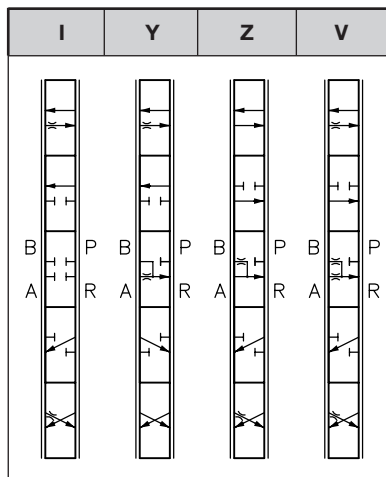
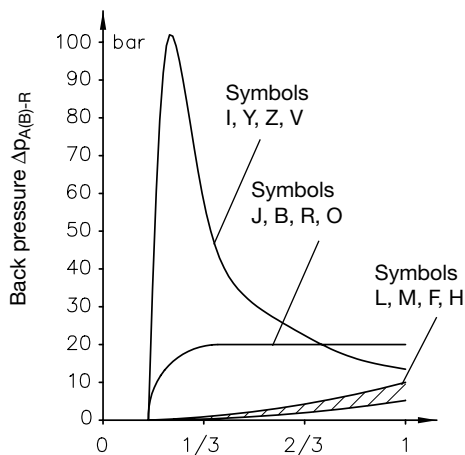

Available versions:

|              |                |                  |
|--------------|----------------|------------------|
| SL 3 - I 6/6 | SL 3 - Y 45/45 | SL 5 - I 25/25   |
| I 10/10      | Y 60/60        | I 120/120        |
| I 16/16      |                | I 140/140        |
| I 25/25      | SL 3 - Z 25/25 | I 160/160        |
| I 30/30      | Z 45/45        |                  |
| I 40/40      | Z 60/60        | SL 5 - Y 150/150 |
| I 63/63      |                |                  |
| I 80/80      |                | SL 5 - Z 80/80   |
|              |                |                  |
| SL 3 - V 6/6 | SL 5 - V 25/25 |                  |
| V 10/10      | V 120/120      |                  |
| V 16/16      | V 140/140      |                  |
| V 25/25      |                |                  |
| V 40/40      |                |                  |
| V 63/63      |                |                  |
| V 80/80      |                |                  |

**Flow pattern symbol W**

This 4/2-way directional spool valve is intended for applications where a constant velocity is required e.g. blower or generator drives. The ability of prop. speed control is restricted, but load independency is ensured via the inflow controller (table 13).

**Flow pattern symbol X**

This 2/2-way directional spool valve is intended for hydraulic motors (e.g. fan drives) and features maximum speed in idle position. The speed can be reduced proportionally down to dead-halt by energizing the side "b". The load-independence is provided when combined with an inflow controller (table 13).

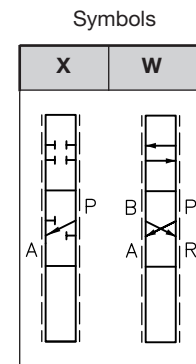

Available versions:

|                         |                      |       |
|-------------------------|----------------------|-------|
| SL 3-W 50/50            |                      |       |
| SL 5-W 120/120          |                      |       |
| Coding acc. to table 13 | $Q_{max A, B}$ (lpm) |       |
|                         | 2                    | 120   |
|                         | (1)                  | (150) |
| 5                       | 67                   | 150   |
| SL 3-X 80               |                      |       |
| Coding acc. to table 13 | $Q_{max A, B}$ (lpm) |       |
|                         | 2                    | 80    |
|                         | (1)                  | (107) |
| 5                       |                      | 107   |

**Flow pattern symbol P, A, T, Q, K (only size 3)**

These spools show positive overlap. Type P overlaps in both switching directions, i.e. during elevation of the spool the connection  $P \rightarrow A(B)$  is opened before of connection  $B(A) \rightarrow R$ .

This results in an undesired pressure intensification at cylinders (area ration  $\neq 1$ ), therefore we recommend type A, T, Q or K as these have a one-sided overlapping only. They are intended for consumers such as hydro-motors / double acting cylinders (area ratio 1:1) with righting moments / -forces, as well as at cylinders with drawing loads (area ratio  $\neq 1$ ). A short-term preloading prevents "lowering jolts" and "running empty". These valve spools can substitute load-holding valves to a limited extent. It should be taken into account, that a short-term working against the max. system pressure takes place.

The flow coding for A should be selected higher than for B with spool codings A and T to prevent unintended pressure intensifications (for spool codings Q and K  $Q_{nom A} < Q_{nom B}$ )

Symbols

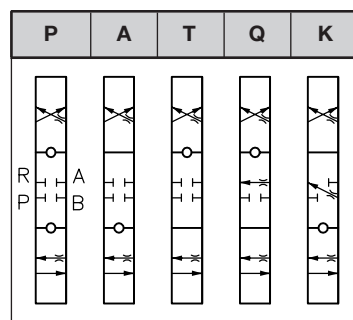

| Cylinder area ratio $A_{piston} / A_{rod}$ | Valve spool code letter |      | Example |
|--|-------------------------|------|---------|
|  | Piston side             |      |         |
| = 1  |                         | P..  | P 40/40 |
| $\neq 1$                                   | connection A            | A, T | T 25/16 |
|  | connection B            | Q, K | Q 40/63 |

**Flow pattern symbol G**

3/3-way directional spool valve for single acting cylinders

Restrictions:

- there is no load signal triggered via the LS-line
- i.e. it is not suited for solenoid actuated constant delivery pump systems (type PSLF)
- The flow while lowering is only throttled (no flow control functionality) and therefore load-dependent. It is therefore necessary (safety!) to limit the drop rate by a drop rate braking valve e.g. type SB acc. to D 6920

Available version:

SL 3 - G 80/40

SL 5 - G 160/160

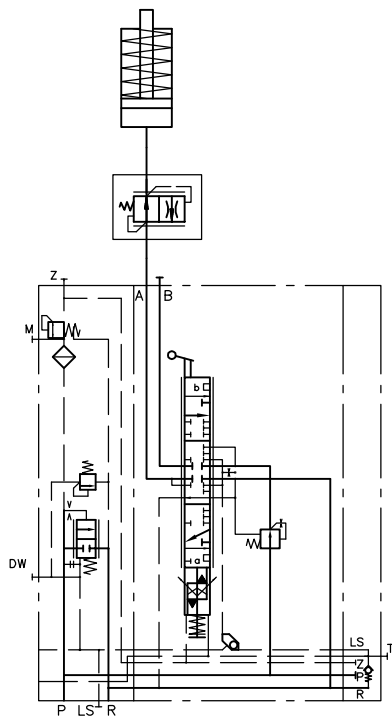
**d) Variations for special operation conditions or -requirements****Operation at potentially explosive areas**

electro-hydraulic actuation (type E or EA) version G 24 EX..., see sect. 3.1.4 table 10 and sect. 4.3

**Monitoring of the spool elevation (safety- / switching function)**

with contact- or proximity switch for monitoring the idle position of the valve spool (suffix to the types A, C, EA, HA, HEA, PA acc. to sect. 3.2.1 tables 20 and 21 and sect. 4.3)

**Maritime ambient climate**

The aggressive sea atmosphere requires sufficient corrosion protection of all moving part of the actuations with hand lever. The actuation shaft in the hand lever housing is therefore made of stainless steel as standard. All other parts are either corrosion inhibiting gas nitrided or made of stainless steel.

Exception: Housing of pneumatic actuation P or PA which is made of anodized light alloy.

**Pressure surges in the return line**

Minor leakage may appear at the spring domes of actuations type AS, CS, E, EAS and E0AS when excessive pressure peaks (>150 bar) do occur in the return line. This can be prevented by use of enforcement flanges (suffix **G** acc. to table 21 in sect. 3.2.1) (suffix **G** acc. to table 21 in sect. 3.2.1)

**Note:** The perm. pressure in the return line is limited to approx. 50 bar (see sect. 4.1). The functionality of the actuation solenoids could be harmed in case of excessive pressure.

**e) Use of variable displacement pumps**

With Load-sensing controls in alliance with variable displacement pumps, the LS-signal duct for the pump pressure-flow controller (Load-Sensing metering valve) is relieved, to minimize circulation losses during idle position (no consumer flow). This limiting takes place via the proportional spool valves. Without this decompression the pump would have to work during no-lift position with all the remaining flow against the pressure set at the safety valve of the pressure regulator.

As there exist spool valves without this limiting possibility, some brands of pressure-flow controllers have an internal bypass orifice or throttle between LS-signal entrance and decompressed leakage outlet.

In case of the prop. spool valves type PSVF this is not necessary and can even cause malfunctions due to lost control oil. The control oil flow is for functional reasons consciously limited (approx. 2 lpm) (slow-motion of the consumer).

**Note:** Care must therefore be taken, to ensure that a possible bypass orifice in the pressure-flow regulator is plugged!

**f) Combination with load-holding valves**

It can happen due to exterior variations of load and resonance that the control system starts to oscillate, if three regulation devices, the 3-way flow controller in the pump or the connection block, the 2-way flow controller at the spool valve section plus load holding insert are connected in series. This can be effectively suppressed by systematic use of a bypass orifice and throttle-, check-, pre-load valve combination within the control oil circuit at the load-holding valve type LHDV acc. to D 7770. A similar behavior can be achieved with use of the over-center valves type LHT acc. to D 7918.

**g) Combination of more than 12 spool valves**

Through the consecutive connection of the LS-signal duct, a total of max. 12 spool valves can be linked. Whether the spool valves are arranged in one or more valve banks is irrelevant. This restriction results from the only limited available oil flow (ensuring slow-motion movements). If more than 12 spool valves in separated directional spool valve banks are to be coupled via the LS-signal, a chaining via external shuttle valves is to be used.

**i) Indications of actuation HEA**

The following notes to the connection of the valve bank have to be observed to ensure a flawless function of the electric and hydraulic actuation.

**Combination with hydraulic control devices similar to type FB, KFB acc. to D 6600 (circuitry acc. to example 1)**

**Examples 1**

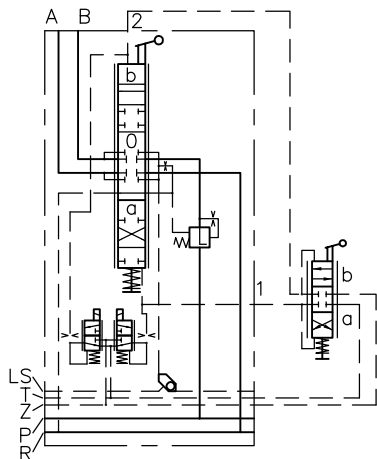

**Combination with common hydraulic joy-sticks or hydraulic control devices type FB and KFB acc. to D 6600 (circuitry acc. to example 2)**

The pressure reducing valves integrated in the joy-sticks open the consumer line to the tank during idle position. The control oil flow would escape via this bypass when a valve is simultaneously solenoid actuated. Therefore it is a must to provide check valves for the control lines at this kind of circuitry. The same applies to hydraulic actuations. The used throttles however limit the bypass leakage. The control oil supply must be dimensioned so that this leakage can be compensated (> 0.7 lpm per actuated valve section plus the internal leakage of the hydraulic joy-stick).

**Examples 2**

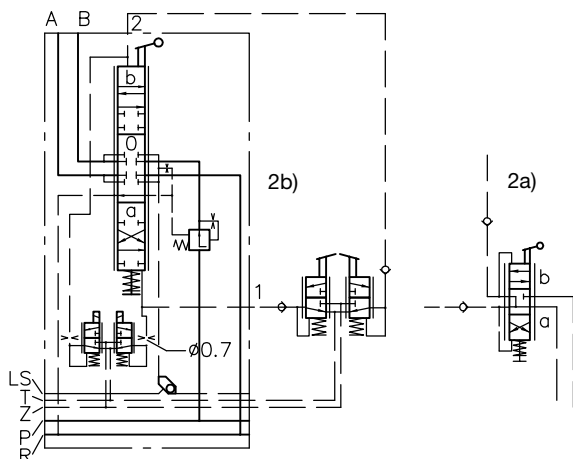

**j) Optional components**

**For electro-hydraulic actuations**

1. Plugs MSD 3-309 standard, belongs to the scope of delivery  
SVS 296107 Plug with LED's for functional cut-off acc. to sect. 3.2 table 17 (for more details, see D 7163)
2. Electric amplifier EV 22 K2-12(24) acc. to D 7817/1 One board can control two directional valves.
3. Electric amplifier EV 1 M2 - 12/24 or EV 1 M2 - 24/48 acc. to D 7831/1 A remote control potentiometer with direction switches is required additionally (see detailed information in D 7831/1 sect. 5.2).
4. Logic valve control type PLVC acc. to D 7845 ++
5. Joystick type EJ 1, EJ 2 and EJ 3 acc. to D 7844
6. Radio controls are accepted, if they fulfill the requirements of SK 7814. (Approved brands:  
Co. HBC-Elektronik in D-74564 Crailsheim,  
Co. HETRONIK Steuer-Systeme in D-84085 Langquaid,  
Co. NBB-Nachrichtentechnik in D-75248 Ölbronn-Dürrn,  
Co. SCANRECO Industrieelektronik AB, Box 19144, S-5227 Södertälje)

**Load-holding valves**

Load-holding valves type LHT acc. to D 7918 or type LHDV acc. to D 7770 and note sect. 6.1 f, type LHK acc. to D 7100 only with "very stiff" systems and directional spool valves without inflow controller (coding 1 acc. to table 15, sect. 3.2.1)

**Other valves**

- Proportional spool valve type PSL(V) size 2 acc. to D 7700-2 (can be combined via intermediate plate ZPL 32 with size 3)
- Proportional spool valve type PSL(V) size 3 acc. to D 7700-3 (can be combined via intermediate plate ZPL 32 with size 2 or via intermediate plate ZPL 53 with size 5)
- Proportional spool valve type PSL(V) size 5 acc. to D 7700-5 (can be combined via intermediate plate ZPL 53 with size 3 and via intermediate plate ZPL 52 with size 2)
- Proportional pressure reducing valve type PMZ acc. to D 7625

## 6.2 Example circuit

Control system with PSVF, and variable displacement pump

Flow pattern symbol  
acc. to the order  
example

**PSVF A1/380/4 - 3 - A2 J 40/40 A200 B200/E /3 AN210 BN210**  
**- A2 J 80/40 A280 B130/E /3 AN290 BN140**  
**- A2 J 25/16 /EA /3**  
**- E1 - G 24**

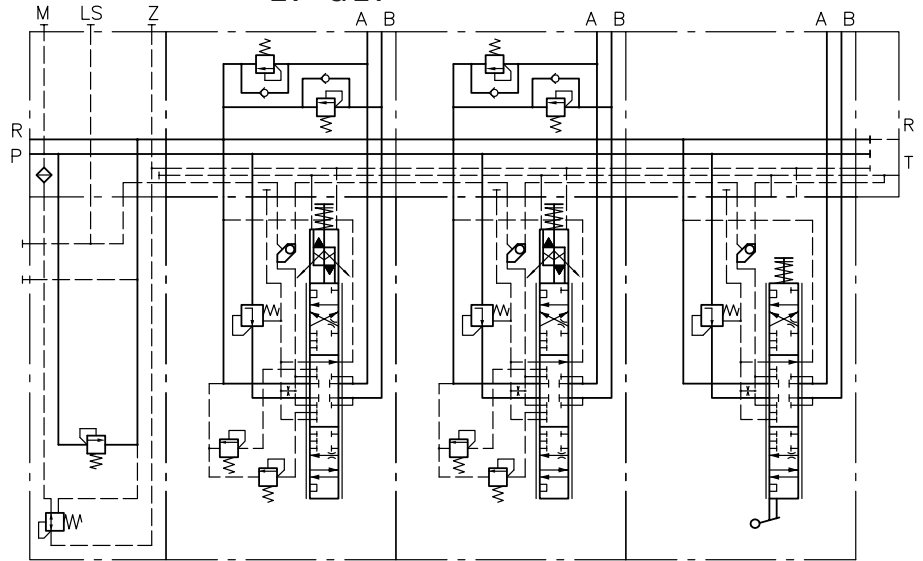

## 6.3 Notes regarding assembly, installation and conversion

All installation, set-up, maintenance and repairs must be performed by authorized and trained staff.  
 The use of this product beyond the specified performance limits, use of non specified fluids and/or use of not genuine spares will cause the expiration of the guarantee.

### 6.3.1 Mounting

The mounting of the valve bank must be performed in such a way that no stress is induced.  
 Three screws and elastic washers between valve assembly and frame are recommended for fastening.

### 6.3.2 Piping

All fittings used must utilize deformable seal materials.  
 Do not exceed the specified torque!

### 6.3.3 Notes for converting the inlet section type PSL(V)F A../..-5

The inlet section type PSLF A../..-5 can be converted any time into a connection block for variable displacement pump systems (correct type now PSVF AS../..-5) and vice versa.  
 This requires replacing the parts listed below.

**Attention:** The screw (part No. 6380 013) ⑩ or carburetor jet M4x0.6 are secured with liquid screw lock, which must be applied again during reinstallation of these parts.  
 When converting type PSVF../..-5 into PSLF../..-5 an additional damping screw (part No. 7778 301) ⑪ is required.

### Type PSLF A../..-5

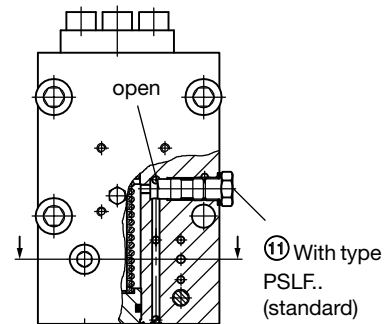
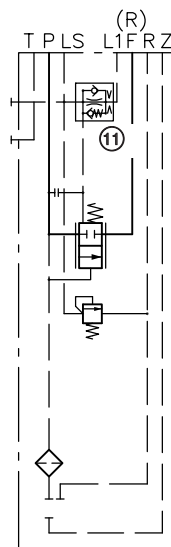

⑪ With type PSLF../.. (standard)

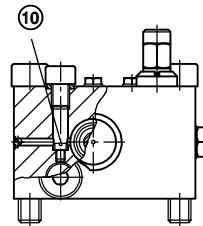

### Type PSVF A../..-5

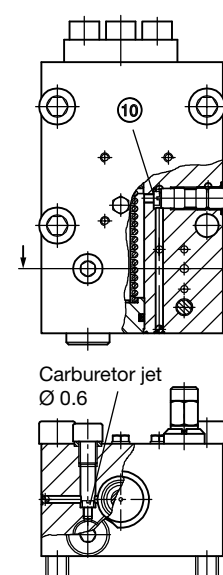
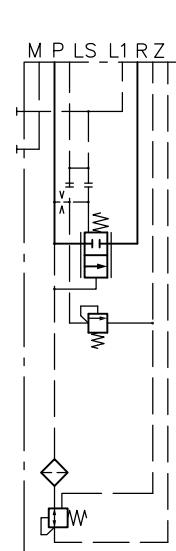

Carburetor jet  
Ø 0.6

- ⑩ With type PSVF AS../..-5
- Tapped plug (7778 036) with type PSVF A../..-5 (standard)
- Screw (7778 062) with type PSVF AB../..-5

### 6.3.4 Notes on changing the spool

The valve spools are not mated to one spool housing. The refore valve spools can be changed at any time to adapt to changing consumer consumption. The following routine is to be followed particularly:

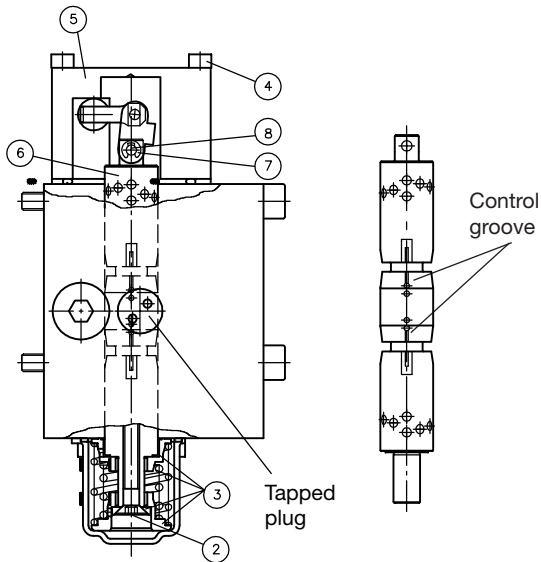
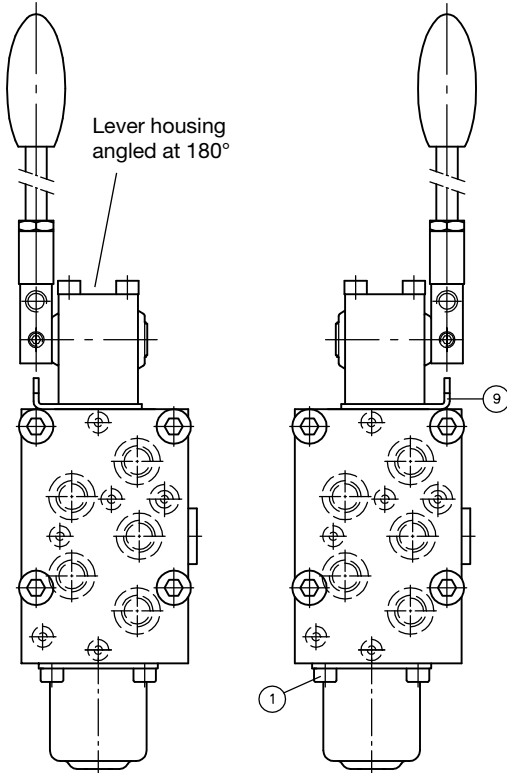

### Advice on changing the valve spool

1. Slacken screws ① (ISO 4762-M5x8-8.8-A2K), remove spring cover
2. Remove screw ② (M 6x40, machined flat head screw drawing No. 7709 042)
3. Remove spring assembly including spring cap ③
4. Slacken screws ④ (ISO 4762-M5x50-8.8-A2K)
5. Lift lever housing including spool out of spool housing, drawing ⑤ ⑥
6. Remove circlip DIN 6799 3,2 and remove bolt ⑦ ⑧
7. Assemble with (new) spool in reverse sequence

**Attention:** The control grooves of the valve spool should always be installed towards the end plate! Exception: Valve spools with flow coding 80 (size 3) and 160 (size 5) do not show control grooves.

### Indications for angling the lever housing by 180° (inversion of the shifting mode)

As set out in 1. - 7. above, however instead of a new valve spool the existing one has to be disconnected, angled at 180° and remounted (see above mentioned note). The intermediate plate ⑨ together with the lever housing, have to be angled at 180°. All lever housings of the valve bank have to be rotated!

### 6.3.5 Seal kits

|               | Size 3       | Size 5       |
|---------------|--------------|--------------|
| Inlet section | DS 7700-F 31 | DS 7700-F 51 |
| Valve section | DS 7700-F 32 | DS 7700-F 52 |
| Sub-plate     | DS 7700-F 34 | DS 7700-F 54 |