

# High Performance Linear Servomotor

4020, 5020



## ***Precision, powerful linear motion***

The brushless DC tubular linear motor's shaft contains rings of powerful rare earth magnets that interact with the stator coils to produce rapid, precise and powerful motion. The stator's length and diameter determine the force level, while the shaft length determines the stroke.

Linear motion is initiated by a motion controller, which relays detailed move profiles to the motor. A precision encoder reports motor position to the controller for closed loop control. The motor's position and force are fully programmable and there is no backlash or compressibility to compromise position accuracy.

Contact us to discuss your application requirements.

## TYPICAL APPLICATIONS

- Robotics and factory automation
- Processing equipment
- Packaging equipment
- Pumping / dispensing
- Material / product testing
- Machine tools
- Textile (tufting equipment)
- Paper converting
- Transfer equipment
- Automation welding

## FEATURES

- Single moving part – integral bearings
- Compact size
- Brushless direct drive technology
- Fully programmable
- Clean, quiet operation
- 1180 lb peak force
- >180 in / sec
- 40 G acceleration
- Strokes up to 20 inches
- Clean, quiet operation
- Long life / low maintenance

## ADVANTAGES

- Increased throughput, a function of its high acceleration
- Exceptional accuracy
- Consistent repeatability
- Environmentally friendly – no hydraulic fluids
- Exceptionally high force per volume
- High force / weight ratio
- Quiet
- Lifecycle cost savings of up to 50 percent over existing motion control systems because of:
  - Reduced wear and friction – meaning lower repair and maintenance costs because it has just one moving part and integral bearings
  - High operating efficiency
  - Low cost of operations / power consumption

**MOOG**  
COMPONENTS GROUP

# Linear Motors

## WHAT IS A TUBULAR LINEAR SERVOMOTOR?

The Moog linear motor is essentially a conventional brushless motor with an unconventional twist.

The design of Moog's core patent began with the magnetic design of a rotary brushless motor. Engineers cut the rotor lengthwise, laid it out flat, and then curled the assembly into a tube from the other direction. The permanent magnets now formed a stack of rings in alternating magnetic polarity. Engineers suspended the magnetic shaft in a column of current-carrying coils held in slots along a metallic core – the stator.



The company's engineers then rebuilt the shaft using more powerful magnets to increase the force produced, and lengthened the motor to create a longer stroke.

The result of these design improvements is the Moog linear motor: a compact motor with all the advantages of existing technology and none of the disadvantages.

In short: a motor poised to replace a portion of today's pneumatic and ball screw, as well as some hydraulic motion control technology.

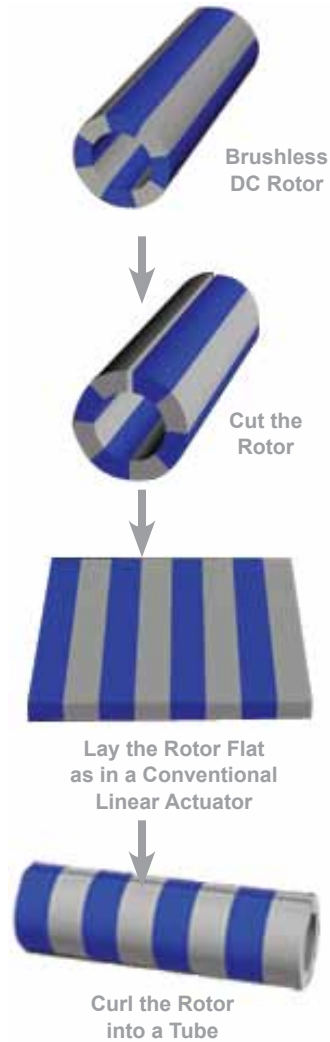

### The Result:

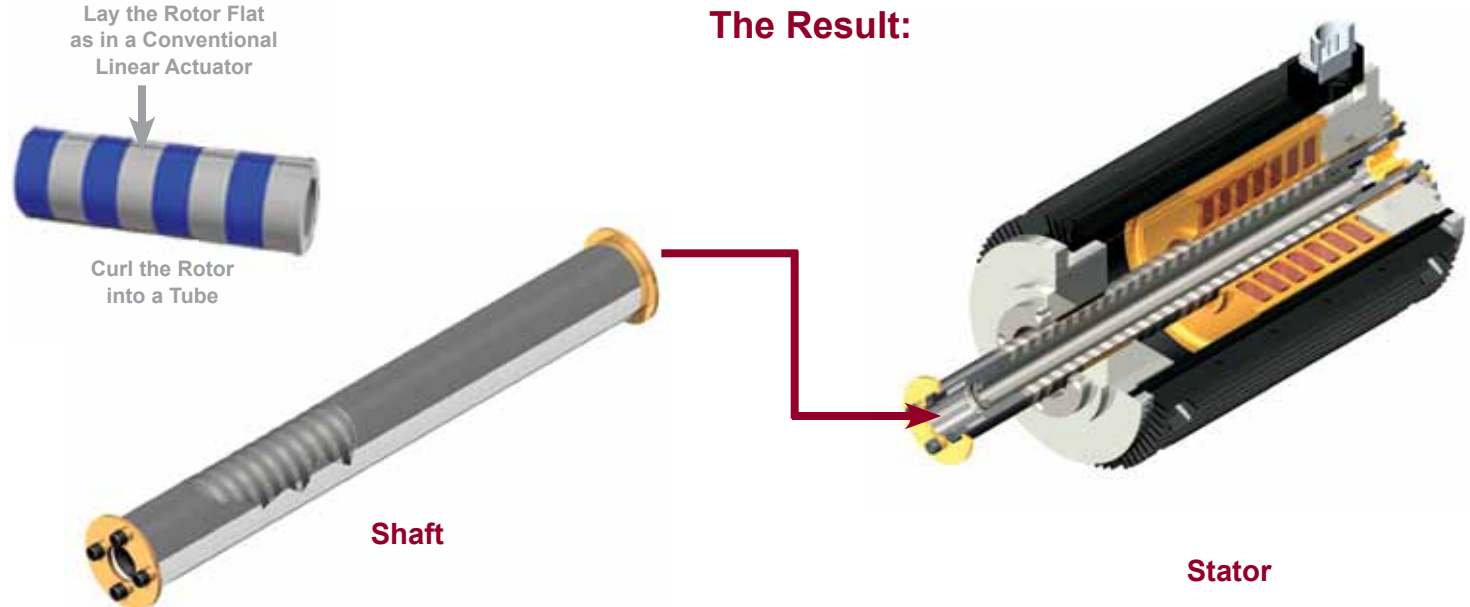

## PART NUMBERING SYSTEM GUIDE

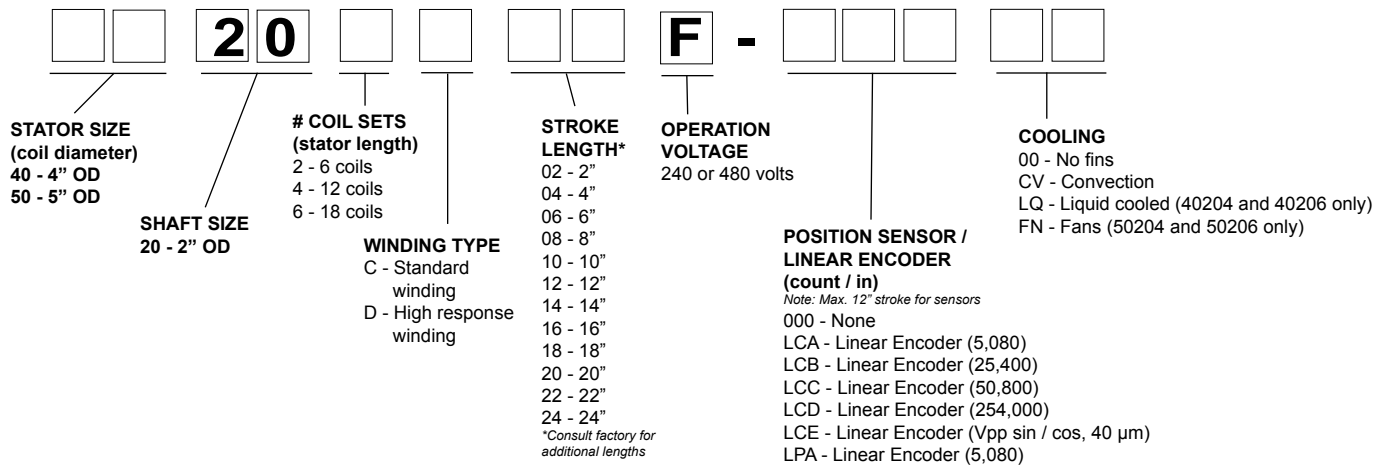

*Note: All motors contain temperature switches.  
Consult factory for controller and feedback devices available.*

## SPECIFICATIONS

Parameter	Units	4020						5020					
		2C	2D	4C	4D	6C	6D	2C	2D	4C	4D	6C	6D
Peak Force (1 sec)	lbf	410	410	850	850	1180	1180	360	360	780	780	1100	1100
	N	1824	1824	3781	3781	5249	5249	1601	1601	3469	3469	4893	4893
Peak Force (3 sec)	lbf	310	310	660	660	1020	1020	300	300	680	680	970	970
	N	1379	1379	2936	2936	4537	4537	1334	1334	3025	3025	4315	4315
Peak Current (1 sec)	A	45	90	45	90	45	90	50	100	50	100	50	100
Peak Current (3 sec)	A	25	50	25	50	25	50	30	60	30	60	30	60
Continuous Static Force (nat. convection)	lbf	80	80	170	170	260	260	160	160	320	320	450	450
	N	356	356	756	756	1156	1156	712	712	1423	1423	2002	2002
Continuous Static Force (forced air)	lbf	n/a	n/a	n/a	n/a	n/a	n/a	n/a	n/a	490	490	710	710
	N	n/a	n/a	n/a	n/a	n/a	n/a	n/a	n/a	2180	2180	3158	3158
Force Sensitivity (at 50% of 3 sec Peak Current)	lbf / A	13.7	6.8	27.7	13.8	44.1	22.0	11.7	5.8	26.9	13.4	38.7	19.3
	N / A	60.9	30.2	123.2	61.4	196.2	97.9	52.0	25.8	119.7	59.6	172.1	85.8
Back EMF Constant (ph-ph)	$V_{pk} / (\text{in} / \text{sec})$	2.09	1.05	4.08	2.04	6.44	3.22	1.94	0.97	4.04	2.02	6.04	3.02
	$V_{pk} / (\text{m} / \text{sec})$	82.3	41.3	160.6	80.3	253.5	126.8	76.4	38.2	159.1	79.5	237.8	118.9
DC Winding Resistance (ph-ph at 25° C)	ohms	2.9	0.7	5.9	1.5	8.8	2.2	1.6	0.4	3.2	0.8	4.8	1.2
Winding Inductance (ph-ph)	mH	20.5	5.1	40.3	10.1	60.5	15.1	19.6	4.9	39.2	9.8	58.1	14.5
Motor Constant	lbf / sqrt (watt)	9.2	9.2	13.2	13.2	17.1	17.1	10.6	10.6	17.3	17.3	20.4	20.4
	N / sqrt (watt)	40.9	40.9	58.7	58.7	76.1	76.1	47.1	47.1	77.0	77.0	90.7	90.7
Detent Force (peak)	lbf	10	10	10	10	10	10	10	10	10	10	10	10
	N	44	44	44	44	44	44	44	44	44	44	44	44
Thermal Resistance (nat. convection)	°C / W	0.28	0.28	0.19	0.19	0.13	0.13	0.23	0.23	0.13	0.13	0.09	0.09
Thermal Resistance (forced air)	°C / W	n/a	n/a	n/a	n/a	n/a	n/a	n/a	n/a	0.06	0.06	0.04	0.04
Maximum Stroke	inch	20	20	16	16	12	12	20	20	16	16	12	12
	m	0.508	0.508	0.406	0.406	0.304	0.304	0.508	0.508	0.406	0.406	0.304	0.304
Weight (add 0.62 lbm for each inch of stroke) (add 0.11 kg for each centimeter stroke)	lbm	31	31	44	44	58	58	41	41	58	58	81	81
	kg	14.1	14.1	20.0	20.0	26.3	26.3	18.6	18.6	26.3	26.3	36.7	36.7

# Linear Motors

## DIMENSIONS

### Model 4020

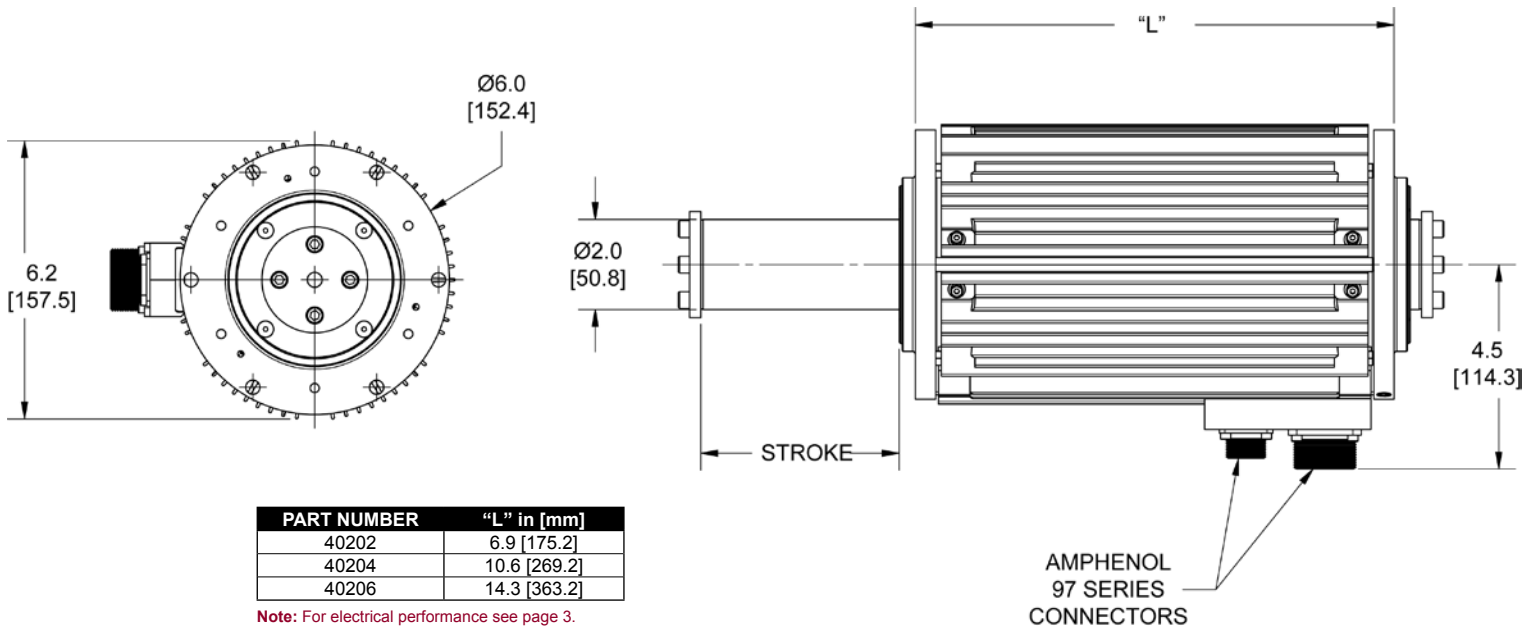

### Model 5020

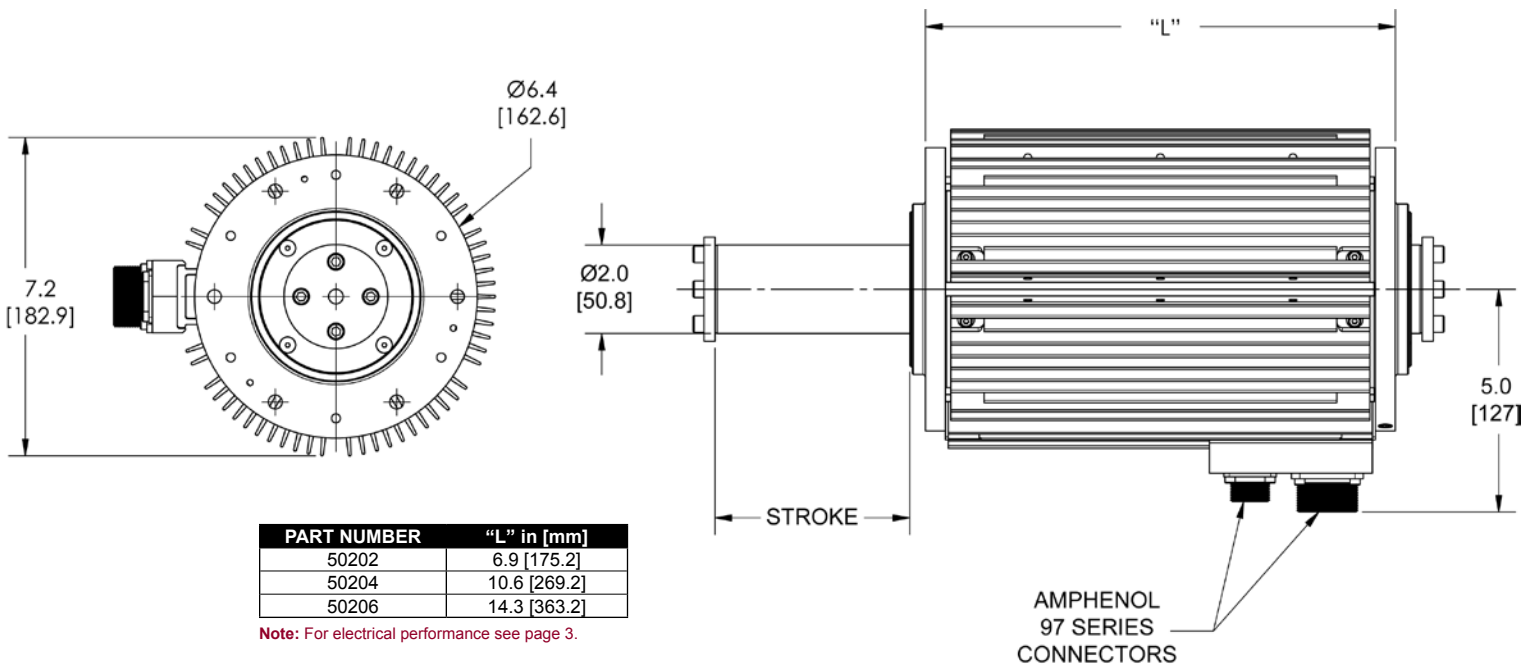

Dimensions are in inches [mm]

Note: For electrical performance see page 3.

## FORCE-VELOCITY CURVES - 220 VOLT MOTORS

40202

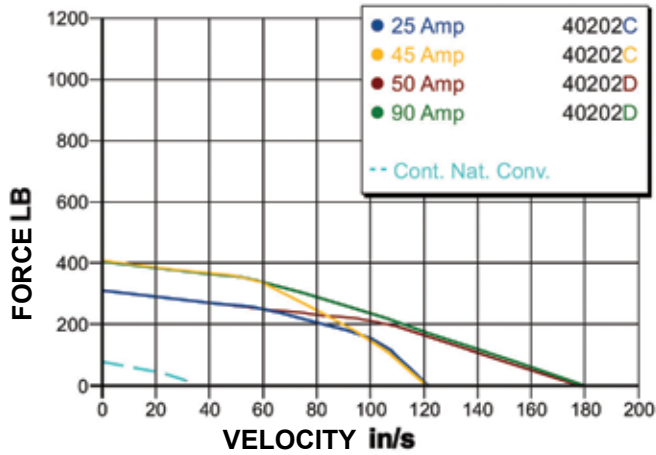

50202

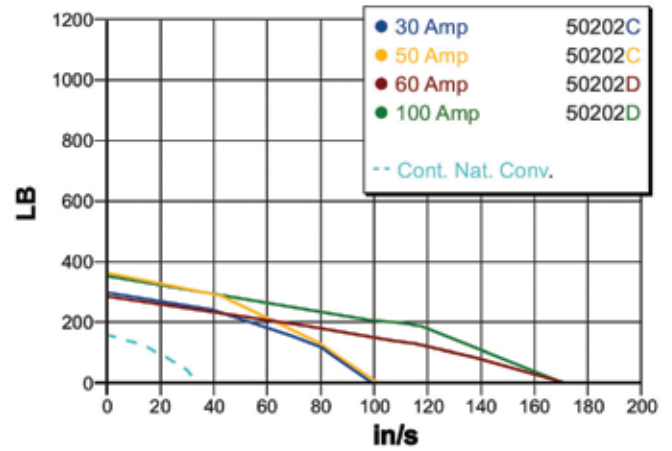

40204

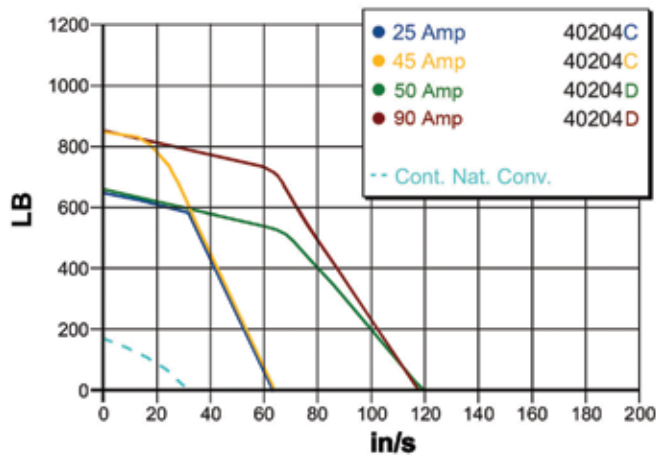

50204

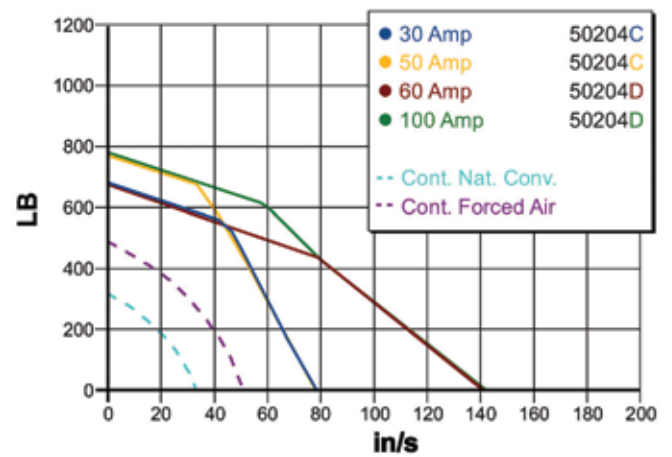

40206

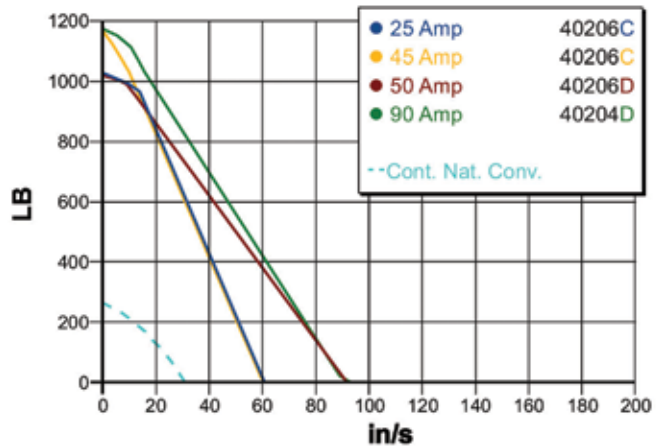

50206

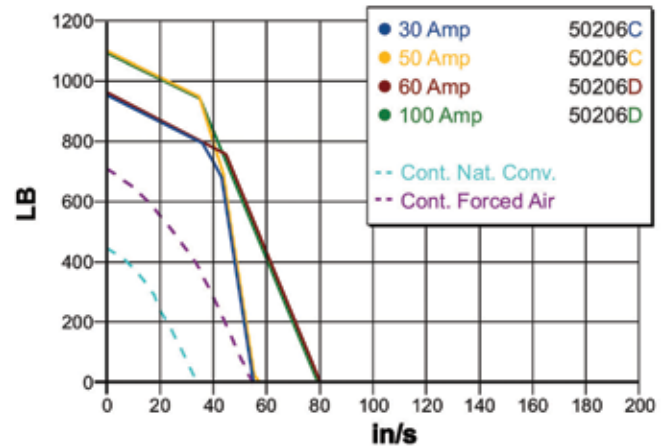

Performance obtained with Delta Tau PMAC2 controller and MTS Powerblock amplifier powered by 220 V 3-phase mains. Motors mounted to an aluminum plate. Allowed coil temperature rise is 75°C.

# Linear Motors

## FORCE-VELOCITY CURVES - 480 VOLT MOTORS

40202

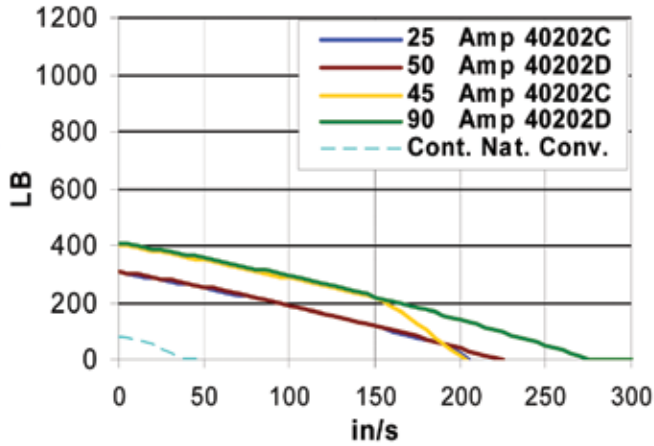

50202

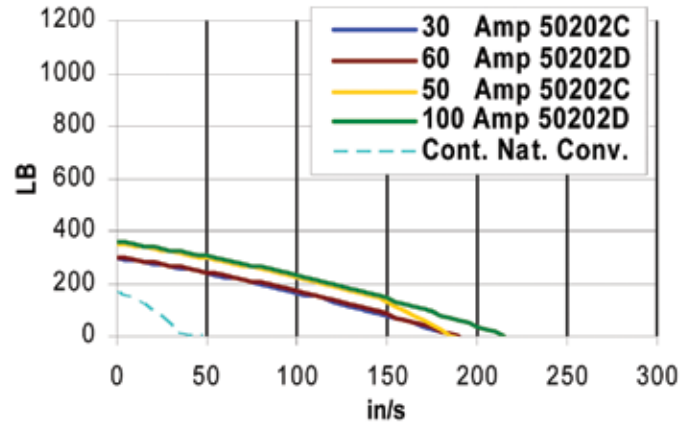

40204

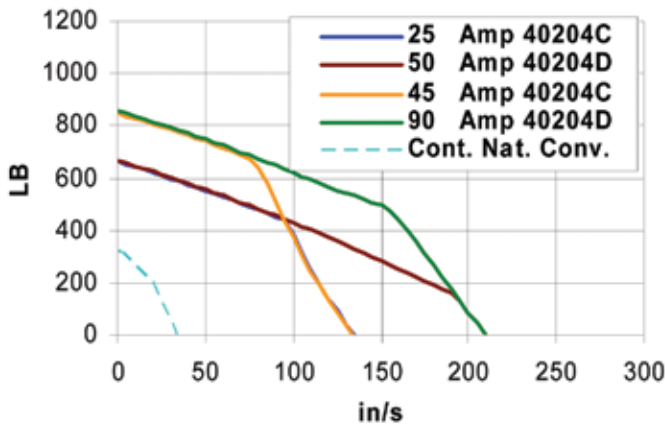

50204

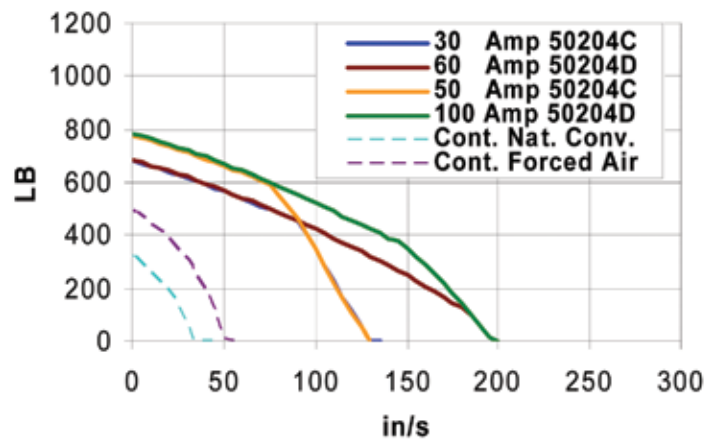

40206

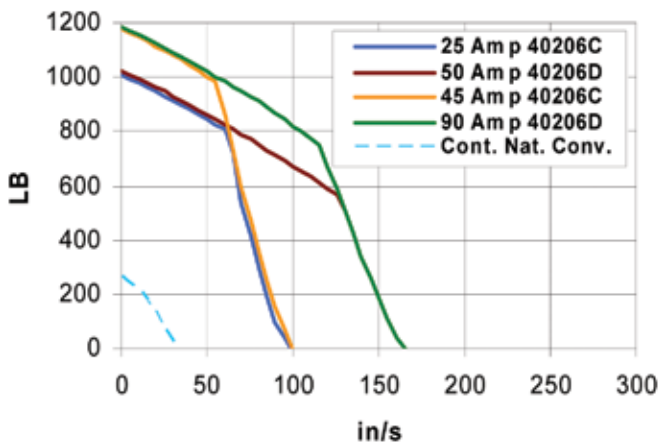

50206

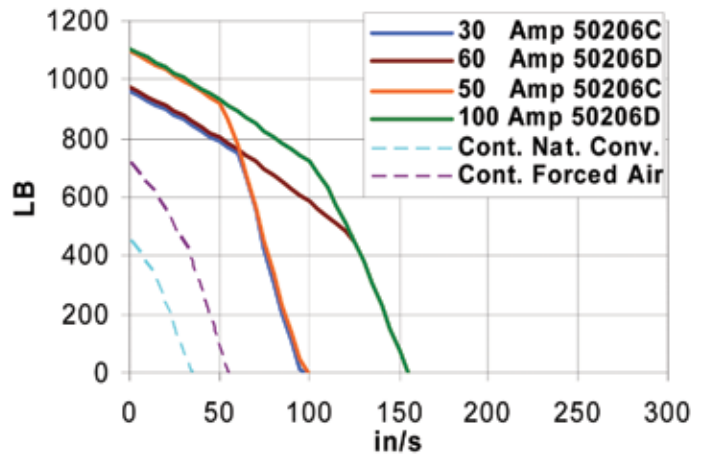

## SPECIFICATIONS - LIQUID COOLING

		4020					
Parameter	Units	2C	2D	4C	4D	6C	6D
Peak Force (1 sec)	lbf	410	410	850	850	1180	1180
	N	1824	1824	3781	3781	5249	5249
Peak Force (3 sec)	lbf	310	310	660	660	1020	1020
	N	1379	1379	2936	2936	4537	4537
Peak Current (1 sec)	A	45	90	45	90	45	90
Peak Current (3 sec)	A	25	50	25	50	25	50
Continuous Static Force (liquid cooled)	lbf	171	171	360	360	540	540
	N	761	761	1601	1601	2402	2402
Force Sensitivity (at 50% of 3 sec Peak Current)	lbf / A	13.7	6.8	27.7	13.8	44.1	22.0
	N / A	60.9	30.2	123.2	61.4	196.2	97.9
Back EMF Constant (ph-ph)	$V_{pk} / (\text{in} / \text{sec})$	2.09	1.05	4.08	2.04	6.44	3.22
	$V_{pk} / (\text{m} / \text{sec})$	82.3	41.3	160.6	80.3	253.5	126.8
DC Winding Resistance (ph-ph at 25° C)	ohms	2.9	0.7	5.9	1.5	8.8	2.2
Winding Inductance (ph-ph)	mH	20.5	5.1	40.3	10.1	60.5	15.1
Motor Constant	lbf / sqrt (watt)	9.2	9.2	13.2	13.2	17.1	17.1
	N / sqrt (watt)	40.9	40.9	58.7	58.7	76.1	76.1
Detent Force (peak)	lbf	10	10	10	10	10	10
	N	44	44	44	44	44	44
Thermal Resistance (liquid cooled)	°C / W	0.18	0.18	0.09	0.09	0.06	0.06
Maximum Stroke	inch	20	20	16	16	12	12
	m	0.508	0.508	0.406	0.406	0.304	0.304
Weight (add 0.62 lbm for each inch of stroke) (add 0.11 kg for each centimeter stroke)	lbm	32	32	45	45	59	59
	kg	14.51	14.51	20.41	20.41	26.76	26.76

Performance parameters and velocity curves are based on a 5°C coolant inlet temperature and a 2 GPM flow rate.

## DIMENSIONS - LIQUID COOLING

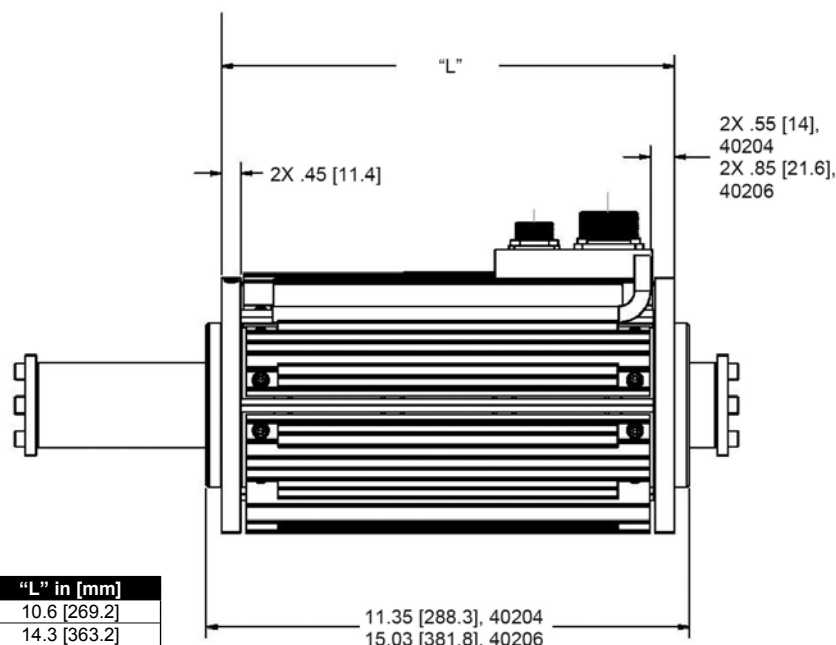
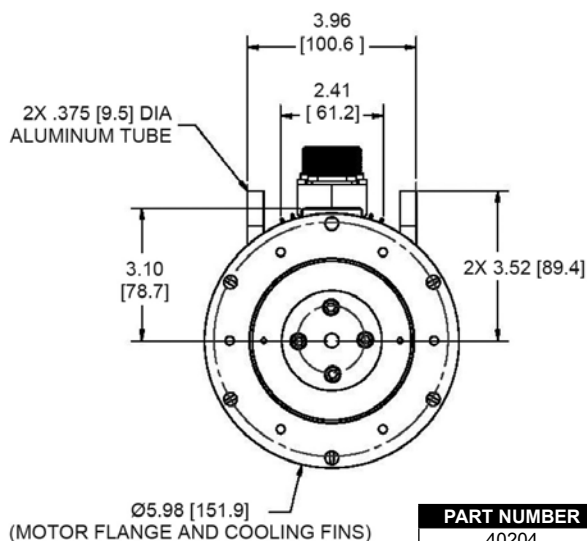

PART NUMBER	"L" in [mm]
40204	10.6 [269.2]
40206	14.3 [363.2]

Note: For electrical performance see above specs.

Dimensions are in inches [mm]

# Linear Motors

## FORCE-VELOCITY CURVES - LIQUID COOLING

### 40202

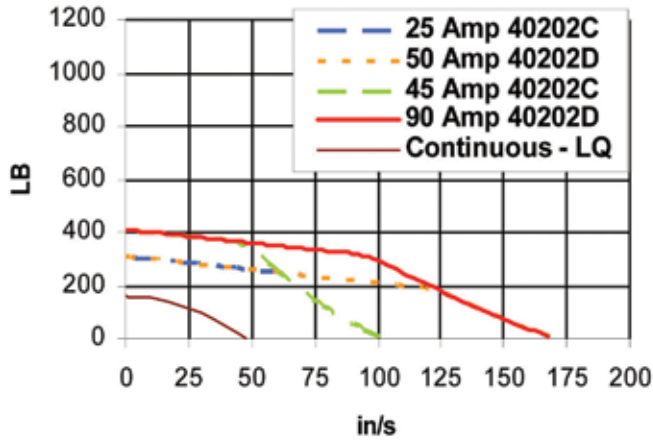

### 40204

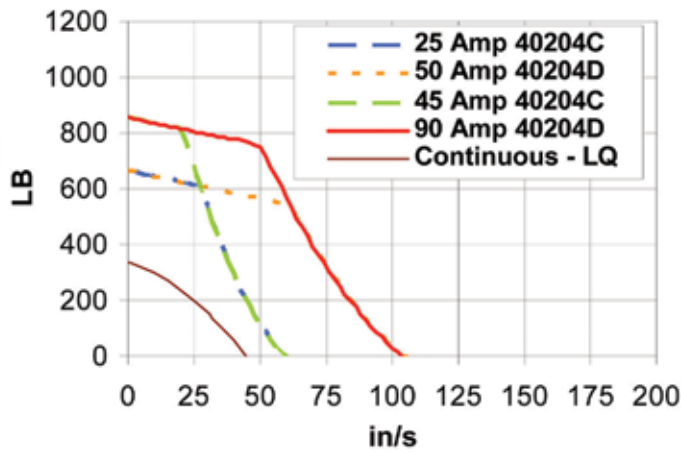

### 40206

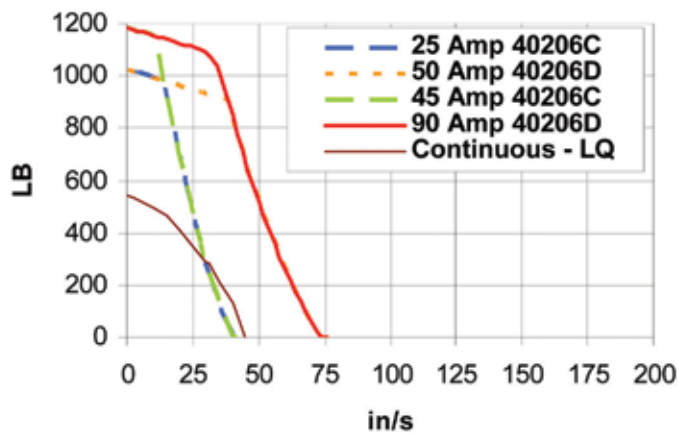

## TECHNOLOGY COMPARISON

Tubular linear servomotors offer an advantage in weight, size, maintenance costs, environmental considerations, precision, speed, control, programmability, reliability and noise. The patented technology offers the motion control industry an alternative to hydraulic, pneumatic and mechanical power sources for linear motion control. The linear motors are easy to install and integrate. Position and force are fully programmable and there is no backlash or fluid compressibility to compromise position accuracy.

The superior performance of Moog's linear servomotor results in improved profitability for a broad range of industrial motion control applications. The linear motor's high velocity enables manufacturers to increase throughput. At the same time, its high accuracy and consistent repeatability contribute greatly to improved product quality.



Its unique design incorporates the important features of a single moving part, integral bearings, compact size, and exceptionally high force per volume. These features deliver significant advantages, including cost savings, over not only traditional approaches including hydraulics, pneumatics, ball screws and other electromechanical systems, but also when compared to other linear motors.

With its single moving part and integral bearing system, the Moog linear motor is remarkably easy to install. Its simple design provides robust, reliable operation, and lowers life cycle costs. Its cylindrical configuration yields a highly efficient generation of force, enabling the motor to accelerate quickly to high velocities, even when handling heavy loads.

### The linear motor compared to the alternatives:

- Hydraulic systems are environmentally unfriendly, require an external power supply, and cannot match the programmability or reliability of the Moog motor.
- Mechanical devices such as ball screws, cams and pulleys have high maintenance requirements, limited programmability, and lack the velocity that can be achieved with the Moog motor.
- Pneumatic systems cannot achieve the accuracy, velocity, programmability or reliability of the Moog motor, and present environmental concerns similar to those of hydraulic systems.
- Competing linear motors are more costly, more difficult to integrate, and lack the Moog motor's integral bearing system. The external bearing system required for competing flat linear motors can cost as much as the motor alone.

Typical Linear Drive Comparison				
	Tubular Motors	Mechanical Drives	Hydraulics	Pneumatic
<b>Stiffness</b>	High	Medium	Medium	Low
<b>Friction</b>	Medium	Medium	High	High
<b>Temperature Range</b>	125° C max.	125° C max.	50° C max.	50° C max.
<b>Efficiency</b>	50%	40%	25%	25%
<b>Noise</b>	40 dB	80 dB	120 dB	120 dB
<b>Speed</b>	180 in / sec	10 in / sec	10 in / sec	20 in / sec
<b>Accuracy</b>	0.0005 in	0.001 in	0.01 in	0.1 in

For technical assistance please call: 610-328-4000.

# Linear Motors

## TYPICAL APPLICATIONS

### Conveyor

#### The Function

A fast-back conveyor moves dry goods along a production line, moving the product slowly in one direction and then reversing the conveyor back at high speed. The conveyor motion can be gentle in moving the product without shaking it too much.

This type of conveyor is used to move:

- Potato chips and seasoned foods – flavored potato chips or cereal, seasoned nuts
- Pharmaceuticals
- Rice and grains
- Small finished metal parts

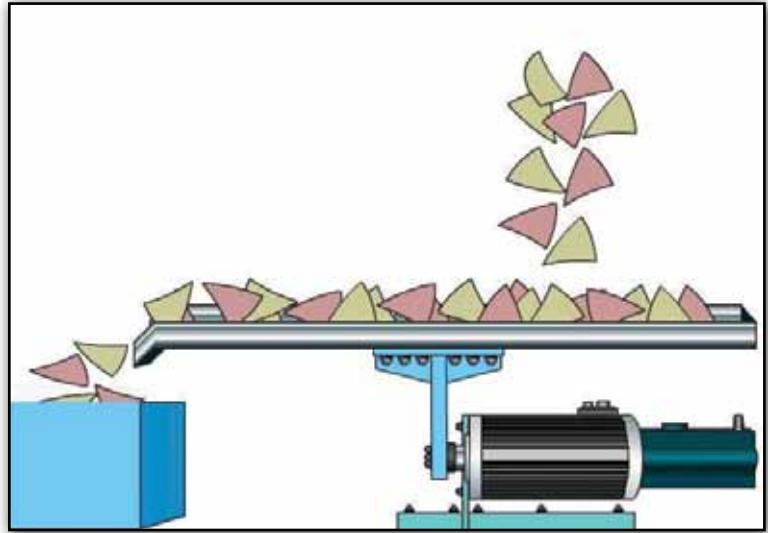

#### The Problem

Producing just the right type of movement without damaging the product is a complex engineering problem that usually requires intricate mechanical solutions.

#### The Solution

As part of a linear servo system, the Moog motor's programmability produces optimum motion for any product without the expense and high maintenance of complex mechanical systems. The Moog motor also is used with vibratory conveyors.

#### The Result

- Faster conveyance speed, even up slopes
- Easy modification of motion profile for products requiring different motion

Moog motors can even be electronically geared together to drive large conveyors – impractical to impossible for mechanical systems to accomplish.

## TYPICAL APPLICATIONS

### *Flying Die*

Plastic and metal forming industries rely on motors to manipulate, hold, and move product parts.

#### **The Function**

A flying die stamps or cuts a product while the product is in motion. The die is accelerated to match product speed, stamps or cuts the product and then returns to its original position. Flying dies are typically found in plastic and metal extruders, metal stamping and embossing.

#### **The Problem**

Synchronizing production line speed and die speeds at a precise location is an engineering challenge.

#### **The Solution**

The Moog linear motor automatically tracks and matches line speed.

#### **The Result**

- Faster throughput
- Reduced error and scrap rate
- Improved consistency

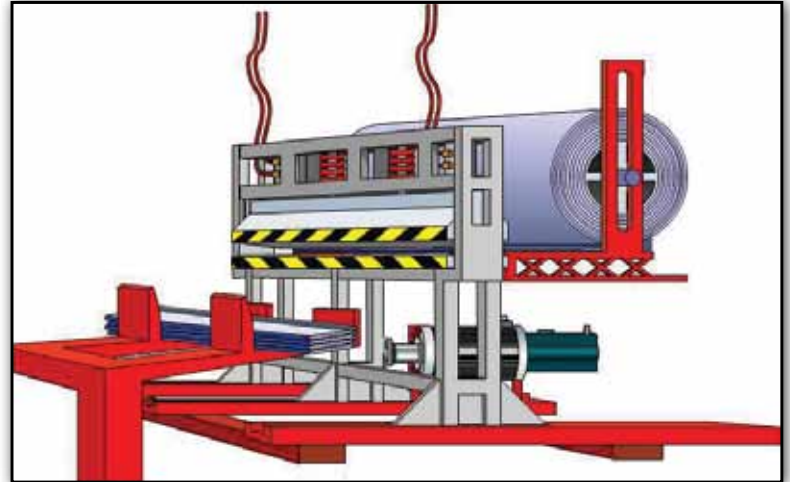

### *Destacker*

#### **The Function**

Many raw materials are supplied in large quantity bulk stacks. A destacker unstacks products consistently and precisely for production. Destackers are common in lamination production, and in manufacturing CDs, packaging materials, food products, etc.

#### **The Problem**

To avoid damaging the product, a destacker must make short, precise movements and stay perfectly in step with a pusher axis.

#### **The Solution**

A servo system with Moog motors is fully programmable for a precisely matching product thickness and finely tuned coordination between the axes.

#### **The Result**

- Faster line speeds
- Reduction of product damage

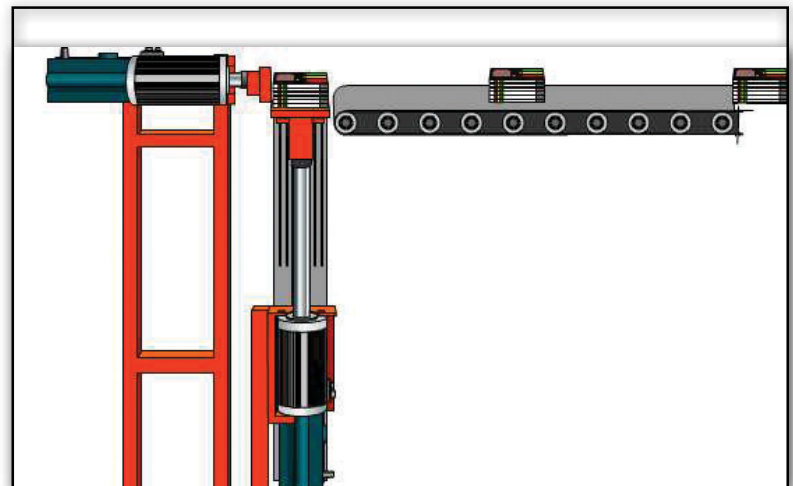

**Americas**

Moog Components Group  
1213 North Main Street  
Blacksburg, VA 24060  
United States

Tel: 540-552-3011  
Fax: 540-557-6400

**U.K. and Ireland**

Moog Components Group  
30 Suttons Business Park  
Reading, Berkshire RG6 1AW  
England

Tel: +44 (0) 118-966-6044  
Fax: +44 (0) 118-966-6524

**Europe**

Moog GmbH  
Hanns-Klemm-Strasse 28  
71034 Boeblingen  
Germany

Tel: +49 7031-622-0  
Fax: +49 7031-622-100

**Asia-Pacific**

Moog Japan Ltd.  
1-8-37 Nishi-Shindo  
Hiratsuka Kanagawa  
Japan 254-0019

Tel: +81 463-55-3615  
Fax: +81 463-54-4709

**MOOG**  
COMPONENTS GROUP

[www.moog.com/components](http://www.moog.com/components)

Email: [mcg@moog.com](mailto:mcg@moog.com)